

2024

PLEASURE NAVIGATION & RADIO-CONTROLLED RULEBOOK

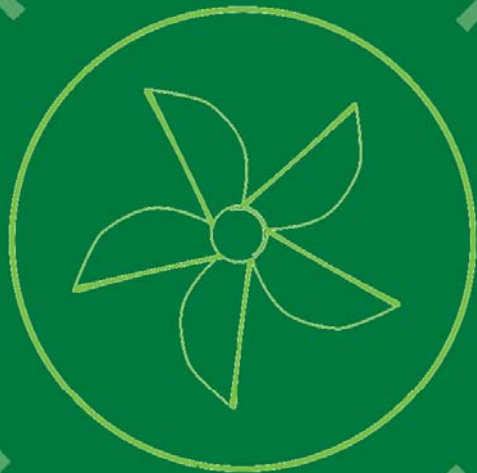



Endurance Group B - Promotion 150 (P)



**Francisco Javier
GARCIA PLAZUELO**
SPAIN



**Jose Manuel
PARDO HERRERA**
SPAIN

Endurance Group B - Boat Production 300 (B)



Bader ALDOUSARI
KUWAIT



Mohammed ALESSAEI
KUWAIT

Endurance Group B - Sport 450 (S)



Buby BERTELS
BELGIUM



Nico DE STOOP
BELGIUM



**Endurance - Group A -
HOCR F1**



Jeremy GIBSON
GREAT BRITAIN



Malachy BROWNE
GREAT BRITAIN



Bob MCCARTHY
GREAT BRITAIN



Mark POWER
GREAT BRITAIN

**Endurance - Group A -
HOCR F3**



Anthony SCACCIA
GREAT BRITAIN



Chris DOSSANTOS
GREAT BRITAIN

**Endurance - Group A -
HOCR Super Sport**



Marc Antoine POULLIER
FRANCE



Vincent CHRIST
FRANCE



PLEASURE NAVIGATION RULES 2024

PUBLISHED ON 21/12/23

UPDATE PUBLISHED ON 25/01/24:

- Inflatable Lifejackets not permitted,
Clarification (article 502.03.07.10, page 75)

UPDATE PUBLISHED ON 15/02/24:

- Modification of rules for S450 class (article 502.03.05, C, page 71)

TABLE OF CONTENTS

PLEASURE NAVIGATION RULES 2024	4
GROUP 100 UIM ADMINISTRATION	7
101 - UIM EVENT SANCTIONS AND THE SPORTS CALENDAR	7
104 - NON-APPROVED RACES	8
105 - TITLED INTERNATIONAL EVENTS	9
106 - INTERNATIONAL CHAMPIONSHIPS WORLD AND CONTINENTAL CUPS	9
107 - WORLD CHAMPIONSHIPS	10
108 - CONTINENTAL CHAMPIONSHIPS	10
109 - RACING LICENCES	12
GROUP 200 COMPETITION ORGANISATION	14
201 - EVENT AND RACE OFFICIALS	14
202 - ADVANCE-PROGRAMME	21
203 - ENTRIES	23
204 - EVENT INSTRUCTIONS	24
205 - SAFETY RULES	24
206 - INSURANCE	25
207 - MEDICAL EXAMINATION	25
208 - DISTINCTIVE MARKS	25
209 - ENVIRONMENTAL CARE IN RACE AREAS	26
210 - DISCLAIMER RULE	26
GROUP 300 SPORTS RULES	27
301 - REGULARITY COMPETITIONS	31
303 - POINT TO POINT COMPETITION	33
305 - HISTORICAL BOATS COMPETITION	40
306 - RALLY COMPETITION	46
307 - PROMOTIONAL MEETINGS	47
308 - ELECTRIC AND SOLAR PLEASURE CRAFT	47
GROUP 400 JURISDICTION	48
402 - JUDICIAL BODIES	48
403 - PROTEST PROCEDURES	49
404 - HEARING OF THE PROTEST	50
405 - THE APPEALS PROCEDURE	52
406 - PENALTIES	53
407 - PRIORITY OF THESE RULES	55
408- POWERBOAT PROTEST FORM	56
409 - ARBITRATION	57

GROUP 500 TECHNICAL RULES	58
501 - REGULARITY COMPETITIONS	61
502 - ENDURANCE COMPETITIONS	62
503 - POINT TO POINT COMPETITIONS	80
505 - HISTORICAL BOATS	85
506 - RULES FOR UIM MARATHON RACING	91
507 - RULES FOR UIM RIB RACES	99
GROUP 600 RECORDS AND PERFORMANCES	103
600 - RECORDS AND PERFORMANCES	103
601 - CLASSES ELIGIBLE FOR RECORDS	103
602 - DEFINITION OF UNITS	104
604 - BASES (THE COURSE)	105
605 - CALCULATION OF SPEED	106
606 - MARGIN REQUIRED	106
607 - MOTORS	106
608 - REQUEST TO ORGANISE	107
609 - OFFICIALS	107
610 - SPEED RECORDS	108
611 - DISTANCE RECORDS	108
612 - HOUR RECORDS	109
613 - WORLD COMPETITION RECORDS	110
614 - PERFORMANCE CERTIFICATES	110
615 - HOMOLOGATION OF RECORDS	111
616 - UIM RULES FOR LONG DISTANCE OFFSHORE MOTORBOAT WORLD SPEED RECORDS ..	112
GROUP 700 CUPS AND TROPHIES	122
701 - PAVILLON D'OR	122
702 - TROPHY MARIO AGUSTA	127
703 - TROPHY SANZ PINAL	129
RADIO CONTROLLED RULES	130
CODE OF ETHICS 2024	185
ANTI-DOPING RULES 2024	192
ENVIRONMENTAL CODE 2024	246

GROUP 100 UIM ADMINISTRATION

101 - UIM EVENT SANCTIONS AND THE SPORTS CALENDAR

101.01 - EVENT SANCTION REQUIREMENTS AND FEES

All international powerboating events must be sanctioned by the UIM and by the National Authority. An International Sanction is a written authorization which permits an organizing body to conduct an international event under the rules of the UIM.

Written approval by the UIM of the registration of an international event on the UIM annual calendar, subject to payment of a fee determined annually by the General Assembly, constitutes the granting of an International UIM Sanction for that event.

However, a national authority may accept 3 foreign drivers' maximum without having to pay international calendar fees. These drivers will not be scored in the final results.

Payment of these fees must be made within three months after the fixing of the international calendar. Permission to organise these meetings is only delivered by the UIM upon payment of these fees.

No permission is to be granted to National Authorities in arrears of payment.

All requests to organise an international championship must be sent to the UIM Secrétariat before the time set by the deadline in the rules.

The UIM Secretariat will not take into consideration the requests that do not offer all the information indicated in article 106.02 The commission will take into consideration the facilities for pilots, such as accommodation or trips, if any. The members of the commission will study the petitions and grant the championships as soon as possible. If there is only one request for a specific championship and this petition has the requirements, the members of the commission will give the championship immediately.

The organization of an event cannot be granted if the title, the classes, the locality and the date of the event are not given.

When compiling the Sports Calendar due attention is to be paid to the reports of the UIM Commissioner before granting the request to organise titled meetings.

The titled meetings have priority over all other meetings before the closing of the registrations for the sports calendar. However, when the sports calendar is finalized, all the motor boating meetings are on an equal footing.

101.02 - OTHER EVENTS

It is forbidden to organise National championships for series and classes which are in the programme of a titled event taking place the same day.

The calendar of National or local events is not to be submitted to the UIM The interested National Authorities take responsibility for their own calendar(s).

101.03 - DEADLINE DATES

1 March	Forwarding of requests for international titled events
1 April	Allotting of titled events to N.A.
September 10	Forwarding of dates and venues of titled events by the N.A.'s
	Forwarding of request for ordinary events, complete with dates and venues

CALENDAR MEETING

October	Drawing up of the international calendar
November 15	Publishing of the international calendar

101.04 - LATE REQUEST, CHANGE OF DATE AND CANCELLATION

TITLED EVENTS

Late request: A late request will be considered only if the title is still vacant or if the title or the event has been cancelled by the NATIONAL AUTHORITY to whom it was granted or by the UIM. If the title is granted, the organiser will pay the normal inscription fee.

Late forwarding of date or venue: the inscription fee will be raised by 50%.

Change of date: the inscription fee will be raised by 25 %.

The UIM give its assent to the new date. The request for a change of date must be received by the UIM Secretariat not less than 90 days before the calendar date. The new date will be fixed not less than 60 days after the date on which the request was received.

At less than 90 days before the calendar date, the date cannot be changed. The event will be cancelled or run as an ordinary event, but no part of the inscription fee will be refunded.

Cancellation: if the title or the event is cancelled 90 days or more before the calendar date, 50 % of the inscription fee will be refunded.

In a later cancellation there will be no refunding. A cancelled title will be treated like a title not yet requested.

NON TITLED EVENTS

Late request: the inscription fee will be raised by 25%.

Change of date: the inscription fee will be raised by 25%.

Cancellation: if the event is cancelled 30 days or more before the calendar date, 50% of the inscription fee will be refunded. In later cancellations there will be no refunding.

104 - NON-APPROVED RACES

All races not organised according to UIM rules are not to be recognized.

The same applies to motorboating events not approved by National Authorities.

A national race, or a race by "invitation" in which a foreign licensed driver is invited to take part must be entered on the UIM Calendar otherwise it becomes an unauthorised event, unless no more than 3 foreign drivers take part for the reason of training and without inclusion of their results/times in the results sheets. Remember that drivers having international licences, are only allowed to enter a meeting outside the country of their license, provided that their National Authority gives them written permission to do so.

104.01 - SPECIAL LICENSES

Without prejudice of the foregoing the Council may, on a yearly basis, issue a certain number of Special Licenses for riders and teams, allowing them to compete in races organized by non-UIM entities or under the aegis of entities other than the UIM and its National Authorities.

Such Special Licenses shall be granted to National Authorities, which shall issue them to the riders or teams applying accordingly.

Special Licenses can only be granted to the holders of UIM international licenses. Special Licenses shall be effective upon payment of the relevant fee, to be established by the UIM Council every year, and shall be valid for a maximum of three races in the year they have been issued.

Holders of the Special Licenses shall execute a discharge of liabilities vis-à-vis the UIM and the relevant National Authority. Such discharge of liabilities is condition precedent for the effectiveness of the Special License.

105 - TITLED INTERNATIONAL EVENTS

There are five categories of titled event(s):

- World Championship;
- World Cup;
- Continental Championship;
- Continental Cup;
- Grand Prix;

There can be one World Cup and Continental Cup event per class and per year, provided that a World or Continental Championship is not organised for the class in question.

There can be only one Grand Prix event per Country and per year, except when a World Championship series takes place in that Country

No meeting is allowed a title unless authorised to do so by the UIM who draw up the annual list in the official calendar.

No organiser can run more than 2 titled events (e.g., WC or CC) at any one meeting.

The UIM aims to protect titled meetings, the Council may refuse to sanction any meeting which takes place at the same time as a previously approved event. Such refusal is only notified at the specific request of the National Authority lodging a protest.

During prize presentations and ceremonies at UIM titled events, the UIM medals shall be presented by the highest ranking UIM representative(s) in attendance at the event.

106 - INTERNATIONAL CHAMPIONSHIPS WORLD AND CONTINENTAL CUPS

106.01- GENERAL RULES

World Championships are open to all UIM and American Power Boat Association (APBA) classes. There can be only one World Championship per class, per year.

For the Endurance classes, the UIM World Championship and/or Continental Championship can be composed of at least one event / Round per season.

The requests to organise these championships must be sent in due time. The Pleasure Navigation Commission will allocate the Championships. No exception is to be allowed to the preceding rule.

The UIM delivers a "champion's certificate", following requests made by the champions to their National Authorities and transmitted by that National Authority to the UIM Secretariat.

The cost of such certificate is fixed annually by the General Assembly and is to be paid by the National Authority to the UIM when the request is made.

A list of champions is issued annually. The UIM rules and those of the National Authority are applicable for any point not foreseen by these rules.

A person or a team can be proclaimed "Continental Champion" in category Pleasure Navigation only if at least three boats with competitors from two different nations have competed for the title.

A person or a team can be proclaimed "World Champion" in category Pleasure Navigation only if at least three boats with competitors from three different nations have competed for the title.

In the case of a World or Continental championship having more than one round, each round has to meet the minimum criteria for the championship to be considered a valid round.

A driver of non-European Nationality may be proclaimed European Champion provided he/she has had a European licence for more than two years. The same applies for other continents.

Immediately after the Championship, the National name of the Champion must be transmitted by fax to the UIM secretariat.

106.02 - WATER REGISTRATION

Permission to organise an International Meeting is granted ONLY if the race is run on a course recognised by the National Authority and documented as follows:

A plan to scale (1:1250...1:2500) showing accurately:

- a) The depth within a 5M distance either side of racing line;
- b) Position of ALL race buoys;
- c) Position of finish line;
- d) Position of jetty/beach (if applicable) or start line;
- e) Direction of competition;
- f) Other obstructions duly marked;
- g) Any other buoys not applicable to the competition;
- h) Position of control;
- i) Entry to water.. crane/slipway;
- j) Area for pits;
- k) Spectator barriers etc.;
- l) First aid facilities;
- m) An ALTERNATIVE competition course (if possible) only for use under "Force Majeure" conditions;
- n) Altitude of venues.

107 - WORLD CHAMPIONSHIPS

World Championships, allocated by the UIM Pleasure Navigation Commission are raced under the following rules as the Continental Championships.

108 - CONTINENTAL CHAMPIONSHIPS

108.01 - NUMBER OF CHAMPIONSHIPS

There can be one championship per year, per class, per continent (except where there is a series) only in classes approved by the Pleasure Navigation commission at the previous General Assembly of the UIM

108.02 - CONTINENTAL CHAMPIONSHIP EVENTS IN PLEASURE NAVIGATION

Continental Championships are open to all UIM Pleasure Navigation classes.

There can be only one Continental Championship per class, per year.

The Pleasure Navigation Commission will allocate the championships subject to any contract between the UIM and any promoter.

International classification is to apply for the teams of the National Authorities whose drivers take part in the championship. For the classification of the National Authority teams the result of those three drivers of each team having the highest number of points will be taken into consideration.

If fewer drivers are entered by National Authority teams or if only two or less drivers are classified, the points of that drivers are considered as those of the whole team. In case of a dead-heat, the classification will be made according to the best result of the team in question.

108.03 - PARTICIPATION

Drivers must be able to show their international licence, measurement certificate, and the homologation sheet for the boat and the motor(s).

The driver's entry is to be sent through his/her National Authority to the organising National Authority and to the organiser of the event at least 21 days before the beginning of the championship.

The composition of the National teams may be altered up to one hour before the start of the first heat.

108.04 - SELECTION HEATS

If the number of drivers entered is too large for all of them to start together the organising committee has to split the group of drivers into several groups.

Care should be taken to ensure that the drivers of each Nationality are evenly split into separate groups as far as possible. The committee will have each group run selection heats.

When heats are run, the classification is done as follows:

1 - 400 pts	11 - 22 pts
2 - 300 pts	12 - 17 pts
3 - 225 pts	13 - 13 pts
4 - 169 pts	14 - 9 pts
5 - 127 pts	15 - 7 pts
6 - 95 pts	16 - 5 pts
7 - 71 pts	17 - 4 pts
8 - 53 pts	18 - 3 pts
9 - 40 pts	19 - 2 pts
10 - 30 pts	20 - 1 pts

In case of a dead-heat, classification is decided by the best heat run by the drivers in question.

All classes must race separately even if they belong to the same series.

108.05 - GENERAL SPORT RULES

A separate classification is made for each class.

The champion receives a trophy given by the organising club.

Additional prizes may be awarded.

After the competition the boats of the first three classified drivers are inspected by the official measurer.

The title of champion is only granted after examination of the aforesaid boats.

109 - RACING LICENCES

109.01 - COMPULSORY LICENCE

No one can take part in a UIM event, establish or improve on a UIM record in international class boats, without being in possession of an international licence from their National Authority.

In order to obtain an international license or Superlicence, following disclaimer must be signed by the licence holder:

“The undersigned _____ licensed pilot (licence no. _____), participating to UIM sanctioned events, yields the media rights of any coverage by the promoter taken during the event, to the UIM for further use by press, radio or television. The right however remains the property of the undersigned.

In addition, I herewith agree and acknowledge the following:

U.I.M. is the governing rule making body of U.I.M. racing events which are responsibly organized by clubs, national authorities of UIM, contracted promoters or other organizers. These organizers do not act on behalf of the UIM and UIM is not responsible for any act or omission of such organizer and shall not be liable to the participant accordingly.

The U.I.M. sport and technical rules are intended to minimize risks but they cannot provide the highest possible safety standards at all times. Residual risks might remain.

Enforcement of the rules by UIM or other race officials and in particular but not limited to the technical scrutineering does not guarantee the safety of racing or the safety of the scrutineered boat. Scrutineering is not intended as a construction/ condition survey. The racing license issued by the National Authority or a super license issued by the UIM does not guarantee that a driver is physically able to race safely nor that he/she has sufficient experience or education.

Teams and drivers are solely responsible for their own safety including but not limited to their physical and educational ability to race in the relevant class, the safety of their boats and other gear and the safety of their racing activity. This responsibility includes racing with prudence and taking technical measures which are not mandatory in the rules but deemed necessary.

UIM shall not be liable for any damage, injury or death due to inadequate rules, breach of existing rules by participants or failure to enforce rules by the race officials.”

109.02 - REGISTRATION

The National Authority establishes each year a list of people to whom international licences have been delivered and this must be sent to the UIM Secretariat.

The list must include:

- The name and surname, the address and email, the class(es) for International Licence only and the Anti-doping consent form of UIM Anti-doping Rules duly signed per acceptance.

These lists may be sent to other National Authorities. Licence numbers are given annually by the National Authority to the owners and drivers entered on the list. Any person wishing to obtain a licence must apply to the National Authority through his/her club. The licence is granted by the National Authority and is marked “International” as decided by the National Authority. Licence holders must have a current UIM rulebook. For all international endurance races, titled or not titled, only one current UIM rulebook will be required per boat, not per driver.

Any National Authority has the right to deliver licences to:

- Its nationals,
- Nationals of another Country affiliated to the UIM only with the agreement of the National Authority of that nation.

With the approval of the UIM a National Authority may also deliver licences to persons belonging to a Country which is not yet affiliated to the Union.

Drivers are only permitted to hold licences from one National Authority.

A National Authority may refuse to give a licence without having to state the reason. Notification of this is sent to all affiliated clubs and to the UIM.

109.03 - VALIDITY OF LICENCES

Licences are valid from the 1st of January until the 31st of December each year, unless local circumstances require other date. In any case validity should always be shown on the licence itself and must be for one year.

A licence is valid in any Country affiliated to the UIM and entitles the holder to enter or drive in a boat in all competitions organised in any affiliated Country, provided he/she complies with what is stated in the UIM rules.

However, when entering any event held under special rules, the licence holder must abide by these rules.

109.04 - COST OF LICENCE

The cost of the yearly licence is to be fixed by the National Authority.

109.05 - EXAMINATION OF LICENCES

At any meeting, the holder must produce his/her licence at the request of any official of the meeting.

109.06 - PSEUDONYM

The use of a pseudonym must be requested from the National Authority and the National Authority marks the pseudonym on the licence.

A licence holder, as long as he/she is listed under a pseudonym, may not take part in any sports event under any other Name.

Changing a pseudonym is subject to the same formalities as the adoption of it.

Anyone who has chosen a pseudonym may not return to his/her actual name until the National Authority has agreed and has delivered a new licence.

GROUP 200 COMPETITION ORGANISATION

200.01 - GENERALITIES

The following bodies have the right to organise any Pleasure Navigation motor-boating event: National Authorities and their Affiliated Clubs, Corresponding members of the UIM, UIM contracted promoters (with the agreement of the National Authority).

All events have to be sanctioned by the National Authority.

Affiliation to the National Authority implies their acceptance of the National rules and those of the UIM

A club, a club member or driver who is suspended, is not allowed to take part in any sporting event in his/her Country or in any other Country neither as a driver nor as an official, as long as the suspension lasts.

A member or a driver who takes part in any event in a foreign Country affiliated to the UIM is, ipso facto, under the jurisdiction of the National Authority of that Country and needs to abide by the rules of the National Authority of that country.

All clubs, organisers, officials and drivers are obliged to know the general rules of the UIM as well as the rules related to competitions or series (local, national or international).

Two updated copies of the present rulebook must be available at every race.

All events organised by the National Authorities or their clubs are subject to the UIM rules. All advance programmes and race instructions must mention this.

The general rules and the rules related to records are applicable to all the international series.

200.02 - INTERPRETATION OF THE RULES

In all cases not foreseen by the International rules, the National Authority, a race committee, race jury or an appeal board, is to judge bearing in mind the intention of the disputed rules.

The English text is the official one. In case of disagreement on the interpretation of these rules, the English text prevails.

201 - EVENT AND RACE OFFICIALS

201.01 - LOCAL EVENT COMMITTEE, RACE COMMITTEE, JURY

All competitions are under control of a local organising body approved by and affiliated to the National Authority of the country in which the event is run. The organizing body nominates:

- A local Event Committee which organises the general and administrative aspects of the **event**.
- A Race Committee which organises and supervises the actual competition, determines any special event rules, determines the race course and decides whether competitors are eligible or not.

The Race Committee is composed with following race officials:

- the Officer Of the Day (O.O.D.),
- the Safety officer or Deputy Officer Of the day (D.O.O.D.),
- the Medical Officer (Rescue coordinator in charge of the rescue team),
- the Race Secretary,
- the Technical Officers (scrutineers in charge of all technical inspections and technical verification),
- the Starter
- the Safety Coordination Officer
- the Race Course Officials (officials in charge of the layout of the marks/buoys of the race course)
- the Timekeepers

- the Buoy & Course Marshalls,
- the Communication Officials
- the Dry and Wet pit Officials

The Race Committee must inspect and verify all entrants' documents required prior to competition through its various officials. Measurement Certificates, licences or superlicences, etc., and decides whether competitors are eligible or not.

The technical officials verify whether or not the boats and engines are conform to the rules.

■ A Jury, (see rule 402.01.1)

The names of the members are to be printed in the advance programme and in the race instructions. It is recommended that the Jury consists of minimum three nationalities. The jury decides on any dispute or protest submitted to them.

The decisions of the Race Committee and the Jury must be based upon the UIM rules, but as no rules can be devised capable of covering every case, the Race Committee and the Jury should discourage all attempts to win by means other than fair racing, superior speed and skill.

The decisions of the Race Committee and the Jury must be based upon the UIM rules, but as no rules can be devised capable of covering every case, the Race Committee and the Jury should discourage all attempts to win by means other than fair racing, superior speed and skill.

No officer, nor member of the Jury, nor member of a National or International Committee or Commission, is allowed to intervene in the judgement of a problem in which he/she is involved himself or in which he/she is an interested party.

201.02 - INTERNATIONAL LISTS

- Lists of International Officers Of the Day (I.O.O.D.) and of International Jury Chairman (I.J.C.) are deposited with the Secretariat of the UIM
- Every year, each National Authority has to transmit to the Secretariat its new list of I.O.O.D. and I.J.C. or the confirmation of the previous year's one not later than September 30th.
- Each National Authority may propose for enrolment in the list of International Officer Of the Day and I.J.C. only those Officers that have been regularly qualified by the said National Authority.
- Requirements for the enrolment of a candidate:
 - a) giving a personal record (containing personal data, address, e-mail address and telephone numbers).
 - b) have the ability to speak and understand the English language.
 - c) have no less than a three years' experience in the position applied for.
- Only people enrolled in the UIM lists are allowed to be appointed to the positions mentioned above and therefore to be appointed by their National Authority to perform such duties in international events valid for UIM titles.

201.03 - DUTIES OF THE RACE OFFICIALS

The Officials shall perform only the duties with which they are entrusted.

201.04 - THE OFFICER OF THE DAY (O.O.D)

The Officer Of the Day must supervise and manage the organisation of the races on behalf of the local organising body or club. He/she supervises and is leading the drivers' briefings, maintains order on the race course, ascertains that all services work properly, ensures that all correspond to the rules and observe the Racing Rules according to the Programme. He/she gathers and analyses the written reports from the Officers and Timekeepers and all any other documents required to enable the results to be compiled. He/she verifies any decision to stop or curtail a race. He/she is not allowed to be a member of the Jury. The O.O.D. has a complete overview of what is happening in and around the race and should make decisions necessary for safety and smooth running of the races.

All other race officials must report to the Officer of the Day.

For any World and Continental Championship events, the Officer of the Day must be a UIM approved person. To qualify, he/she must meet the following minimum standards:

- a) have had previous experience in controlling at least 3 important races.
- b) have a good knowledge of the UIM Pleasure Navigation rules
- c) have the ability to speak and understand the English language
- d) be nominated by his/her National Authority for UIM International Officer of the Day as per UIM rules

A list of approved persons is held by the UIM secretariat and reviewed each year by the Pleasure Navigation Commission (considering also any reports from UIM Commissioners).

Nominations for international O.O.D. approval shall be sent to the UIM by the nominee's National Authority, accompanied by details of his/her qualifications and previous experience (CV).

National Authorities must keep a list of their approved persons up to date and notify the UIM accordingly of any changes.

If an organising National Authority has not a local qualified nominee for acting as O.O.D. for an international event, then the UIM will together with the President of the Pleasure Navigation Commission appoint another O.O.D. for that event and will choose this O.O.D. out of the list of approved persons from other nations.

201.05 - THE DEPUTY OFFICER OF THE DAY (D.O.O.D.) OR SAFETY OFFICER

The Deputy Officer Of the day co-ordinates together with the Officer Of the day the safety services on shore (fire) as well as on the water (boats, people on board, material) as in the air. When necessary, he/she deputises for the Officer Of the day.

The Safety Officer is responsible for organizing a safe race course and will coordinate with the Race Course officials, the people responsible for laying the race buoys of the race course.

201.06 - THE MEDICAL OFFICER AND RESCUE OFFICIALS

The Medical Officer is responsible for the medical organisation in the race area.

In agreement with the Officer Of the Day, the Safety Officer (D.O.O.D) and the Safety Coordination Officer, he/she controls the relevant emergency responses.

The medical and Rescue officials are responsible for all first aid and rescue procedures. The rescue personnel must be fully trained in emergency accident procedures with emphasis on resuscitation, spinal type injury care and trauma treatment. They must have facilities available for emergency treatment and facilities for fast transportation of seriously injured persons to the nearest hospital.

The Medical Officer must ensure that adequate rescue boats and rescue helicopter(s) when required, are available with trained personnel at strategic points of the race course and must ensure that they are equipped for any rescue eventuality. At the scene of an accident, a qualified doctor can take command of emergency services and actions.

201.07 - THE RACE SECRETARY

The Race Secretary is responsible on behalf of the Officer Of the Day and the Deputy Officer of the Day, for the practical side of the event and organisation and must satisfy himself or herself that the various race officials know their respective duties and that they have all the necessary documents and equipment required for these duties. He/She must collect all documents established during the event (race bulletins, results, protests, protest decisions, etc.)

The Race Secretary is also working closely with the UIM Commissioner and must take care that the UIM Commissioner will get all necessary documents and information required at the event.

201.08 - THE TECHNICAL OFFICERS

The technical officers or scrutineers are responsible for ensuring that the physical dimensions of a boat, its equipment and engines comply with the relevant class regulations.

The Technical Officers ensure that all competitors are in possession of their Measurement Certificates and homologation sheets (or production verification) available for inspection and shall verify that the hull and engine(s) are conform to the measurement certificate, homologation sheets and the rules.

They check and control safety devices for boats and drivers as provided for in the rules. Scrutineers should be specifically delegated for this duty and have experience.

Special attention must be paid to the engine and fuel shut-off devices (where applicable), driver protection and safety devices, fire protection equipment and they must see that the competition number is clearly visible and conform with the rules.

After the races, the technical officers must carry out all necessary post-race scrutineering checks.

They must report any infringements found in writing to the Officer of the Day at the end of post-race scrutineering.

When no infringements found, they must advise the O.O.D immediately at the end of post-race scrutineering.

The technical officers shall use a checklist for their pre- and post-race verifications. It is not permitted to disqualify any participant for reasons that were visible during pre-race inspection.

201.09 - THE STARTER

The starter is responsible for the verification of the start boat which is made available for the races. He/she shall check if the start boat is adapted to the needs (e.g., check the speed which the startboat can attain) and shall check if all necessary equipment for the start procedure (flags, radios, VHF, etc) is on board and shall check if radio communication is functioning properly with race control and drivers.

The starter is responsible for the safe and orderly execution of the race start.

The starter must follow the start procedure as stipulated in the Race Instructions and communicated during the drivers' briefings. The starter must be on the start boat and signals the start when he /she feels it is correct to do so. He/she is in communication with Race Control and must await final ok from Race Control to start the race.

201.10 - THE SAFETY COORDINATION OFFICER

The Safety Coordination Officer organizes and manages the safety services on shore (fire, ambulance, security, equipment) as well in the dry pits, wet pits as on the water, in conjunction with the O.O.D.

He/she is working closely with the Medical Officer or Rescue Team coordinator.

He/she is in communication with buoy marshalls, rescue boats, tow boats and rescue team personnel.

201.11 - THE RACE COURSE OFFICIALS

The Race Course officials are in charge of the layout of the marks/buoys of the race course and report to the Safety Officer and the O.O.D. or race director. The local organizing club shall provide an adequate boat for this duty, and shall provide the necessary material as buoys, cords, weights and anchors, if not provided by a promoter for a specific class.

201.12 - THE TIMEKEEPERS

For international events there must be at least two timekeepers.

Timekeepers must use reliable synchronized timing apparatus, which has been certified.

They must keep detailed records of the timing of each boat and hand these to the Race Secretary at the completion of the race.

The Timekeepers will:

- Calculate on completion the elapsed time of each driver.
- Establish the finishing order after having made all necessary calculations and establish the lap times, maximum speeds (if required) and average speeds (if required).
- Hand over the provisional results to the Officer Of the Day and the Race Secretary.

The timekeepers are responsible for recording the start time, all lap times and the finish time and finish order of a race. They must be located at a position where they have clear un-obstructed view of the start and finish lines. In some races they might be required to carry out lap timing at turning points other than just the start and finish lines.

201.13 - THE BUOY AND COURSE MARSHALLS

The buoy and course marshalls must ensure that the drivers and boats conform to the racing rules. At the end of the race, they draw up and sign a statement certifying that all drivers' conduct during the race and at the turn buoys was according to the rules and race instructions.

This statement is handed to the Officer Of the Day who will enforce the rules when in case of infringements. Buoy officials are allowed to be in boats.

The buoy and course marshalls monitoring the turning marks and course of the race boats must have a clear un-obstructed view.

201.14 - THE COMMUNICATION OFFICIALS

The Communication officials are responsible for maintaining radio or other alternative means of communication between all key race officials. Communication officials are operating from the race control headquarters. Communication is to be made with competitors in the race boats, race officials, rescue boats, tow boats, local official authorities, etc.

201.15 - THE DRY PIT AND WET PIT OFFICIALS

The dry and wet pit officials are responsible for the organization, management and operation of all activities involved with the dry and wet pits and cranes.

They will organize all dry and wet pit facilities to meet the needs of the teams and the needs of the event- and race officials. The dry pit and wet pit officials shall report to the O.O.D. and cooperate with the Safety Officer.

They maintain order in the wet and dry pits. They are responsible for the parking of the trucks, parking of the trailers with boats, fuelling of the boats (if in the pit area), the launching and retrieving of boats and for all safety procedures within the pit areas including fire safety.

201.16 - UIM COMMISSIONERS

The presence of both a Sports Commissioner and a Technical Commissioner of the UIM is required at any International titled meeting. His/her role is to ensure a fair and safe race competition according to the UIM regulations and rules. He/she ensures that UIM rules and regulations are adhered to.

1. Tasks and function of the UIM Sports Commissioner

The UIM Sports Commissioner represents the UIM and has the following duties:

- a) He/she assists the local organizer and more particularly the Officer of the Day (O.O.D.) and Assistant O.O.D/Safety Officer.
- b) He/she is a voting member of the Jury.
- c) He/she approves last minute amendments to the advance programme

- d) Before the first drivers' briefing, he/she shall check with the race secretary that all paperwork has been done in line with UIM rules and regulations.
- each competitor is in possession of an international licence issued by his/her NA and authorization from his/her N.A. to race abroad
 - a turtle test certificate may be required in case of closed cockpit boats
 - signing of the drivers' declaration or waiver regarding responsibility
 - acknowledgement and agreement regarding anti-doping rules (Appendix 3 in UIM Anti-Doping Rules)
 - insurance coverage
- e) Before the practice sessions and first drivers' briefing, he/she must check with the O.O.D. and Safety Officer the safety plan and check if the race course is safe and if all safety requirements are met.
- the number and placement of buoys for the race course
 - the depth of the race course
 - the length of the race course, also taking into account the number of participants
 - the length of the start run to the first turn buoy
 - the number and placement of rescue boats
 - the number and placement of tow boats
 - the presence of an ambulance close to the wet pits
 - the radio communication channels
 - the start procedure for the races
 - a plan covering bad water or bad weather conditions

The UIM Commissioner is entitled to request that an event is suspended if safety conditions are not satisfactory. The UIM Commissioner is entitled, in conjunction with the O.O.D., to take action with the race organizers if required safety standards are not met.

- f) The UIM Sports Commissioner must be present at all official drivers' briefings. He/she shall be presented to the teams by the O.O.D. at the first drivers' briefing together with the jury members.
- g) He/she ensures that UIM rules and regulations are adhered to.
- h) He/she assists the local organizers and is present from morning to evening in the race areas (dry pit, wet pit, race administration, race control) during all event days.
- i) He/she takes part in important decision-making during the races with the O.O.D. and Safety Officer. The UIM Sports Commissioner should go with the O.O.D. to Race Control to have a good overview on the race, to follow the race control communications with the competitors and to be able to advise the O.O.D. and Safety Officer in urgent decision making or in emergency decisions.
- j) He/she also takes part in urgent decision making with the O.O.D. and the organizing local promoter in matters related to the overall organization.
- k) He/she is entitled to take action with the race committee if safety conditions are not met.
- l) The UIM Sports Commissioner, together with the O.O.D., signs and approves the provisional and official results issued by the official timekeepers, before these are posted on the notice board at race administration office.
- m) The UIM Sports Commissioner can handle misconduct together with the O.O.D. and give sanctions to a driver (UIM yellow card).
- n) In case of a yellow card, he/she reports this to the UIM in his/her report.
- o) The UIM Sports Commissioner is also involved by the local organizers in the prize giving ceremony, handing out UIM medals for titled events, unless a higher positioned UIM representative is present.
- p) The UIM Sports Commissioner is entitled to request that alcohol and drug tests be taken at the event, in particular if he/she thinks a competitor may have infringed the anti-doping rules and regulations.
- q) After the event, the UIM Commissioner writes a report by using the official form, as foreseen and drawn up by the relevant commission, to be sent by e-mail to the UIM secretariat within 10 days after the event. He/she shall include with his/her report the race map, the entry list, the results and any other documents that had importance for the event.
- The UIM Commissioner report is to be considered as confidential matter and cannot be used for aims other than UIM's internal purposes, may not be communicated to the press or otherwise disclosed for any purpose whatsoever.

The UIM Office shall send a copy of the report to the President and members of the Commission in charge of the relevant race category and to the National Authority of the organizer.

Should any Commissioner fail to obtain all necessary data and results for transmission to the UIM Office, he/she shall note it in his/her report and urge the organizers to send all required documents to the Secretariat of the UIM without delay

2. Tasks and function of the UIM Technical Commissioner

In case there is no UIM Technical Commissioner at the race, these tasks are taken by UIM Sports Commissioner.

The UIM Technical Commissioner is the representative from the UIM and his/her duties are very diverse:

a. He/she assists the local organizer and more particularly the Technical Officer and take part in important decisions in technical matters

b. Before the first drivers' briefing, he/she shall check with the race secretary that all measurement Certificates, log books cockpit documentation and homologations sheets for the boats and the engines are verified to confirm UIM rules and regulations by the technical scrutineers on at the event

c. He/she performs also inspections of the facilities and inspects the dry and the wet pits, this at any time before and during the event and observes if all security aspects on land are made as foreseen by the UIM rules as regards to

- placement of fire extinguishers
- presence of the ambulance and personnel
- placement of garbage/trash containers
- placement of containers for waste of oil
- safety of fueling area + presence of absorbing mats

d. He/she observes and verifies the application of the UIM Environmental Code as he/she has to take care that ground and water are protected. He/she will handle the environmental observations on titled events and include his/her observations in his/her report afterwards: he/she shall

- observe and verify the application of the Environmental Code
- inform the UIM sports commissioner and O.O.D. of any violation of the Environmental Code in order to pronounce sanctions relative to the infraction
- identify areas of good practice and make recommendations or proposals of modification to the Environmental Code

e. He/she ensures that UIM rules and regulations are adhered to and he/she is present in all pre- and postrace scrutineering and reports any finding to the UIM sport commissioner.

f. He/she assists the local organizers and he/she must be present in the race areas (dry pit, wet pit, race administration, race control) during all event days.

g. He/she handles the UIM ECUs

h. The legality of the fuel is solely under the judgement of the UIM Technical Commissioner, based on all tests made available to him/her.

i. He/she assists in reporting of incidents to UIM and in measurement certificates and log books.

j. After the event, the UIM Technical Commissioner must write a report by using the official form, as foreseen and drawn up by the relevant commission, and must send his/her report by e-mail to the UIM secretariat within 10 days after the event. He/she must include with his/her report the results of all post-race scrutineering and any damage to boat or equipment during the races.

k. The report from a UIM Technical Commissioner shall be attached to the UIM Sport Commissioner report by the UIM Office.

j. A copy of the report shall be sent by e-mail by the UIM office to the president and the members of the commission of the relevant race category and to the National Authority of the organizer. UIM Commissioners shall consider the races with the same standards, completed with own opinions.

3. Appointment of UIM Commissioners

UIM Commissioners are appointed by the Secretary General in coordination/ consultation with the chairperson of the relevant Commission/Committee in charge of the Boat Class involved from the listings provided by the National Authorities, and/or the list drawn up by the Commission in charge of the discipline.

An UIM Commissioner cannot be appointed to an event organized by his/her own National Authority, unless by reason of force majeure.

4. Commissioner's Accommodation and reimbursement of travel expenses

The National Authority of the event must remind the local organizers of their obligations:

- a) to accommodate the UIM Commissioner in a good hotel for the whole duration of the event and as long as is required for the accomplishment of his/her mission at the expense of the organisers.
- b) to bear the travel expenses from the town of residence of the Commissioner to the place where the event takes place (return ticket, economy class). If the UIM Commissioner has bought his/her air/train ticket, said costs are to be reimbursed in cash during the event. The Commissioner may charge an indemnity of **0,50** Euro per km in case travel by car is involved, as well as costs for parking, if applicable.
- c) to provide daily meals to the UIM Commissioner or to offer a per diem (a fix amount per event day) for food and drinks. If the organisers do not offer daily meals and local transportation to the Commissioner, they must be paid actual costs or a minimum of 60 euro per day.
- d) to provide local transportation for the whole duration of the event, if necessary.

202 - ADVANCE-PROGRAMME

202.01 – FORWARDING DATE

60 days before any international race, the organising committee must forward the advance programme to the UIM Secretariat.

The relevant Commissions and Committees will examine it for completeness and correctness within 15 days so it can subsequently be published on the UIM website.

Any such recommendation should be accomplished at least two weeks prior to the event.

The UIM representative will ensure on-site that the circuit matches the plan.

Should rule 202.01 not be complied with, the Council has the right to request the Pleasure Navigation Commission to apply a suitable penalty against international events during the following year.

Should the Advance Programme fail to be forwarded within the terms provided for, the championship will be granted to another organiser from the same National Authority.

Should the 60 days delay not be complied with, the calendar fee will be double.

The above advance-programme must be written in the language of the organising Country and in English and must contain the following information written in the same order point by point:

1. The name and the address of the organiser.
2. The series and classes of boats catered for.
3. The competition or competitions which will be run.
4. The venue and the date of the competitions.
5. The course of each competition and plan drawn to scale showing all details as per rule "106.02 WATER REGISTRATION".
6. The competitions are held under the UIM rules.
7. The special conditions which in accordance with the UIM rules may be added or modified.
8. Time limit and place to which entries must be sent, and whether written, by fax or by hand.
9. The amount of the entrance fee, except for Continental or World Championships for which there is no fee.
10. All information regarding the prizes for each race.
11. Where and when the entry forms, programmes and competition instructions can be obtained from the Organising Committee.
12. Transport facilities and concessions.
13. Terms and conditions of a mandatory insurance for personal and material damage to third parties and competitors, with details about:
 - The minimum limit of coverage's required.
 - Kind of risks to be covered by the insurance.
 - Whether insurances from other National Authorities are authorised and if they are, in which language they must be drawn up;
 - The amount of insurance fees to be paid on the spot (80 Euro maximum).
14. Minimum age of competitors.
15. Times for practice per class and the interval between the heats.
16. Full instructions regarding noise regulations.
17. Date and times for scrutineering.
18. Should no publicity be allowed during a competition, this is to be mentioned in the Advance Programme.
19. The time limits for late starters and finishers.
20. No modifications are to be made to any particular rule after the Advance Programme is posted except if decided by the Event Committee and approved by the Jury and for cases of force majeure only. The modifications must be communicated, by written means, to the officials and participants, 1 hour before the first start at the latest.
21. Place and time of the drivers' meeting.

203 - ENTRIES

203.01 - RATIFICATION

The National Authorities must ratify in writing any entry for drivers wishing to compete abroad.

Direct correspondence between the Organising Committee and foreign drivers is permitted but no entry is to be accepted unless approved by the driver's National Authority.

For international Championship, and cup events the correspondence is held between the National Authorities. The Organising Committee will keep blank entry forms at the disposal of the drivers.

An entry is not valid unless it reaches the organising committee within the time and with the fees paid as prescribed in the advance programme.

203.02 - ADMISSION

The Organising Committee has the right to decide whether the entrant is acceptable.

No National Authority, organising an international competition has the right to refuse the entry of a foreign driver duly commissioned by his/her own National Authority provided they conform to UIM rules.

For International titled events, the closing date for inscriptions may be set no later than 31 days (1 Month) before the event.

203.03 - ENTRY FEE

Each Organising Committee fixes the amount of entry fee for the competition.

Entry is valid only after payment of the entry fee.

The National Authorities have the right to establish a rule whereby higher fees are imposed on late entries.

203.04 - MINIMUM AGE AND IDENTITY

The minimum age for all drivers racing international races is 16 years.

Each National Authority has the right to fix a minimum age for the drivers allowed to race on its waters, such age restriction is to be shown in the advance programme.

The driver may only race under his/her name or the pseudonym written on the licence.

203.05 - NATIONALITY

The nationality of the driver only must be taken into consideration in the classification.

203.06 - PUBLICITY ON THE BOATS

Advertisements may be freely applied on the entire surface of the boat, but there must be a clear space of no less than 0,15 meter around the racing number.

No crew can be compelled to carry any advertising whatsoever on their person, clothes or upon the boat that is competing and their refusal to do so cannot in any way be an obstacle to their participation in any competition.

Penalties may be applied to any driver who, in the course of any sporting event, has made any advertisement contrary to the truth or distorting the facts.

Political, religious or immoral publicity advertisements are not allowed.

Any National Authority has the right to fix its own rules regarding publicity for its own boats and courses.

Should no publicity be admitted for an event, this has to be announced in the Advance Programme.

204 - EVENT INSTRUCTIONS

The Organising Committee must clearly state the following points in their competition instructions:

1. Places and dates of the race.
2. Layout of course drawn to scale :
 - Length of the course.
 - Direction of the course.
 - Starting line and its marks.
 - Finishing line and its marks.
 - Full details of buoys.
 - Full details of obstacles.
3. Starting time of each competition.
4. Signals for each competition.
5. Signals of postponement, cancellation, re-start and shortening of the competition.
6. Time when the control closes for each competition.
7. Full particulars of prizes for each competition.
8. Time limit and place for handing over the protests.
9. Time and place of the distribution of prizes.
10. Appeal procedure.
11. Composition of the Committee, of the Jury and of the Technical Commission.
12. List of boats entered for each competition and if possible, names and Clubs of the drivers.
13. Place and time at which written instructions will be issued. Where and when the official time is to be communicated and place and time of driver's meeting. A brief driver's meeting must be held before practice takes place.
14. Only drivers whose entries have been accepted by the organising committee have their names printed in the programme.

205 - SAFETY RULES

The safety rules of any competent National or International body in force for the area of the event shall be complied with. The Organising Committee shall comply with National Authorities' regulations.

Additional safety equipments to be carried on board of the competing boats and not mentioned or set out in these rules may be specifically required by the Organising Committee as it feels to be necessary . Such equipment shall be specified in the Advance Programme.

205.02 - TEST ON CONSUMPTION OF ALCOHOL

Competitors, team members and officials shall not be under the influence of alcohol during the entire racing event.

Testing when carried out shall be by using an alcoholmeter.

A competitor, team member or official shall, if requested by an authorised official, submit to an alcohol test. Written or verbal notification of selection for testing will be given to selected person by an authorised official. Refusal or failure to do so in time limit 15 minutes from notification may be taken as if a positive test had been ordered and dealt with accordingly.

For all International races, any competitor found to have more than 0.00 micrograms of alcohol in 100 milliliters of blood (0.00 on the breath analyzing machine) 1 hour before or during testing or racing shall be immediately suspended and disqualified from the whole event, except if the event is more than one day in which case the OOD/UIM Commissioner may order another test.

For all International races, any team member or official found to have more than 0.00 micrograms of alcohol in 100 milliliters of blood (0.00 on the breath analyzing machine) shall not be allowed in any area under the control of the race officials.

The results and any penalties are to be transmitted to the UIM; and to the National Authority (NA) of the driver's license, and the UIM NA of his/her passport, for further sanctions.

205.03 - ANTI-DOPING REGULATIONS

Anti-doping regulations based upon the world anti-doping code.

See separate section in this rulebook.

205.04 - NAVIGATION RULES

Being the competitions organised in free waters open to public navigation, all Competitors shall always conform with:

- The International Rules for Prevention of Collision at Sea. (COLREGS)
- The rules of any competent authority governing the use of pleasure craft in the hosting Country.

These provisions, if not known by foreign participants, must be communicated to them in writing. English will be the official language for any such notices.

206 - INSURANCE

All boats must be properly insured by themselves against any claims for damage to other boats and persons.

If in the Country where the competition takes place a special competition insurance is required by law, it shall be underlined in the Advance Programme, and the relevant fee recovered from the competitor.

The minimum insurance coverage required from the competitor must be specified in the Advance Programme.

207 - MEDICAL EXAMINATION

The Medical Officer who is present at the motor boating event has the right to require any driver entered to submit to a psycho-physical examination and /or an alcohol or drug test at any time before during or within 24 hours of the termination of an event.

The result of such examination will be immediately communicated to the Race Committee, who basing themselves on the report of the Medical Officer, may exclude the driver from the competition.

208 - DISTINCTIVE MARKS

208.01 - NATIONALITY

The national flag of the craft, painted in a rectangle 25 cm x 40 cm on the deck, the superstructure, or the vertical part of the sides, it must be visible on both sides of the hull.

208.02 - RACE NUMBERS

A competition number is allocated to every driver by his/her National Authority.

Should two drivers of an international competition have the same number:

- The driver of the hosting Country will change his/her number according to the organiser's instructions.
- If none of the drivers is from the hosting Country, the driver which entered last will change his/her number according to the organiser's instructions.

209 - ENVIRONMENTAL CARE IN RACE AREAS

209.01 - NOISE LEVEL

Every driver is responsible for demonstrating that his/her engine(s) does not exceed noise levels established.

209.02 - EXHAUST EMISSIONS

To reduce emissions as much as possible, all drivers are recommended to use lead free petrol and biodegradable lubrication oil.

209.03 - RE-FUELLING

Every care must be taken not to spill fuel or oil.

An absorbent carpet to avoid any spillage on to the ground must be used.

Suitable containers shall be provided in the pits area, to properly collect waste such as cans, containers, etc.

One person must be appointed by the organiser to be responsible for proper waste pick up and removal after the race, according to the procedures set by the Local Authorities.

210 - DISCLAIMER RULE

By participating in UIM governed races any participant (driver, team member, spectator, race official or other involved person) acknowledges the following:

U.I.M. is the governing rule making body of U.I.M. racing events which are responsibly organized by clubs, national authorities of UIM, contracted promoters or other organizers. These organizers do not act on behalf of the UIM and UIM is not responsible for any act or omission of such organizer and shall not be liable to the participant accordingly.

The U.I.M. sport and technical rules are intended to minimize risks but they cannot provide the highest possible safety standards at all times. Residual risks might remain.

Enforcement of the rules by UIM or other race officials and in particular but not limited to the technical scrutineering does not guarantee the safety of racing or the safety of the scrutineered boat. Scrutineering is not intended as a construction/ condition survey. The racing license issued by the National Authority or a super license issued by the UIM does not guarantee that a driver is physically able to race safely nor that he/she has sufficient experience or education.

Teams and drivers are solely responsible for their own safety including but not limited to their physical and educational ability to race in the relevant class, the safety of their boats and other gear and the safety of their racing activity. This responsibility includes racing with prudence and taking technical measures which are not mandatory in the rules but deemed necessary.

UIM shall not be liable for any damage, injury or death due to inadequate rules, breach of existing rules by participants or failure to enforce rules by the race officials.

GROUP 300 SPORTS RULES

300.01 - EVENTS

Pleasure Navigation events are created specifically to foster development of motor boating .

They may be divided in two main groups.

Pleasure Navigation activities :

- Competitions.
- Promotional events.

Competitions are run for pleasure craft where each crew may start individually following a course, a route and a time previously established. Different rules are set for the following specialities :

- Regularity competitions.
- Endurance competitions.
- UIM Trophies.
- Parallel slalom competition.
- American pursuit competition.
- Rally competition.
- Championships.

Promotional meetings are all the initiatives concerning pleasure craft and that can be summarised as follows :

- Rallies.
- Meetings.
- Treasure-hunt.
- Pleasure Navigation training.
- Navigation demonstration.
- Sea skill tests.
- Gymkhana : The rules governing these events are usually prepared each time by the organisers;

The rules governing these events are usually prepared each time by the organisers.

SOLAR or other alternative energies powered boats with in-water propulsion.

Radio Controlled Competitions of Radio Controlled powerboats are regulated by specific technical and sport rulebook.

Special and/or Experimental boats (Units not included in previous points).

TYPE OF EVENTS

- Regularity : declared speed competition - pursuit - slalom - social rally - competition rally.
- Endurance : races - speed - time declared - distance declared - index of performance.
- Promotion : - social rally - competition rally - meetings - skill tests.
- UIM Trophies Pavillon d'or.
- Historical boats : age of boats (min. 25 years) - presentation:- history - concours d'elegance - restoration.
- Solar or alternative energy powered boats with in-water propulsion.
- Radio-controlled : as per UIM international rulebook issued by the R.C. sub-commission.
- Special Experimental boats.

300.02 - DEFINITIONS

declared speed competition : the speed must be declared by the competitors. The average speed expressed in km/h (according to EC regulations) on the basis of which they will cover the course. Fractions of km/h are not permitted. Visible and secret controls will be done.

Pursuit: course definition - position of buoys.

slalom: defined start and finish (length of course) - buoy lay-out diagram - distance between buoys - parallax referred to the course axis.

COMPETITION-RALLY

- route to the meeting.
- special trials - meeting (theme event).
- seamanship test : navigation skill test, safety test, boat handling, docking etc.

300.03 - TIMING

In all international competitions and National championships, the timing is carried out by officially appointed timekeepers using certified timing devices graduated to one tenth of a second.

The devices must have a split second system, one part of which must be capable of being stopped and restarted, or any electronic of the same or better accuracy.

300.04 - COURSE

All courses may be measured on the spot by official surveyors or may also be measured on an official map or chart of not less than 1:25,000. depending on the type of competition. If the length of the course cannot be certified, the marks having drifted or for any other reason, the speed is not to be declared in the results. The organisers must ensure that the position of the buoys does not present any danger to the drivers. It is recommended that the pits be sited where possible away from the course on the outside.

COMPETITION CONTROL:

- Competition control should be situated so that the circuit can be easily seen and controlled.
- The competition should be observed by at least two persons :
 - the Officer Of the Day; or his/her assistant.
 - one or two Commissioners or one or two members of the Jury.
- The Officer Of the Day is the general observer, being in radio or telephone contact with the Deputy Officer Of the Day, the Safety Officer and the rescue team.
- The other two supervisors share the circuit in observation.
- The competition can only be stopped by order of the Officer Of the Day.

MARKS OF THE COURSE

- The Marks of the Course are any objects (boat, buoy...) that are specifically designated as such in the instructions.
- The objects that are not designated specifically as such are to be considered as obstacles.
- All floating marks (buoys) must carry an orange identification of 70x70 cm (28x28 ins.) except the mark on the starting/finishing line which carries a black and white chequered identification or a white and black striped identification.
- The safety zone (100 m) is defined by at least one buoy which carries a white and red chequered identification or a white and red striped identification.

- The buoys are to be made of rubber or similar material.

An Official is posted near the turning marks. He/she must observe the turning of the marks and report to the Race Committee. Should any mark be removed from its proper position either by accident or otherwise, the Officer Of the day shall, if possible, have it replaced. Should it be impossible to replace the mark in time for the boats to round it, the Officer Of the day shall decide whether the race is to be restarted or not.

SIGNALS FROM THE SHORE:

- Series call letter :

Signals are passed by means of "letters". These signals are rigid boards measuring 60 cm x 80cm painted on both sides with black letters on a white background :

Cancelled = N (no race);

Postponed = R (Retarded);

Shortened = D (Diminished);

Stopped = S (Stopped).

- Flag signals:

The flags used for signalling have the following meaning :

RED : to stop the competition and mark serious danger on the circuit ;

YELLOW : danger on the circuit.

BLACK : the driver to whom the flag is shown must stop ; this flag must be accompanied by the number of the boat which is to be stopped.

WHITE AND BLACK : Chequered :finish.

WHITE AND RED : Chequered : course mark showing the safety zone ;

ORANGE : course turning marks.

The distance between the starting line and the first turning buoy must be at least 500 metres.

300.05 - COMPETITION CANCELLED

The Committee has the power to cancel any competition should unfavourable weather or other serious circumstances render such action necessary. The letter "N" hoisted over the class or competition signal, indicates that such competition has been cancelled.

300.06 - COMPETITION POSTPONED

The Committee has the power to postpone a competition, in which case the letter "R" and the class letter are hoisted. Competitions thus postponed are subject to written notice on the notice board. The Officer Of the day may postpone the start, even after the first signals have been given, but only in cases of force majeure or if an error in the starting signals has been made.

In both cases, signalling is to be recommenced. When the need for postponement has passed, the Committee signals the start according to the instructions contained in the programme. New entries are not to be accepted for postponed races. Only drivers who duly entered and were present when the competition was postponed are admitted.

A race or heat must in no case be postponed more than 24 hours. If it is impossible to compete within this time, the other heats held will be used as a basis for classification.

300.07 - COMPETITION SHORTENED

A shortened competition is one run over a course which has been shortened by the Committee before the start. The decision with instructions about the shortened course must be notified by race bulletin to all teams, officials and marshalls.

300.08 - COMPETITION STOPPED

A stopped competition is one which has been interrupted by the Officer Of the day after the start. Stopping the competition is decided by the Officer Of the day for reasons of which he/she is the sole judge. A competition must be stopped when anybody is in the water as a result of an accident (blow over, roll, submarining, collision, etc.) as the continuation of the competition constitutes a danger to those involved. Restarts are given as soon as the course is cleared. A boat disqualified during a stopped competition is not allowed to restart. No new entry is accepted for a restarted competition/heat. Any penalty incurred in a competition which has been stopped is taken forward into any restart of that race.

300.09 - DISTINCTIVE MARKS

Distinctive marks and the competition number must remain visible during the whole race.

The absence or loss of the competition number or part of that number leads to the disqualification of the boat.

300.10 - INSURANCE

Evidence of the insurance coverage shall be produced before the start.

300.11- SAFETY EQUIPMENT

Every competing boat shall have on board during the whole duration of the event (including practice) all the following:

- The efficient safety equipment required by the Country whose flag is flown by the craft.
- Any safety equipment prescribed by these rules or the competition rules.
- During race and practice each person aboard a boat must wear a racing vest and protective clothing conforming with rules 502.03.07.10 and 502.03.07.13.
- If required by the competition rules, any person aboard any boat taking part in competitions must wear a helmet conforming with rule 502.03.07.11.
- Restrained drivers must wear a head and neck support/restraint device conforming with rule 502.03.07.12.

300.12 - FIRST AID STATION

A first aid station with qualified medical staff must be available in the vicinity of the competition area.

The Organising Committee must alert it before the competition and a procedure for urgent calls must be agreed between the race Medical Officer and the coordinator of the First Aid Station.

300.13 - TECHNICAL PROTECTIONS

- Pleasure craft participating in competitions shall be equipped with a security cut-off / Kill switch device except for: craft competing in regularity competitions, craft driven solely from the cabin. (except for races)
- At any stage of the event, it is forbidden to start the engine of a boat while its propeller is out of the water.

If a boat owner's National Authority does not have a measurer qualified to measure his/her particular boat/class, the owner may ask his/her National Authority to contact another National Authority to have their fully qualified measurer inspect his/her boat.

The UIM establishes and maintains a "Group of International Measurers," consisting of persons from any National Authority that are fully qualified to measure boats for international racing classes. All National Authorities are asked to forward the names of persons qualified for this group. The UIM will name a chairman for the group who will be responsible for checking and certifying the ability of each member of the group.

301 - REGULARITY COMPETITIONS

301.01 - DECLARED SPEED COMPETITIONS

1. The speed must be declared by the competitors, after the first training for the announcement at the first driver briefing following the first training. The average speed expressed in km/h (according to EC regulations) on the basis of which they will cover the course. Fractions of km/h are not permitted.
2. Such speed shall be constantly kept from the start in the termination of the competition, passing the visible and secret controls set along the course.
3. All designated waypoints shall be passed, or rounded, within a distance equivalent to one length overall of the competitor boat, and a straight seaman-like course should be followed at all times.

Every boat shall carry a crew made up of a driver and a navigator:

- a) other members of the crew can be carried up to the number specified in the homologation documents.
- b) if the boat is not homologated, in addition the driver and the navigator, it may carry additional crew as follows:

Overall length	Additional Crew
from 2 to 3,5 m.	none
from 3,5 to 4,5 m.	none
from 4,51 to 5 m.	one
over 5 m.	three

All people on board must be members of a National Authority.

4. In accordance with local Authorities regulations, the Organising Committee can provide for speed limits for certain sections of the course or establish neutral sections. This must be clearly specified in the competition rules and such sections must be shown on the nautical chart of the course.
5. The Organising Committee fixes speed values.
The speed values must be included in the advance-programme.
6. Irrespective of whether the competition course is in confined river waters or the open sea, the International Regulation for the Prevention of Collision at Sea (COE, REGS) shall apply, unless local by-laws are in force. In the latter case these prevail.
7. Start
Starts are made according to the speed values declared by the competitors, beginning from the lowest speed declared.
Start must be given with at least one minute interval between competitions.
8. Course
The course will not be shorter than 50 km. for additional competitions.
The course will not be shorter than 100 km. for W.C and C.C.
If this overall distance is achieved by a number of laps, no lap will be less than 8 km.

9. Visible controls

At least 2 (two) controls for national competitions and 3 (three) controls for W.C. and C.C. shall be placed on the course, other than the starting line. The control is ashore with a clear reference in the water (orange Buoy) placed at right angles to the track.

The visible control can also be a pre-fixed point on the course, whose coordinates are specified; alternatively, a boat may be on the pre-fixed point acting as the Control with coordinates ashore. The boat shall carry a Timekeeper and a Buoy Marshall.

10. Secret controls

At least 1 (one) secret control for national competitions and 2 (two) secret controls for W.C. and C.C. shall be placed on the course. It must be sited where it is possible to record the competitor's passage having coordinates at right angles to the track.

11. Competition track

On submitting an entry, the competitor will receive a nautical chart relating to the area of the competition, scale of at least 100,000 where the course is shown.

This chart must show the minimum distance in km. between the starting line and the first visible control point; between this control and the following one and so on to the finishing line.

The sum of such distances must be equal to the total length of the course.

12. Timing and passage recording

Timing and passage recording at all the control points is carried out by the Official Timekeepers. Times are recorded to the nearest tenth of second as the bow of the boat breaks the control line.

This is compared with the theoretical passing time consequent to the declared speed, causing a positive or negative difference (expressed in seconds and tenths of second).

13. Race results

- a) Results are to be expressed in terms of percentage error against the predicted speed.
The winner will be the boat with the lowest percent error.
- b) Before calculating results, possible protest or communications must be examined for which decisions must be taken by the Officer of the Day in conformity with the Rules.
- c) Any protest must be submitted in writing to the Officer of the Day, or his/her nominated Deputy within one hour of crossing the finishing line.
- d) Timekeepers make the sum of all the differences of time recorded at the visible controls. The resulting sum to be expressed in seconds and length of second.
- e) The differences of times recorded at the secret controls will be calculated in a similar manner.
- f) The total time differences resulting from the visible controls sums, plus those of secret controls, are then used to calculate the error against the theoretical course time related to the predicted speeds.
- g) In the unlikely event of a tie, the slower craft shall be declared the winner having spent the longer time on the water.
- h) In case of a tie the following progressive parameters shall be considered:
 - The slower boat shall be declared the winner
 - Time gap in excess (late passage) at the visible controls
 - Time gap in excess (late passage) at the secret controls

14. Penalties

The competitor who clearly modifies his speed in the proximity of the visible controls by zigzagging or stopping, will be penalised with 10" equal to 10 penalties.

The competitor who, next to the finishing line, clearly modifies his speed by zigzagging or stopping will be penalised with 10" equal to 10 penalties.

15. Disqualification

Reversing entails disqualification.

303 - POINT TO POINT COMPETITION

Point-to-Point racing is designed for sea worthy, offshore craft capable of undertaking independent, extended offshore passages in unprotected waters. Although a race between Boats, a competitor can also achieve a Class or Overall National or World Record.

303.01 – RACE / RECORD

Point to Point Competition is held on offshore Waters where competitors race from a pre-determined Point A to a pre-determined Point B. A National or World record may be set for the fastest lapsed time over that course during the race. This applies to Class records and the Overall record.

303.02 - RACE COURSE

Race Courses must be greater than 50 Statute Miles – 80 Kilometers.

All routes are reversible.

If a Point to Point record time is set during a race from points A to B, This record can be beaten and replaced by a faster time whilst racing from Points B to A. The start and finish positions from A to B must be the same as B to A.

Only fixed points of land, fixed navigational beacons or other charted fixed objects can be used as reference points though they need not necessarily be sighted. In special cases, pre-approved by the Observer, such as positions derived from satellite navigation systems are acceptable.

303.03 - CATEGORIES AND CLASSES

- 3 Classes: A / B / C
- 2 Hull Categories: V Hull / Catamaran
- 5 Length categories: see Rule 503.02
- 3 Class parameters; see Rule 503.02

303.04 – COMPETITION RULES

303.04.01 – MISSED MARKS

All competitors using electronic chart plotters should enable the tracking function using settings suitable for recording their track throughout the event at an update rate of no less than one point per minute. In the event of any dispute regarding their correct completion of the course, failure to make this tracking information available to Event Officials may reduce the competitor's chance of successfully avoiding a penalty or disqualification.

303.04.02 - OVERTAKING

At all times, the "Rules of the Road" shall apply. When two boats are on the same course the overtaking boat shall keep clear of the boat being overtaken and in passing shall allow at least 50 feet of clear water between them. The overtaken boats shall not alter course so as to compel the overtaking boats to pass within the 50-foot limit.

303.04.03 - FUEL

Fuel transfer at sea is only permitted between your own fixed on board tanks. Fuel may not be stored or carried on board in any jerry-can type of container. Ship to ship or air to ship refueling at sea is not permitted.

303.04.04 - ASSISTANCE

Unless specific in racing instructions, no outside assistance (including refueling is allowed during a race.

No changes to the boats systems may be made from outside during races (i.e., no radio command links to adjust onboard parameters to engine management systems, either air/fuel ECUs or ignition ECUs).

For all classes, it is permitted to use electronic steering compasses and/or electronic position fixing equipment. It is expressly forbidden to interface any of this equipment to the steering system. The Race Committee has the right to decide whether there was outside assistance or not.

A boat may be anchored or beached during the record attempt but any repairs must be made entirely by the crew without outside resources or materials. During any such stops, the timing of the voyage continues.

Any competing boat may be towed and if a tow is accepted, then that competitor will be treated as a retirement from the event or from that particular leg of the event competition. Alternatively, when a tow or other outside assistance is obtained, the attempt shall return to the last officially recorded "own power" position before resuming.

If a "without assistance" boat receives a tow the attempt, then fails or becomes "with assistance."

Once retired or finished with an event leg, competitors may utilize outside assistance to effect repairs to machinery, structure, navigation or safety equipment once berthed in a recognized port or marina.

303.04.05 – TIMINGS

The Time keeper will determine the Official Start Time for each Competitor/Race Boat

The moment of starting and finishing a Race/record passage must be recorded to the nearest second using GMT.

Details of the timepiece used must be logged and signed for by the observer or his/her appointee.

Records will be defined average speed and elapsed time.

The average speed for each passage shall stand until the average speed of that record has been reduced by at least 1%. Every request to ratify a record shall be considered in time and date order.

303.04.06 – RECORDS

Records will be recognized for passage between pre-determined points providing all relevant rules and independent observation are established, maintained, and ratified.

It is not allowed to do any records single-handed that require duration longer than 6 hours.

The World Record will be the shortest time, without handicap, which establishes the shortest elapsed time in accordance with these rules.

A record achieved during a race is listed as a race record and an outright record. If, however, an individual performance over the same course betters a race and outright record, it will only be listed as an outright record.

303.04.07 – BOAT SAFETY

Open cockpit boats capable of exceeding 80mph are required to submit a CV to the Event Organizer for all pilots. The CVs are subject to review/acceptance by the Event Organizer.

The entry organizer has the right to refuse any boat considered unsuitable and /or which does not conform to the requirements of the rules. The reasons for refusal shall be submitted to the team in writing.

303.04.08 – EVENT POINTS – AWARDED BY CLASS & LENGTH

Order of Finish	Points Awarded*	Pilot Points Awarded**
1	100	50
2	90	45
3	81	40.5
4	73	36.5
5	66	33
6	59	29.5
7	53	26.5
8	48	24
9	43	21.5
10	39	19.5
11	35	17.5
12	31	15.5
13	28	14
14	25	12.5
15	23	11.5
DNF	10	5
DIS	0	0
DNS	n/a	n/a

* For each legally started boat that was beaten, add 5 points.

** For each legally started boat that was beaten, add 2.5 points.

For example, a boat that finishes ahead of 5 other legally started boats will receive 25 additional points and the pilots will be awarded 12.5 points each.

Pilot Standings – awarded by Class

Pilot Standings are awarded by class (A, B, CC).

A pilot may have a standing in more than one class.

The accumulation of the Pilot Points is by class for any three of the last five races. That total determines a Pilot's Overall Standing.

Penalties to be determined by Event Organizer.

Smoking in the defined wet or dry pits	\$
Fuel transfer in pits or outside designed fueling areas	\$
Misrepresentation or providing untrue statements	Disqualification
Missed mark	Disqualification or time penalty as decided by Event Officials
Entering an exclusion zone on the plane	Disqualification or time penalty as decided by Event Officials
Spilled fuel or oil	\$ for first offense \$ for each subsequent offence.
Launching violation	\$
Failure to return event trackers (within 2 weeks)	\$
Improper/unsportsmanlike conduct – Abusive or obscene language	Disqualification or time penalty as decided by Event Officials
Breaking out of speed bracket *	<=5 break outs → 1 minute added to finish time for every breakout reading. >5 breakouts → 2 minutes added to finish time for every breakout >10 breakouts → Dis-qualification Breakout reading of > 5mph above bracket immediate disqualification

*A speed breakout is any speed that goes above the class speed for a duration of time that exceeds 3 seconds. A breakout speed with a duration time that measures 3 seconds or less will not be counted as a breakout.

303.05 - RACEFORMAT

The starting order of the competitors is communicated by the O.O.D. before each heat.

Start is given by an acoustic signal.

303.06 - HEATS

a) The race is run in three heats:

First qualification heat.

Second heat.

Third heat.

b) First qualification heat - 3 laps

Each competitor, individually, makes three laps of the course. For his/her qualification to the second heat the best time of the three laps is taken into consideration.

c) Second heat - 5 laps

Considering all the times recorded in the first qualification heat, irrespective of the categories, a progressive classification is made starting from the lowest time.

On the basis this classification, the two by two coupling for entering the second heat is made. Therefore, the first two by two result to be consisting of the first and second time, the second two by two by the third and fourth time and so on. If the number of competitors is odd the last will race alone and makes his/her own heat.

d) Third heat - 5 laps

Considering all the times recorded in the second heat, again the time classification is made and also the new two by two is determined. The first two by two is made by the first and second time, the second two by the third and fourth time and so on. If the number of competitors is odd the last will race alone and makes his/her own heat.

303.07 - STARTING ORDER

The starting order of the two by two, in the first heat is determined by ballot, while in the second and third it is determined by the highest time.

303.08 - FINAL CLASSIFICATION

For each competitor, the best lap time on the first heat and the total time of the second and third heat are added together. This total time, expressed in seconds, is then multiplied by the pertinent compensation coefficient ; this calculated time will determine the final classification.

303.09 - DISQUALIFICATION

Failing to respect rule "303.01.e" determine the disqualification of the competitor.

303.10 - PURSUIT RACES - COMPENSATION COEFFICIENT SCHEME

Compensation Formula: Time(expressed in seconds) x Coeff. Kt = Score

BOATS WITH OUTBOARD

4 Stroke	2 stroke	Class	Coeff. Kt
up to 550cc	up to 550cc	A	0.93
551cc - 1,000cc	551cc - 750cc	B	1.18
	751cc - 1,100cc	C	1.22
	1,101cc - 1,500cc	D	1.28
	1,501cc - 2,000cc	E	1.37
	2,001cc - 2,600cc	F	1.41
	2,601cc - 3,000cc	G	1.46
	3,001cc - 4,000cc	H	1.50

INFLATABLE WITH OUTBOARD

4 Stroke	2 stroke	Class	Coeff. Kt
up to 550cc	up to 550cc	A	1.00
551cc - 1,000cc	551cc - 750cc	B	1.24
	751cc - 1,100cc	C	1.29
	1,101cc - 1,500cc	D	1.36
	1,501cc - 2,000cc	E	1.47
	2,001cc - 2,600cc	F	1.51
	2,601cc - 3,000cc	G	1.56
	3,001cc - 4,000cc	H	1.58

Boats with i.o.b. Or i.b.

4 Stroke	2 stroke	Class	Coeff.
	Kt up to 1,350cc	A	1.26
	1,351cc - 5,700cc	B	1.38
	5,701cc - 7,450cc	C	1.47
	7,451cc - 8,200cc	D	1.55
	8,201cc - 10,000cc	E	1.65

INFLATABLE WITH I.O.B.

4 Stroke	2 stroke	Class	Coeff.
	Kt up to 1,350cc	A	1.29
	1,351cc - 5,700cc	B	1.40
	5,701cc - 7,450cc	C	1.46
	7,451cc - 8,200cc	D	1.59
	8,201cc - 10,000cc	E	1.71

304 - PARALLEL SLALOM COMPETITIONS

304.01 - CATEGORIES AND CLASSES

This event is open only to pleasure craft duly homologated.

To slalom competitions the following pleasure navigation categories may participate, each of them divided into classes according to their motorisation :

- Inflatable with outboard.
- Inflatable with out/inboard.
- Boats with outboard.
- Boats with out/inboard and inboard.

304.02 - CLASSES

Each category is divided into classes as specified in Group 500 rules.

304.03- COURSE

Two parallel slalom courses (course A and Course B) of equal length, They shall have a minimum of 150 m in length and be at least 50m apart from each other.

The courses shall be marked with a large buoy at each end, and eight smaller buoys spaced at equal-distance along the course.

The actual course dimensions shall be specified in the Advance Programme.

304.04- CREW

Only one driver shall be on board of each boat.

304.05- HEATS

Heats are drawn before the start according to the relative category and class. Two competitors participate in each heat and draw to start in course A or B.

Boats of different categories / classes may run together.

304.06- START

Boats will be aligned at the start line of the course with power on.

The starting signal will be given by the Officer Of the Day.

304.07- RACE RESULTS

Competitors will be timed, to complete the course alternatively slaloming the intermediate buoys.

Competitors then exchange the course and again will be timed to complete the course in the reverse direction A combined time is obtained by adding together the time of the two runs.

For each competitor a final time is then calculated: $((\text{time 1} + \text{time 2}) \times (\text{Kt coefficient})) + \text{time penalties}$

The pertinent compensation coefficient "Kt" is found in the "Kt" table, which is part of these rules.

304.08- PENALTIES

A competitor receives a 20 second penalty for each missed buoy. A missed buoy shall not be re rounded.

304.09- FINAL CLASSIFICATION

The winner is the driver who, among all categories, establishes the best calculated time.

304.10- PARALLEL SLALOM - COMPENSATION COEFFICIENT SCHEME

Compensation Formula: Time(expressed in seconds) x Coeff. Kt = Score

BOATS WITH OUTBOARD

4 Stroke	2 stroke	Class	Coeff. Kt
up to 550cc	up to 550cc	A	0.93
551cc - 1,000cc	551cc - 750cc	B	1.18
	751cc - 1,100cc	C	1.22
	1,101cc - 1,500cc	D	1.28
	1,501cc - 2,000cc	E	1.37
	2,001cc - 2,600cc	F	1.41
	2,601cc - 3,000cc	G	1.46
	3,001cc - 4,000cc	H	1.50

INFLATABLE WITH OUTBOARD

4 Stroke	2 stroke	Class	Coeff. Kt
up to 550cc	up to 550cc	A	1.00
551cc - 1,000cc	551cc - 750cc	B	1.24
	751cc - 1,100cc	C	1.29
	1,101cc - 1,500cc	D	1.36
	1,501cc - 2,000cc	E	1.47
	2,001cc - 2,600cc	F	1.51
	2,601cc - 3,000cc	G	1.56
	3,001cc - 4,000cc	H	1.58

Boats with i.o.b. Or i.b.

4 Stroke	2 stroke	Class	Coeff. Kt
	up to 1,350cc	A	1.26
	1,351cc - 5,700cc	B	1.38
	5,701cc - 7,450cc	C	1.47
	7,451cc - 8,200cc	D	1.55
	8,201cc - 10,000cc	E	1.65

INFLATABLE WITH I.O.B.

4 Stroke	2 stroke	Class	Coeff. Kt
	up to 1,350cc	A	1.29
	1,351cc - 5,700cc	B	1.40
	5,701cc - 7,450cc	C	1.46
	7,451cc - 8,200cc	D	1.59
	8,201cc - 10,000cc	E	1.71

305 - HISTORICAL BOATS COMPETITION

305.01

Historical boats are those which meet the minimum requirements of the UIM-ASDEC certification.

305.02

Historical boats which have obtained the UIM-ASDEC certification with a total score of at least 53,5/210 and with none of the evaluation parameter having scored zero points, meet the minimum requirements of points 317.00.01 and have the right, upon request, to be listed on the National Authority - ASDEC Nautical Historical Register.

305.03

All the historical boats as defined in are entitled to enter UIM - ASDEC events and competitions organised solely for historical boats according to ASDEC sport rules.

305.04

The above mentioned boats may also participate in UIM regularity competitions, where if required, special reduced speed and length of course may be used. Such rules modifications must be specified in the advance programme of the event.

305.05 - EVENTS FOR “HISTORICAL” BOATS

There are four different types of event :

- STATIC SHOWS;
- “RENDEZ - VOUS”;
- MEETINGS;
- RAID ON HISTORICAL AND CULTURAL COURSES;

305.06 - LICENCES

In order to participate in “Rendez-vous”, Meetings and Raids, drivers and boats shall have the documents and legal insurance.

That is to say : Navigation Permit, Nautical Driving Licence, Insurance R.C. Licence for radio devices, if on board. Or the documents corresponding to the Navigation Permit and to the Nautical Driving Licence issued by the relative National Authority for calendar events, that is to say : Certificate of UIM/ASDEC Classification Competitor Licence, issued by the relative National Authority.

In case of events abroad, the rules of the Organising Country shall be respected.

305.07 - UIM CHAMPIONSHIP

Competitors who participate, even with different boats, in at least three calendar events with final results, can compete for the title.

The title will be awarded according to the sum of the points obtained with the three best positions reported in the general classifications of three events.

In case of a tie the winner will be the driver who obtained the best sum of points, as for the calendar events considered, in UIM/ASDEC certification.

Jury, Race Officers, Timekeepers

- The jury of the event is composed by three people, notably the Officer Of the Day who is the president.
- The Officer Of the Day is designed by the National Authority, the other two components, the Race Secretary and the third judge are appointed by the Organising Committee.
- The UIM/ASDEC certification is issued by three Certifiers appointed by National Authority.
- At least one of the three Certifiers shall be registered in the Certifiers' Register.
- The timed events, where the time is the evaluation priority, shall be timed exclusively by Official Timekeepers.
- The general classification will be obtained by summing the points assigned in the different events, UIM/ASDEC classification included.

Logbook

The logbook follows the naval activity and the social life of boats registered in the Historical Naval Registry. The logbook is therefore linked to the boat and to the possible transfers of property. It cannot be transferred to other boats, even if they are owned by the same partner.

The Organising Committees of UIM events record the participation of the boat and the result obtained, in the logbook; moreover, in case the boat participates in raids, stamp controls are recorded.

The ship owner can record in the logbook : single or group cruises or raids of a particular importance (because of the subject, the difficulties, the extraordinary events, the distances or the unusual places etc.). In such cases, it is suggested to previously inform the National Authority.

The cost of the Logbook is decided annually the National Authority.

305.08 - STATIC SHOWS

Definition

Static Shows are parades of “Antique” or Classic boats on the ground.

They can be either single events or coupled to Elegance Contests or Barter-Shows. They can also be complementary to “Rendez Vous”, Meetings and Raids.

Rules

The special rules and the Program shall be drawn up by the Organising Body of the event and previously approved by UIM

They must specify and provide for :the venue, dates and modes of registration, times for any control and the distribution of the registration number, the allocation of the exposition site and the delivery of the Rules.

They shall also specify the procedure for the prize giving.

The Classification of UIM/ASDEC Certification is not requested.

Prizes are awarded, by irrevocable decision of the Jury, according to the peculiarities of the boats.

305.09 - “RENDEZ - VOUS”

Definition

“Rendez - Vous” are non-competitive events, aiming to gather amateurs in fixed venues and dates, with a recreational, evocative, tourist and cultural goal.

An event is an exhibition of boats in the water, with a demonstrative parade and possible common routes in typical places.

In addition, Elegance Contests, Static Shows and Barter-Shows can be organised.

Rules

The special Rules and the Program shall be drawn up by the Organising Body and previously approved by UIM

The Rules, in addition to what is established for the Static Shows, shall provide information about clothing for the teams.

The Classification of UIM/ASDEC Certification is not requested. 014 Prizes are awarded, by irrevocable decision of the Jury, according to the peculiarities of boats and teams.

305.10 – MEETINGS

Definition

Meetings are events aiming to gather amateurs in fixed venues and dates, with the same goal as the “Rendez-Vous” and, like these last ones, with the possibility to have in addition Elegance Contests, Static Shows and Barter-Shows.

Unlike “Rendez-Vous”, meetings are characterised by the presence of competitive races, enhancing the sporting aim, with a general classification possibly valid for the UIM Championship.

Rules

The special Rules and the Program shall be approved by the National Authority and registered in the Calendar.

The program shall specify dates and venues for any activity of the event. A meeting shall include a UIM/ASDEC Certification test and at least two basic competitive races. Such races shall respect the provisions of the Sport Rules.

Basic Tests are the following : -UIM/ASDEC Certification Test-Regularity Race-Sea Skill Tests (Rescue of a man at sea and manoeuvre, mooring test and manoeuvre).

Subsidiary Tests are the following:-Slalom -Parallel Slalom -Treasure-hunt-Water Gymkhana -Knots Test and nautical techniques-Knowledge of security and prevention rules and of the pleasure navigation rules-Skill test in nautical games-Naval Etiquette Test.

For subsidiary tests which do not contribute to the creation of the general classification, there are no set rules. The pertaining special rules will be drawn up by the Organising Committee.

Final Results shall be foreseen:

Final results for any race A general classification resulting from the points obtained in the three basic tests, which is to say in the ASDEC certification test and in the two competitive races.

Prizes : A prize to the first in any test (basic and subsidiary), and eventually to a second and a third must be foreseen. A prize to the first three in the general classification. Possible additional prizes shall be specified in the program.

305.11 - HISTORICAL AND CULTURAL RAID

Definition

Raids are tourist - sport - cultural events which take place on routes recalling facts of power boating history or on cultural and naturalistic routes.

They consist of a navigation, also in stages, taking place according to a fixed schedule, in compliance with rules, limits and places.

Along the course transit and stamp controls shall be established.

Rules

As for the other events with a General classification, Rules and Program shall be approved by the National Authority and registered in the calendar, according to the specified provisions.

Particularly

Every driver receives a navigation schedule where control stamps can be affixed, if the competitor does not possess the Logbook; a detailed travel map, with the relative progressive mileage, the position of the transit controls, the theoretic transit time, the site, the maps of the venues and the characteristics of the basic tests foreseen; any other information on the program.

Starts

Starts are given as specified in the programme as for the transfer stages to the stamp control positions, at the time foreseen on the navigation schedule.

If the driver does not appear on the starting line at the set starting time, he/she is penalised by one point for every second of delay and he/she is excluded from the final results after 15 minutes from the starting time.

Controls

Along the course stamp controls are placed in the sites shown in the map and on the finishing line.

A delay at the controls, compared to the schedule, implies a penalty of one point for any second of delay or advance.

Competitors arriving at to the control points in groups will obtain the same time.

The absence of a control stamp implies the exclusion from the final results.

At any control and at the stage arrival a maximum delay of 60 minutes is permitted, compared to the time foreseen in the schedule, always with a penalty of one point per second, over which the competitor is excluded from the final results.

Penalties

In addition to penalties due to the times to respect, as described above, penalties due to behaviour during navigation are foreseen:

Any violation of the Naval Etiquette and an improper use of fenders implies a penalty of 5 points per infringement.

The non-respect of one rule of behaviour for the Prevention of Collisions, if directly reported by the Jury or following proved claims, implies 15 points of penalty.

Additional basic tests

The tests specified in the program can be performed during the course, (at the arrival or starting of a stage) or at the final arrival.

For rules and penalties, see what is specified for basic tests.

Scoring system

The scoring system for the Raid is drawn up starting from the basic score of 140 points and deducting the points of the different penalties.

The General Classification is the sum of the points of the Raid Final Results with the points of the final results of the basic competitive race and the points of the Classification of UIM/ASDEC Certification.

305.12 - RESCUE OF A MAN AT SEA AND MANOEUVRE

Definition

This kind of test is a sea skill test. Accuracy and behaviour determine penalties for the evaluation of the test.

Rules

In a designated area equipped with buoys and easily controllable by timekeepers and jury, competitors must: cast the moorings off, navigate in a set course, in the fixed direction, launch a lifebelt in the water, make a 180° evolution and recover the lifebelt with any means.

Repeat the set course in the fixed direction and take the mooring back.

Competitors will receive the map of the venue when they submit for their entry.

Accuracy and behaviour

The performance of the test is evaluated with penalties charging the basic score, equal to 140 points.

A maximum time must be specified, over which disqualification is foreseen.

The time spent is the time calculated between the starting sign and the termination of the mooring manoeuvre, when the test is concluded.

305.13 - SCORING SYSTEM (SUMMARY)

Events

Theoretical score that can be obtained in the general classification of any event is a maximum of 450 points. It is the sum of the highest points obtained in the basic tests. Particularly :

- Theoretical maximum score in UIM/ASDEC Certification test: 210 points;
- Theoretical maximum score in sea skill test and RAID: 140 points;
- Theoretical maximum score Regularity race: 100 points;

Regularity test

Max. score : 100 / A penalty of 1 point for each sec.

Name of the boat	N° :	Competitor :
Declared Speed :	N.M :	= km/h :
Departure time :	Arrival time :	
Effective used time :	Ideal time :	
Effective secret time :	Ideal time :	(at invisible check points)
Total penalties:		

Manoeuvring competition

The classification is determined by reducing the penalty points from the 140 points. For each penalty a rating from 0 to 10 will be given ; the perfect score, being conventionally "0".

Name of the boat	N°	Competitor :
1. Dressing Penalty;		
2. Hoisting and position of the flags;		
3. Use of fenders;		
4. Hitting or risk to hit the pontoon;		
5. Hitting or damaging buoys during competition;		
6. Error of the course;		
7. Touching of moving boats or bad manoeuvring whilst rescuing a man at sea (lifebelt);		
8. Docking lines (right diameter and length);		
9. Docking knots (ability to execute);		
10. Number of persons on board during manoeuvring in function of the length of the boat;		
11. Smoke and noise pollution during the manoeuvring;		
12. Professionalism of the team;		

13. Boats characteristics (single or multiple engines, beam, length and outer keel dimensions / flying bridge etc.);
14. Maximum allowed time : Effective time.....;

TOTAL POINTS Note :

Exceeding the maximum time allowed or not completing the competition will result in disqualification. Boats characteristics will influence its manoeuvrability. Number of engines, kind of outer keel, structure of flying bridge will determine number of handicap points (0 - 10).

306 - RALLY COMPETITION

A Rally is a concentration of pleasure boats at a time and place established by the Organising Committee.

The venue must be reached following a specified course, in one or more stages.

Along the course and/or at the venue regularity competitions will take place.

Such competitions will be organised in accordance with the relevant UIM rules and will score points for each participant ; the total of all points awarded will establish the final result.

The winner is the boat with the lowest number of penalties.

The points for each stage are scored according to the UIM scoring system (400, 300, 225, etc.).

Difficult sections may be introduced into the course : in this case the event is called RALLY MARATHON and points are scored to be included in the final results.

All stages must be specified in the competition programme.

The Organising Committee will draw up the Rules to conform with the features and facilities of the venue.

The event may take place on one or more days.

During the event at least two regularity competitions must take place, one of which shall be a parallel slalom or American pursuit.

During parallel slalom and/or American pursuit, all the relevant UIM rules shall apply.

The boat will only carry the number of passengers established by the homologation sheet of the craft. In the absence of this document, the relevant "regularity competition" rule applies.

All routes, averages, passage controls, regularity competition, parallel slalom, American pursuit etc. will be kept secret until revealed to competitors when the documents are distributed by the Organising Committee at the start.

Such documents shall specify the length of the course, type and number of the stages, maximum times allowed.

At the start every competitor will be given a schedule, for which the driver is solely responsible.

The schedule shall be presented at each check point.

Absence at any control, loss of the schedule or falsification of the document shall incur disqualification.

On-board Equipment shall comply with the regulations of the boat's flag Country.

Procedures for stage starts will be established by the organisers.

Penalties will be established by the organisers.

The Organising Committee is empowered to establish rules for any event not covered by the UIM rules.

Such rules must be specified in the Advance Programme.

The points in each individual competition are added together to provide the total points for the event.

307 - PROMOTIONAL MEETINGS

Activities

Promotional meetings are all non-competitive events, used to promote pleasure power boating and may include one or more of the following activities:

1. Passages;
2. Meetings;
3. Treasure-hunt;
4. Pleasure Navigation training;
5. Navigation demonstration;
6. Sea skill race;
7. Gymkhana.

A Meeting is a concentration of boats at a time and place specified by the Organising Committee, with the aim of exchanging new experiences in navigation, and techniques concerning power boating in general. Meetings may be one-design, organised by boat/engine manufacturers or other companies involved in power boating, in co-operation with an Association affiliated to the National Authority.

All these events must be authorised by the National Authority, to which the request must be submitted within set deadlines, in order to obtain the permission of the relevant Authorities. Sporting Pleasure Navigation Events may be organised within meetings, in accordance with the UIM rules.

The General Rules for Pleasure Navigation and the relevant regulations must always be observed by organisers and participants.

The rules for treasure-hunts or sea skill events must be deposited with the National Authority with the request to organise. The events of Pleasure Navigation training do not need specific rules. Only a timetable is necessary for events of Navigation, demonstration and sea skill race.

Gymkhana consists of a series of different skill competitions, as for example the recovering of a man at sea, mooring, landing and starting from the shore, anchoring to a buoy etc. The course, competitions, penalties and points shall be specified in the programme.

A Passage is a course exceeding 500 km, both at sea and on inland waters or both, without minimum and maximum times and special heats. Drivers wishing to organise a passage must apply to the relevant National Authority, enclosing details of the course they wish to follow and a log book. The National Authority will authenticate the pages of the log book with an official stamp.

At the end of the Passage, the logbook will be submitted, together with a photocopy to the National Authority for its homologation procedure. The course shall be authenticated by local Authorities certifying the logbook at appropriate points. The competitor(s) may extend the established course by means of certifications in the logbook. Should bad weather stop the passage before the minimum programmed length specified above, it may be re-run by notification to the National Authority and using the same logbook. The National Authority will note the rerun of the Passage, specifying the new date of the event.

308 - ELECTRIC AND SOLAR PLEASURE CRAFT

Solar or other alternative energy powered boats with in-water propulsion.

They may participate in all the competitions specified in these rules, with independent events relevant to their particular characteristics.

When the Organising Committee submits rules to their National Authority, these must include courses, speed, classes, and all other relevant details.

GROUP 400 JURISDICTION

400 - JURISDICTION

401.01 - DEFINITIONS

Jurisdiction applies to:

The UIM Aquabike, Circuit, Motosurf, Offshore and Pleasure Navigation Rules.

401.02

No claim for damages arising from an infringement of any of the UIM rules or the advance notice or any of the race instructions or race bulletins shall be adjudicated upon by any race committee or appeal authority but shall be subject to the jurisdiction of the courts.

The crew of a racing powerboat which acknowledges infringing a rule does not thereby admit liability for damages.

The findings of fact, and the decision of the Race Jury shall be relevant only to the purposes of the powerboat racing rules and shall not be referred to in any proceedings for damage without the written consent of all parties to the protest.

402 - JUDICIAL BODIES

402.01 – THE INTERNATIONAL JURY

The Jury hears any protest raised by a driver.

1. Composition

The Jury must be composed of at least three members, the Chairman included. The Organisers of the event appoint the Chairman. Each competing country, including the hosting country, may appoint one member delegate who can represent only one country. These appointments must be made in writing, authorised and signed by a National Authority Official and delivered to the event Secretary.

If there are not enough NA appointed members to form a Jury of three persons, the Organisers must appoint additional members, but only enough to reach three persons.

The Jury composition will be announced at the first drivers meeting. The jury must be present at the first drivers meeting.

Race Officials cannot be Jury members.

The appointed UIM Commissioner(s) to the event is (are) full member(s) of the Jury.

In an event comprising races of several classes, it is possible to keep any authorized jury member to adjudicate on any matter of the jury, irrespective of the class he/she happens to represent.

2. Authority and Duties

The Jury sits as long as the event lasts and hears all protests relating to that event.

The jury must decide as soon as possible on all protests presented to it during the event.

402.02 - INTERESTED PARTIES

No member of a Jury who has taken part as a competitor or Official in the race concerning which a judgement is to be given or knows himself to have directly or indirectly an interest in one of the parties involved, may judge the protest.

However, a member of an International Jury shall not be disqualified even if one of the parties is from his/her NA.

403 - PROTEST PROCEDURES

403.01 - VALIDITY OF PROTESTS

Only a driver may protest against facts pertaining only to the races in which he/she takes part. ***In case of a blue card, each recipient may protest against the penalty.*** Joint protests signed by several drivers will not be considered.

All protests must be in writing - type written or hand written in printed characters in English.

It must state the reason for the protest and be accompanied by any relevant documents that shall provide evidence within the given time and any protest fee as stipulated by the Race Organiser.

All protests must be signed by the protester.

The protest must be handed to the Race Secretariat who must, in the presence of the protester, record the time of receipt.

Any costs involved in verification are to be borne by the losing party.

A written protest can be withdrawn by the protester ; he/she then loses the protest fee.

403.02 - PROTEST FEE

The amount of the Protest fee must be decided by the National Authorities and it must be published in the advance programme. The maximum amount for a Protest fee will be decided by the UIM General Assembly. It will be 150 € or an equivalent sum in the local currency.

403.03 - RIGHT OF PROTEST

A protest can be lodged against the posted provisional results or against any decision made by the Race Committee or against one or several competitors.

In the event of one driver protesting against a penalty imposed on him and/ or one or more drivers protesting simultaneously against this competitor due to the same incident, the jury will have only one meeting with all concerned drivers being party of this protest procedure. The same applies if several drivers protest against the same jury decision.

A protest can only be lodged on a subject which directly concerns the protester himself. A protest which complies with these rules cannot be refused by the Jury.

Only one follow-up-protest is allowed against a jury decision following an initial protest that was lodged according to the first paragraph of this rule. All parties of the initial protest will automatically become party to this follow-up-protest and must be invited to the hearing. No protest is permitted against a jury decision about a follow-up-protest. Such jury decision can only be contested by appeal.

403.04 - TIME OF LODGING A PROTEST/ PROTEST PERIOD

A protest regarding the qualification of a boat, a motor, or a driver must be made before the first drivers briefing. Starting in a race is considered as acceptance of the conditions and the eligibility of the other competitors. The only exception to the above is when the protester can prove the facts were not given to him before the drivers briefing, then a protest can be lodged up to one hour after the posting of the results.

Any other protest must be lodged within one hour of the first results being posted with the following exceptions:

A protest of a driver (driver "A") against another driver (driver "B") can be lodged within 30 minutes after the posting of the protest form according to rule 404.03 if driver "B" has been penalized and himself protested against this penalty. Without lodging such a protest driver "A" shall not be entitled to appeal against the jury decision.

A protest against any other decision, posted after the posting of the first results can be lodged within one hour after the posting of this decision.

403.05 - JUDGEMENT

Decisions by the Jury shall be reached by simple majority of votes. In the case of equal votes, the Chairman's vote will be the casting vote.

In the event of a protest, penalties may be agreed, rejected or changed by the Jury.

If a protest is upheld by the Jury, the fee must be returned to the protester.

Any judgement pronounced by the Jury stays in effect until altered by the Appeal Board.

403.06 - NOTIFICATION OF DECISION

All decisions by any jury, the minutes of the meeting and the justification of the decision must be notified to the concerned parties in writing, including their right of appeal. A copy of the Jury decision must be posted in the same way as the results. The time of posting must be noted on this copy.

403.07 - AVAILABILITY OF DOCUMENTS

All documents relevant to any decision by the Jury must be filed with the organising N.A. and held available for a higher authority until the time limit for an appeal has expired.

404 - HEARING OF THE PROTEST

404.01 - RIGHT TO A HEARING

Any person being party to a protest or being charged for an offence against the rules shall have the right to be heard before the Jury in order to defend himself.

404.02 - WITNESSES AND EVIDENCE

It is the responsibility of the parties involved in a protest to ensure that witnesses appearing on their behalf together with any other evidence are present and the Chairman of the Race Jury at his/her sole discretion may take their availability into account when determining the time of the hearing.

Any costs incurred by the appearance of witnesses shall be borne by the respective parties unless decided otherwise by the Jury.

404.03 - THE HEARING PROCEDURE

The following procedure must be followed in all hearings unless otherwise stated elsewhere in these rules:

- A copy of the protest must be posted in the same way as the results. The time of posting must be noted on this copy.
- Together with a copy of the protest, the Jury must give written notice to all parties of where and when the hearing will take place. Reasonable time shall be allowed to the parties for the preparation to the hearing.
- If any party duly notified, fails to appear without giving an acceptable reason, judgement can be rendered by default i.e., the missing party shall lose the protest.
- Written minutes must be taken. Using of secretary for taking minutes for Jury Chairman is allowed. Secretary has no right to vote (or act as interpreter).
- All parties to the case are entitled to be present and to hear and question all evidence at the hearing up to the time the Jury makes its decision.
- If the jury meeting involves a junior (less than 18 years of age) then he/she must be accompanied throughout the meeting by an adult (parent/guardian).
- The protest shall be read out to the parties.
- A party to the hearing who believes that a member of the Jury is an “interested party” or otherwise not suitable to decide upon the protest shall object at the beginning of the hearing and before he/she states his/her own case. Failing to do so will result in acceptance of the relevant jury member unless the party can prove that the circumstances and facts resulting in the ineligibility of the jury member came to his/her knowledge only after this moment. In this case the party has to object immediately after having obtained the relevant information.
- Then the Jury shall decide whether all formal requirements of the protest are fulfilled (403.01 – 403.04 and possible additional rules of the relevant class). Failures shall lead to the protest being void. The parties shall be given the opportunity to give statements if failures are found and before a final decision on the formal legality of the protest is taken.
- The parties shall be invited to state their cases. The parties may call witnesses. Each witness, after having given his/her account of the case, may be questioned by all parties and by the members of the Jury. Any other evidence available may be presented.
- Any member of the Jury who is familiar with the case may give his/her evidence
- The parties shall be entitled to question each other and any member of the Jury who may have given evidence.
- The witnesses shall withdraw and the parties shall be invited to make a final statement of their cases.
- The Jury may recall any party, previous witness or new witness and call on any other evidence to verify the facts.
- The parties must be present during the whole of the recall and must be given the opportunity to question any new evidence after which they may re-make their final statements.
- After all evidence has been assessed the situation with the protest may be discussed. The hearing will then be closed and the Jury shall debate the case and take a decision in a closed meeting and no other person but the jury members have a right to be present.
- For further procedure see rules 403.05-403.07.

405 - THE APPEALS PROCEDURE

Unless stipulated differently below, the rules for the protest procedure shall apply to the appeals procedure as well. With reference to the 405 appeals procedures, any time limits which end on a Saturday or Sunday shall end on the following Monday. If the Appellant misses any time limit the appeal will be rejected as void.

The UIM will decide on Appeals arising from International titled events according to the "UIM International Court of Appeal" rules unless differently laid out in these 405 rules.

The UIM will not decide on Appeals arising at UIM IOR. Such appeals will be handled by the organizing National Authority according to applicable national rules for Appeals.

405.01 – UIM INTERNATIONAL COURT OF APPEAL (ICA)

The ICA sits whenever the Chairman calls a meeting.

405.02 - INTERESTED PARTIES

No interested party shall be member of the ICA as set forth in the ICA rules.

405.03 - RIGHT OF APPEAL

A decision by a Jury may be appealed by the parties involved in the Jury meeting when they consider that an injustice has been made against them and/or fresh evidence has been made available that may alter the decision of the Jury.

A driver can also appeal a penalty, imposed against him/her without the prior lodging of a protest, but only if this was not possible, because the race Jury has been dismissed before or within the protest period

405.04 - NOTICE OF INTENTION TO APPEAL

The intention to appeal must be notified in writing to the Secretariat of the UIM by the interested party within four days of the day following the Jury decision or in the case of a decision against which a driver can appeal without the prior lodging of a protest within four days of the day following the notification of this decision to the NA of the driver or if earlier to the driver concerned.

405.05 - TIME LIMIT

All appeal documents and fees must be received within ten days from the date when the notice to appeal was received by the UIM Secretariat.

405.06 - LODGING OF AN APPEAL

The appeal must be sent by telefax, letter or Email and it must be signed by the appellant. The reasons for the appeal must be stated.

Address, telephone, e-mail and/or fax should be clearly mentioned on the appeal, so that the UIM can send any correspondence directly to the driver with copy to relevant N.A.

405.07 - NOTIFICATION OF THE PARTIES OF THE APPEAL

The UIM Secretariat must within two days from receiving the appeal, notify by facsimile or letter the other parties that an appeal has been lodged and that they may send a rejoinder.

Such rejoinders must be received within ten days from receiving this notification.

405.08 - TIME LIMIT FOR DECISIONS ON APPEALS

All appeals must be determined no later than forty-five days after the date when the appeal documents and fees were received by the UIM Secretariat.

405.09 - UIM INTERNATIONAL COURT OF APPEAL (ICA) DECISIONS

The ICA takes its own decision based on every information available. The decision of the Jury may be upheld, changed or not upheld. The decision of the ICA is final.

405.10- COSTS

The appeal fee is 2000 €. In addition, the driver has to pay 2000 € to the UIM for possible costs of the ICA (IT meeting arrangements, telephone, laboratory, experts and other costs of the appeal procedure).

If the appellant requests the appeal procedure to be conducted in physical presence of the persons involved, related extra costs in excess of the deposit of 2000 € shall be at the charge of the appellant.

If during the procedure further costs arise, the Appellant has to deposit the missing amount accordingly within 14 days from notification.

The driver who appeals has to pay for the meeting costs anyway if the appeal is upheld or not. If the costs of the appeal committee are less than defined above then the difference will be paid back to the driver.

The appeal fee will be refunded if the appeal is upheld.

In case driver appeals because the race Jury has been dismissed before or within the protest period (405.03), appeal fee and deposit for handling cost is 50% from defined above in this rule.

If the original decision is changed by the ICA (405.09), it can decide to refund a percentage of the appeal fee if appropriate.

If there is an infringement of rules 405.04 or 405.05, the Chairman of the ICA can decide that the appeal is not considered valid since the deadlines were not respected. In this case 50 % of the received appeal fee will be reimbursed to the appellant.

Further appeal fees or deposits as foreseen in the ICA rules do not apply.

406 - PENALTIES

406.01 - GENERAL

Any proven breach of applicable Rules may be penalised.

If the rules do not determine a special penalty for the relevant breach, the penalty to be given has to be proportional to the seriousness of the breach. The proportionality is at the discretion of the decision maker.

The UIM Executive Committee or the relevant National Authority shall only impose penalties, when they deem the relevant infringement to be so serious, that it has to be penalized although the deadlines for penalizing or lodging a protest have already expired. After the expiry of the aforementioned deadlines, a penalty for an ordinary breach of the rules shall in general not be imposed.

The Race Jury or the Appeal Board following a protest or an appeal can (only) impose penalties, which can be imposed by the OOD.

406.02 - DEADLINES FOR PENALIZING

The first posted results are provisional for one hour. The National Authority and/or the UIM Executive Committee can only impose penalties within 3 month from the day, the infringement occurred.

These deadlines are not valid for penalties imposed by the OOD for the reason of post race scrutineering and under the condition that this is stated on the results sheet.

In this case the results will remain provisional until one hour after the finalization of the post race scrutineering.

The date and time of finalization of the post race scrutineering must be recorded by the UIM Technical Commissioner or other technical scrutinizer in charge.

If the post race scrutineering can not be finalized until the end of the event and the OOD has already left the race site the penalty has to be imposed as soon as possible after the receipt of the scrutineering results by the OOD.

406.03 - UNACCEPTABLE BEHAVIOUR

In order to protect the interests of the sporting community, the following actions may also be penalised by the OOD, by the UIM Executive Committee or by the NA of the Licence Holder.

- any deliberate act taken to gain unfair advantage.
- any false act made or statement given with the intention of suppressing facts required for the proper conduct of the race.
- any attempt to bribe or the taking of a bribe.
- any abusive or unsportsmanlike behaviour.

406.04 - REPRIMAND

A Reprimand is a notice of disapproval of an unacceptable action. It must be recorded by the Race Secretariat. A reprimand must be witnessed. A reprimand automatically constitutes warning that if the offence recurs, a heavier penalty will be given. A Reprimand is valid for 12 month. A reprimand can be given by the OOD, or the National Authority of the Licence Holder.

406.05 - YELLOW/RED/BLUE CARDS

A yellow or red card may be given by the O.O.D./ UIM Race Director or UIM Commissioner.

A yellow or red card will be confirmed on UIM form which will be posted with the results and if it is confirmed it must be included in the commissioners report.

The driver has one hour from the posting of the penalty to protest (rule 403). If the protest is not upheld, he/she can make an appeal (rule 405).

All yellow/red cards received in all UIM disciplines and classes count towards the drivers CV and shall be accumulated.

Yellow/red cards can be given for bad behaviour on the water including :

- up to two yellow cards at a time for dangerous driving ;
- one red card for extreme blatant dangerous driving.

A driver who receives a red card is immediately disqualified from that event (300.01).

Receiving a third yellow card equals to a red card and carries the same penalties/actions.

A driver with a red card shall lose the right to take part in any UIM activities on the water for two months.

In addition, during the two years following the receipt of the card, he/she is not eligible for the first UIM titled race in the discipline or class in which he/she received the card.

Further penalties may be applied on a national level by the driver's NA.

All yellow cards will remain valid for the four UIM events (any UIM sanctioned races, titled or not) in which he/she

competes following the date on which the last yellow card was delivered or 36 calendar months from this date.

Yellow/red cards must be notified to the UIM and the drivers' National Authority within three days of completion of the event.

The UIM will notify all National Authorities when a driver has a red card or and is therefore suspended from international competition.

To be applied to all people in the paddock and to UIM competitors also out of competition:

A blue card can be given by the UIM commissioner/ OOD/ UIM Race Director for any offensive, unsportsman, abusive etc, behavior during an event.-Two blue cards may be given for blatant and unlawful misconduct.

Blue card(s) can also be given by the relevant UIM Commission or Committee, by the UIM Executive Committee or by the NA of the competitor for any offensive, unsportsmanlike, abusive and herby unlawful behavior committed in the media or in any other way vis a vis the public and in relation to UIM, UIM officials, promoters, local organizers.

A blue card will remain valid for one year from the date of issue.

A second blue card leads to disqualification (if issued against a driver) from all results obtained at the event where the incident occurred. It also leads to suspension from the rest of the event and from all UIM titled races in all disciplines or classes as a driver or team member for the next 4 weeks. If the second blue card is given for out of competition activity the penalty will be prolonged suspension according to rule 406.08 for one future event, designated by the same body that issued the second blue card.

406.06 - DISQUALIFICATION

Disqualification deletes a competitor from the results of the heat or race where the offence occurred.

Disqualification is done by the OOD.

406.07 - TEMPORARY SUSPENSION

Temporary suspension suspends a competitor, a competitor together with crew, a crew member, or an Official from all or part of an event. Temporary Suspension may be given for serious indiscipline.

Temporary Suspension will be imposed by the OOD.

406.08 - PROLONGED SUSPENSION

Prolonged suspension can be imposed on a competitor, an Official or an organisation for deliberate fraud, repeated or very serious indiscipline or very serious misconduct. Prolonged Suspension can be imposed only by the NA of the licence holder or organisation, or by the UIM Executive Committee. A Prolonged Suspension is always international. The NA must immediately inform the UIM of a Prolonged Suspension and the UIM must inform all other NAís.

406.09 - EXCLUSION

Exclusion means a permanent loss of all rights to take part in any activities falling under the UIM and its affiliated organisations. A person or an organisation who has committed a moral or sporting offence of extreme gravity is liable to be excluded. A sentence of exclusion can be pronounced only by the NA of the licence holder or organisation, or by the UIM Executive Committee. Exclusion is always International. The NA must immediately inform the UIM when it has imposed a sentence of Exclusion and the UIM must inform all other NAís. In the case of suspension, prolonged suspension or exclusion, all National Authorities and therefore their affiliated clubs bind themselves to respect the decision and apply it in their own country.

407 - PRIORITY OF THESE RULES

The course of the UIM has to be exhausted, before the dispute can be brought before civil court.

408- POWERBOAT PROTEST FORM

PART A is for you, the driver, to complete and hand in within the specified time limit.

PART B is for you, the driver, to complete and give to the Protest Committee Chairman at the beginning of the Protest Meeting.

PART C is for the Protest Committee to complete.

PART A SECTION 1

NAME OF EVENT: _____ DATE OF RACE OR HEAT: _____

HEAT _____ NUMBER: _____

CLASS: _____

SECTION 2

YOUR NAME (PROTESTOR): _____

YOUR BOAT NUMBER: _____ BOAT NAME: _____

SECTION 3

I (the Protestor) am protesting against: (tick ✓ as appropriate)

To seek redress from the Race Organising Committee for actions or omissions.

Another driver, name: _____ Boat No: _____

The Results as posted

SECTION 4

Which rule has been infringed _____

Time of incident: _____

On which lap was the incident _____

Where was the incident _____

SECTION 5

Your signature _____

Time of signature _____

SECTION 6

You must see this section completed by the official receiving this Protest:

Name of official: _____

Time Protest received: _____

PART B SECTION 7

Either explain incident with another driver; in writing and by drawing; Or

explain your reason for Protesting against the Race Committee:

Part B cont/d.....

409 - ARBITRATION

409.01 - GENERAL

A party of the appeal procedure has the right to ask for a final arbitration at the CAS (Court of Arbitration for Sport). The commencement of the arbitration procedure requires the acceptance of the mandate by the CAS. In the event that the CAS refuses to accept the mandate for arbitration the decision of the Appeal Board remains final. The CAS procedure must abide by the following rules.

409.02 - PARTIES OF THE ARBITRATION PROCEDURE

- a. The UIM will be party of the arbitration procedure and will be represented by the chairman of the Appeal Board.
- b. Any other party of the appeal procedure shall be notified of the arbitration procedure and may join the arbitration procedure as party by written declaration to the UIM office or directly to the CAS.

409.03 - DEADLINES FOR ARBITRATION

The intention to ask for arbitration must be notified in writing to the secretariat of the UIM by the interested party within 7 days of the day following the notification of the appeal decision.

A written justification for the claim for arbitration must be received by the Secretariat of the UIM within 14 days from the day the intention to ask for arbitration was received by the UIM secretariat.

The notification and the justification must be signed by the party.

409.04 - FEE AND COSTS

The UIM arbitration fee is 1.525,00 EUR. The CAS may decide to refund/ partly refund this fee according to rule 405.10.

Regardless of the final outcome of the arbitration procedure all costs arising out from the arbitration by the CAS (e.g., invoices from the CAS or from experts mandated by or on the initiative of the CAS, travel, accommodation and communication costs of the UIM representative or similar) are borne by the party who asks for arbitration unless differently foreseen below.

This party must deposit an amount that covers all such possible costs no later than 14 days after being notified of the amount. The Secretary General has to determine this amount after consultation with the CAS and taking into consideration an amount of 2.290,00 EUR for possible costs arising to the UIM. The deposit has to be paid by bank transfer the UIM or directly to the CAS as determined by the UIM Secretary General. If during the procedure further costs arise, the party who asks for arbitration has to deposit the missing amount accordingly within 14 days from notification.

A party according to rule 409.02. b. bears the costs that arise from the performance of its rights as party of the arbitration procedure including but not limited to travel and accommodation costs, consulting fees and similar.

409.05 - FURTHER PROCEDURE

The CAS will be mandated by the parties involved but only through the UIM secretariat. The UIM will assist the party by drafting and transferring the mandate to the CAS. The UIM must not transfer any mandate to the CAS unless the arbitration documents and fees according to rules 409.03 and 409.04 will be received in due time.

If the interested party misses any deadline, this party loses the procedure and the decision of the Appeal Board will be automatically upheld. The UIM secretariat in this case will not submit the mandate to the CAS or withdraw any mandate that might have been submitted. In this case the interested party has to pay 50% of the arbitration fee and any costs according to rule 409.04.

The further procedure shall be determined by the CAS.

409.06

The decision of the CAS will be final and it shall not be subject to any further jurisdiction.

GROUP 500 TECHNICAL RULES

500.01 - CLASSIFICATION OF PLEASURE CRAFT

Boats and vessels, as defined by Internationally recognised standards for Recreational craft.

500.02

Only the craft whose technical characteristics are registered by and defined as a Recreational Craft by one of the following International Certification Bodies and registered by one of the following Technical Institutions should be considered pleasure craft:

In addition, and only for the purposes of these rules, The UIM NA may issue a certificate to a craft built before 1st January 2000 which meets general pleasure boat standards. For a UIM Titled event the PN Commission must be made aware of NA certificate and authorize the use of this craft."

Europe –CE/ISO Standards (Recreational Craft Directive)

USA – USCG or State Certified.

Australia/New Zealand – Australia transport Council/Maritime New Zealand

Japan – Japan Craft Inspection Organisations

Technical Institutions:

- RINA (Italy);
- C.N.S.N.P. (France) ;
- AMERICAN BUREAU OF SHIPPING (USA);
- DET NORSKE VERITAS (Norway);
- LLOYD'S REGISTER OF SHIPPING (United Kingdom);
- NIPPON KYOKAI JAPAN (Japan) ;.
- GERMANISCHER LLOYD (Germany).

Other recognised similar bodies and institutes can be included to this list as required.

500.02.01 MEASUREMENT CERTIFICATE / LOGBOOK

A boat is not allowed to take part in a local, National or International race without a Measurement Certificate, issued by a National Authority, made up in the native language and in English according to the official UIM Measurement Certificate with logbook.

The Measurement Certificate/logbook shall follow the powerboat in all its racing activities. This is to get the whole racing history of the boat.

The Measurement Certificate/logbook shall be updated at any change of year, rules, engine, owner or class.

Each National Authority stipulates the cost of Measurement and the duration of the validity of the Certificate.

500.03 - CRAFT HOMOLOGATION

All craft shall bear a certificate or Hull plate issued by official recognised Bodies (see 500.02) which meet relevant Laws concerning pleasure navigation in their area of operation.

The certificate / Hull Plate must contain: Manufacturers Name, Boat Design Category, Maximum Person Capacity, Maximum weight allowed, Maximum Engine HP/KW.

A Builders plaque attached to the hull is required containing the information as defined by the certification Body and the builders serial number relevant to the boat.

In competitions taking place at sea over six miles from the shore only pleasure boats registered and certified for this type of navigation are permitted.

500.04 - CRAFT DIMENSIONS

All boats must be Monohull.

The dimensions of the hull – length, and weight- will be verified by the technical officers before each race.

Only solid fixed ballast is permitted. The use of water ballast is strictly prohibited. Failure to comply with this rule will result in disqualification.

If boats have devices for loading or unloading water ballast, these devices have to be out of function, closed and sealed for the races. The technical official must check this before and immediately after each race.

LENGTH MEASUREMENT

The criteria of length measurements for the purpose of craft classification are illustrated below :

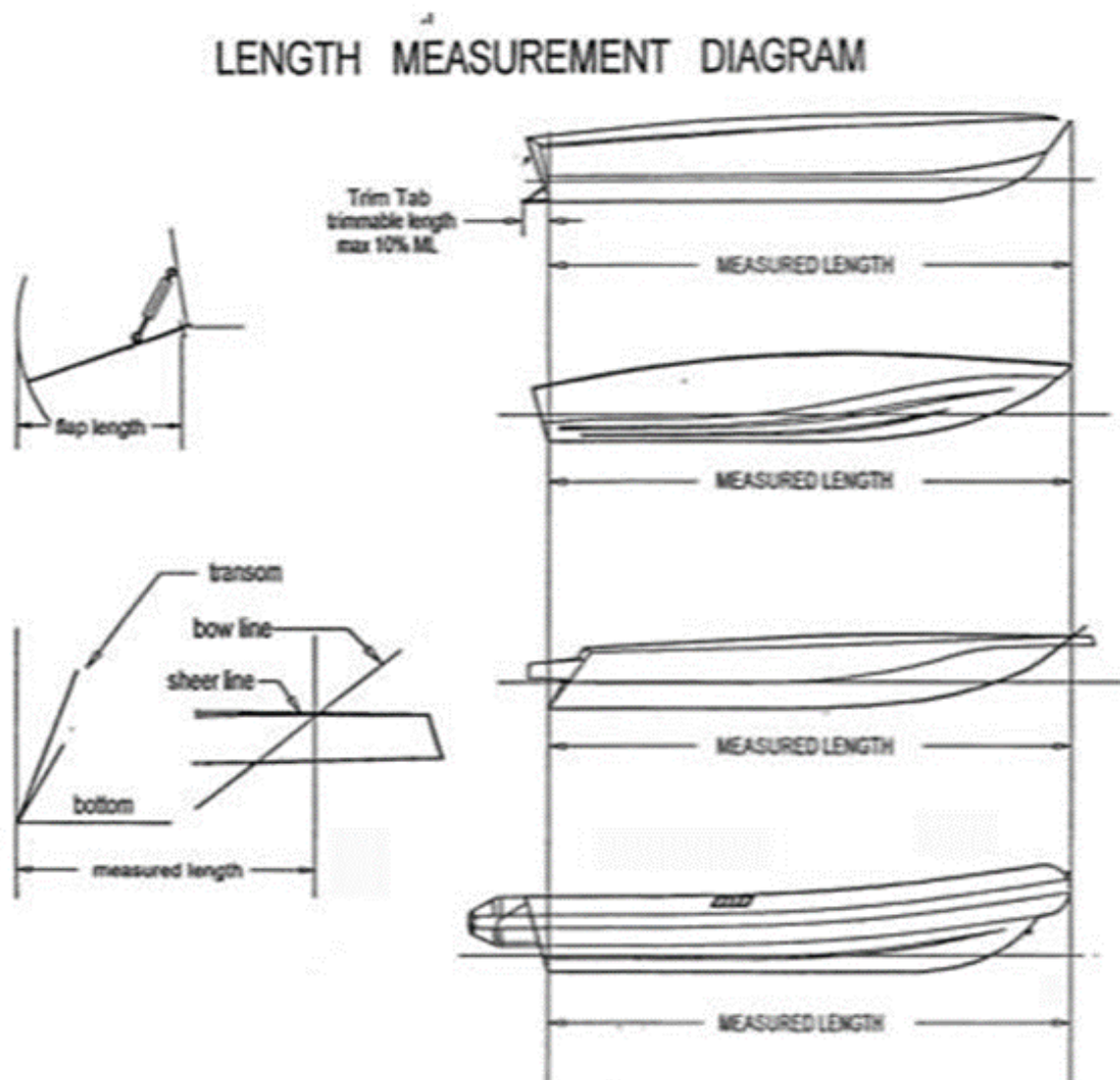

500.04.01 – MONOHULL DEFINITION

1. A monohull is a boat with one hull
2. A minimum distance of 80% of the "Measured Length" should, in the centerline be the deepest part of the hull.
3. Transverse sections should from the centreline, have positive angles up to the sections maximum beam, except in the following 2 cases.
 - (i) Each spray deflector may have a concave and/or negative angled surface with a horizontal width from the outside edge of the spray deflector in to the hull of no more than 8% of the hull's maximum chine beam (see Drawing)

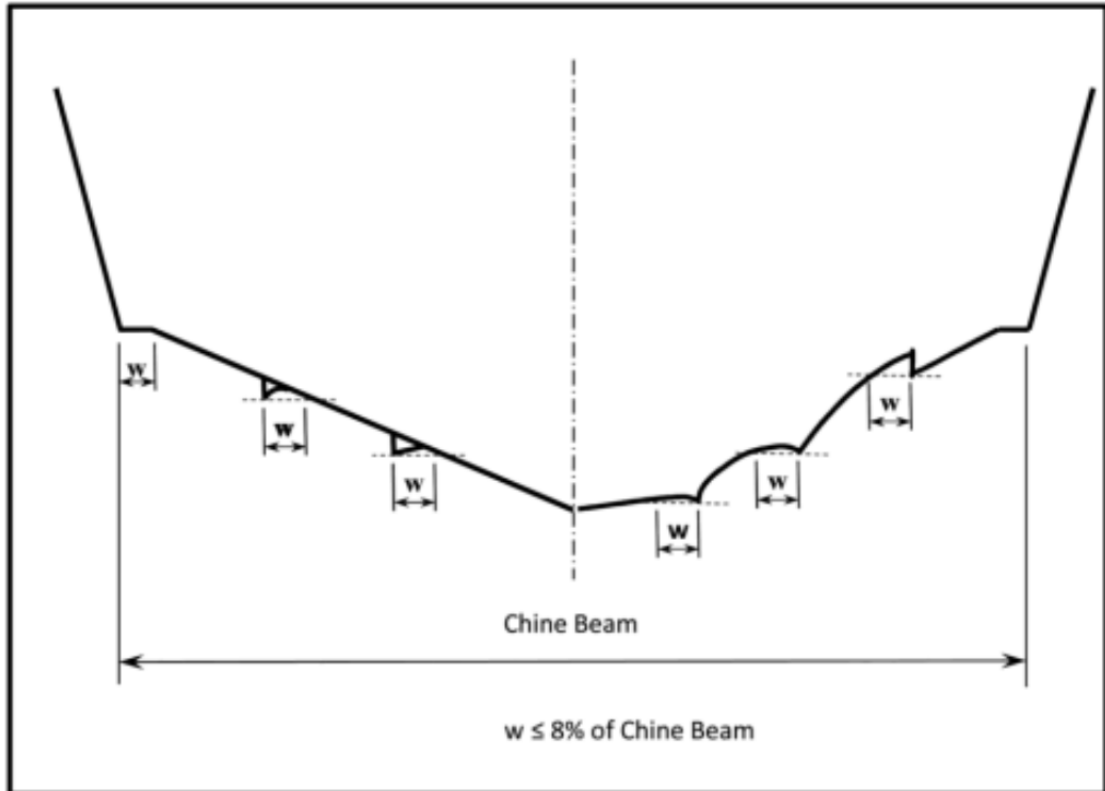

- (ii) Steps which are swept aft or forward may have a distance "S" of no more than 25% of the Measured length (see Drawing)

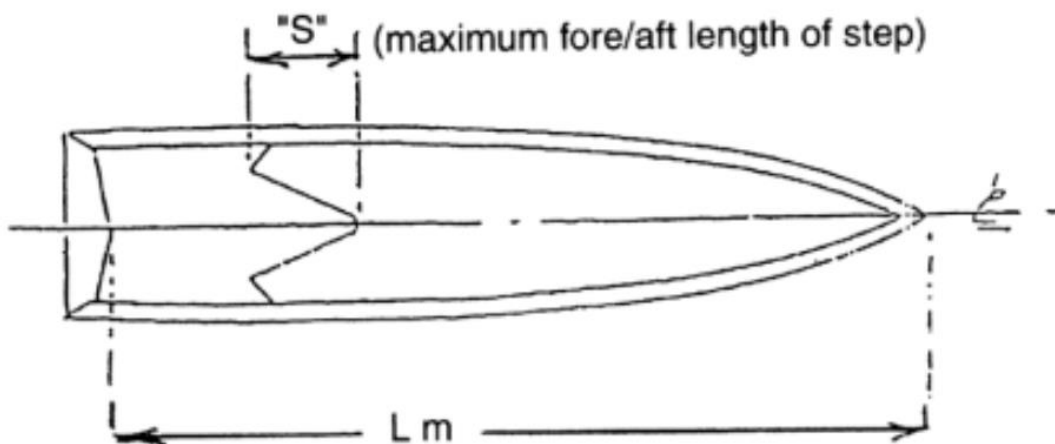

500.05 - ENGINES

Engines must have been available to purchase from the manufactures retail catalogue and remain unaltered from the original specification.

It is the responsibility of the competitor to provide technical specifications of their engine/s.

An inspection of the engines can be made after the competition is finished; if the engines are not in accordance with those stated in the official documentation the competitor will be disqualified.

500.06 - RACE NUMBERS

The competition number may be painted or a decal.

Minimum Measurements and characteristics:

- Placed on both sides of the Hull
- Numbers must be Black on a white background
- Number height 30 cm
- Number thickness 5 cm
- in case of a 3 digits number, the length of the surface must be modified consequently.
- Numbers should be placed on a vertical surface but where not possible on a slightly curved surface provided that the whole number is within 30° from the vertical position.
- On long distance offshore events, the number must also be displayed on the foredeck.

In exceptional circumstances at UIM Titled events, the UIM Commissioner may accept exceptions; his/her final decision being based on effectiveness and readability of the number.

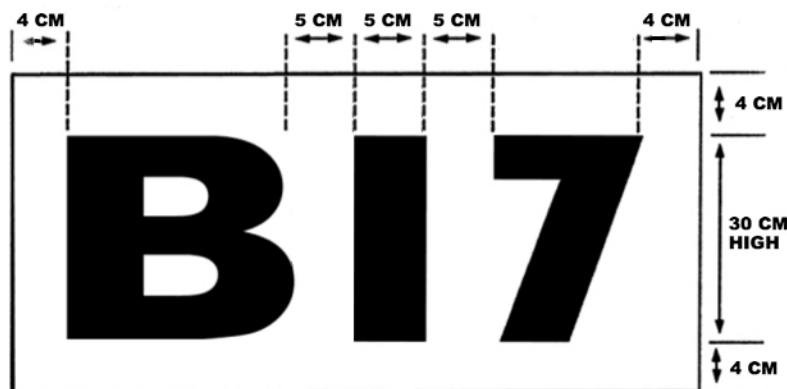

501 - REGULARITY COMPETITIONS

501.01 - DECLARED SPEED COMPETITIONS

Maximum speeds are established by the Organiser according to the engine power and/or cubic capacity.

The maximum speed must be declared in the advance-programme.

502 - ENDURANCE COMPETITIONS

502.01 - GENERAL

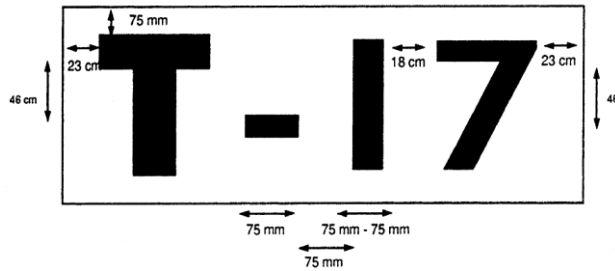

502.02 – GROUP “A” HISTORIC OFFSHORE CIRCUIT RACING (HOCR)

1. DEFINITION

- HOCR is multiple short lap powerboat racing consisting of several timed races at each event. Each race is a minimum of 25mins plus 1 Lap.
- HOCR is an affordable entry level form of powerboat racing which welcomes competitors of all ages. (HOCR 3 minimum age: Driver 16 / Navigator 16 / All other classes minimum age: Driver 18 / Navigator 16)
- Racing takes place near the shore which associated with challenging courses containing several turn marks which tax the driving and navigational skills of the crew.
- HOCR is a family friendly sport which engages spectators wherever it takes place.

2. CLASSES

The HOCR Series shall be sub-divided into Four single engine classes and one **single / twin** engine class. To identify which class a boat is to enter, the class calculator is to be used. Generally, this will be according to the engine manufacturer's specification as detailed below:

a) Engines

Class Cubic Capacity / hp

HOCR Super Sport Boats fitted with **single / Twin** Engines Max 500hp

HOCR Sport Boats Max 300hp

HOCR **F1** Max 199hp

HOCR **F2** Max 149hp

HOCR **F3** Max 100hp

Modifications to Engines

Any change or modification that is not allowed for in these rules will result in disqualification from the race.

- It is permitted to modify the engine cowling.
- It is recommended the engine rubber mounts be substituted with a solid alternative.
- Blueprinting of the powerhead to the manufacturer's or where available UIM homologation tolerances is permitted.
- Transom brackets may be reinforced.
- The fuel connector in the lower cover may be removed and the fuel hose from the fuel tank connected directly to the fuel pump.
- Modified production engines will be assumed as race engines and classed accordingly.
- 15 inch mid and / or low water pick-ups are permitted in HOCR Sport and Super Sport only.
- (Definition of modified) - Power enhancing modifications to the powerhead, Sandwich /adapter plates, exhaust tuners, ECU and electronic components. If any of these components have been modified from their original factory settings, configuration or tolerances 'Modified,' this must be declared in the logbook. Saddles, trim assembly and Engine Mounts are permitted modifications. If any openings have been cut or drilled in mid-section 'exhaust relief' must be selected in the logbook.)

b) Boats / Hull

i. Otherwise no specific boat design criteria, competitors must ensure That their engines fall within the boat hull manufactures specification

- ii. Boats requiring weight to meet Class requirements may only add a maximum of 10% of the boats original weight. This weight must be permanently bolted or fibreglassed inside the boat evenly divided between the transom and crew area. No fixed weight will be allowed forward of the front 1/3 of the boat.
- iii. Decks must be able to bear the weight of a 100 Kg person standing at any point
- iv. Towing cleats and eyes shall be of adequate construction and strength for the boat to be towed when waterlogged and shall be securely fixed to the main hull structure and not merely to the deck.
- v. Water deflector and Windscreen

It is recommended that Water deflector overdeck is fitted for classes HO CR 2 and above.
Must be well secured.

Must be of non-splintering material. The use of glass for windscreens is forbidden except where they are made from toughened glass.

Must be masked by rubber or plastic on any bare edges.

Must not be so designed That it would restrict the driver from being ejected.

All sharp edges must be adequately protected or removed.

vi. Buoyancy

It is a mandatory requirement That suitable buoyancy be installed and properly secured in the bow of the boat.

vii. Steering and Controls

All steering system components, control cables, linkages, quadrants and any fitting within the steering system must be in good condition, secure and fit for purpose.

Hydraulic steering must be fully operative, hoses and unions must be free of leaks and adequately protected.

Single push pull steering is not permitted.

It is highly recommended That Hydraulic steering is used in all classes.

HO CR F2 boats and above are to have a matched 1500psi Steering System. 1000psi high capacity side mount systems may be acceptable.

All control cables shall be in good working order, securely fastened and any lose ends taped over.

viii. Engine Cut Off

Engine cut-off device ("kill switch") for connection to both the driver and navigator is mandatory. An emergency override system or additional kill cord is to be stored inside the boat to allow the engine to be restarted if the driver is not in the boat. Co Pilots / navigators will be required to demonstrate their ability to restart the engine and drive the boat if required.

Kill cords must not exceed 120cm between driver and the connection to the boat.

The emergency cut-off device must be positioned so That when it operates, the connection cord and cap or clip will not catch or foul.

Kill Switches are to be connected to the driver at ALL times when the engine is running

Boats with a tandem set up are required to be fitted with a kill switch for both the Driver and Co-pilot / Navigator OR an audio/visual alarm which will activate in the event of the Co-pilot / Navigator being ejected from the boat.

ix. Throttle and Gear Controls

Foot throttles must be properly connected, work freely and must be in a position where it cannot be fouled. It must quickly return the engine to idling speed when released and have a secondary means of return in the event of failure

All craft must be able to be manoeuvred ahead and astern under power and have neutral capability with controls at the driver's position. Hand throttles are not permitted.

x. Seats

All boats must have a min of two seats of adequate strength and support and must be secure and unmoveable.

It is **STRONGLY RECOMMENDED** That seat backs are of sufficient height and width to support the back of the head (Note: - AS PER 2018 EGM This is Highly recommended)

An infill behind the front seats is permitted but in the case of tandem seating the infill must start behind the navigator / co-driver's seat. Infills must be at least 40mm below the top of the seat backs and must be securely fitted. Should an infill be removed or not fitted all pins and brackets must be removed from the hull/deck.

Where practical seat height should be such That each crew members shoulder should be level with the adjacent top side of the boat (see 2018 EGM Minutes).

xi. Fuel Tanks

All tanks shall be secure in all directions undamaged and not leak. Canopied craft are to have fuel tanks contained in sealed compartments from the hull and crew area to avoid leakage of liquid or vapour being released into the area being used by the crew. Fuel filling / fillers are to be outside of the crew compartments.

There shall be a clearly marked and easily accessible means of shutting the fuel supply off from the tank(s). Permanent metal tanks shall be earthed.

Fuel lines shall be leak and chafe resistant and run in a manner to avoid damage.

xii. Engine Mounting and Hazards

Mounting brackets and clamps must be secure and in a satisfactory condition and attached to the transom with at least four bolts each secured with locking nuts and must be to the satisfaction of the scrutineer.

The engine must be free of dangerous corrosion, oil or fuel leaks or excessive heating likely to be a fire hazard or a danger to any adjacent structure within the boat.

xiii. Batteries

A clearly marked battery isolation switch in the positive or negative supply line shall be fitted in an accessible position within the boat.

All batteries shall be mounted upon a secure and solid platform and secured with fittings sufficiently strong to withstand any anticipated shock or inertia encountered during a race. Batteries shall be free of corrosive leaks and well maintained to the satisfaction of the scrutineer.

xiv. Propeller Security

It is the responsibility of the competitor to ensure That the propeller or propellers are sound, particularly at the blade roots and are securely locked by the propeller nut(s).

When the boat is not in the water, the propeller shall be fitted with a suitable guard which is sufficient to prevent injury in the event of any physical contact by a person.

In the dry pits it is forbidden to start a motor with the propellers mounted.

After launching a boat, it is forbidden to start the motor(s) or the engine(s) with the boat elevated and the propeller(s) rotating.

xv. Steering Engine Well - Outboards

All holes cut into the bulkheads of the engine mounting structure for the purpose of passing control cables etc., must be watertight, as high as possible and above the level of the lowest point of the transom cut-out.

xvi. Bilge pumps and Bailing

There shall be at least one electric bilge pump fitted to the boat. The number and capacity of pumps installed shall be appropriate to the size of the boat. All bilge pumps shall be in proper working order and secured to the boat.

It is MANDATORY That in addition to the electric bilge pump a secondary means of bailing is available within the boat (e.g. Bailing bucket or manual bilge pump).

xvii. Towing Lines and Mooring Fenders

A suitable tow rope with a spring-loaded snap hook on one end is to be safely secured within the boat at all times whilst racing.

All towing lines and the towing point must be of adequate construction and strength for the boat to be towed when waterlogged.

Towing lines should be no longer than the length of the boat to prevent it fouling the prop should it become detached.

All boats shall carry adequate and suitable fenders and mooring lines for use when moored alongside another boat .

xviii. Damaged Boats - Logbooks

If during an event a boat is damaged so as to be deemed unfit to race, the Race Scrutineer will complete the relevant part of the logbook and give a copy to the competitor. The boats logbook will be sent to the relevant National Authority and only be reissued after the competitor provides proof from a competent person That the boat has been examined after repairs have been made and deemed fit to race. Ultimately it is the competitor's responsibility to ensure That a boat is fit to race. In addition, any recommendations made to a competitor about the condition of a boat will be noted on the logbook.

3. NOVICE CREW

- a) Any team with a crew member competing in his or her first 3 events (Classified as a Novice) may be required to display identification That they are a novice. Details of this will be given in advance if required. Novices entering in HOCR **F1** Class Boat will only be permitted at the discretion of the National Authority.
- b) These teams may need to be positioned furthest from the start boat during their first three races, this will be detailed in race instructions or at the drivers briefing.
- c) Novice Drivers and Co-drivers will be under periodic review to monitor their performance and where necessary may be required to undertake additional training.

502.03 - GROUP “B”

All recreational boats built in any EC countries, entering the above mentioned Championship must conform to ISO-CE regulations (Recreational Craft Directive) currently in force.

All Boats must carry a Builders CE Plate and HIN Code Visible on stern of the Boat.

All open boats must have their bow painted fluorescent Yellow at least 0.5m. The number of riding crew members must be written in black in at least 0.25 m high in the Yellow area.

All closed cockpit boats must have their bow painted fluorescent Orange at least 0.5m. The number of riding crew members must be written in black in at least 0.25 m high in the Orange area.

Minimum number of crew is 2.

The number of crew members must be the same in all heats. The driver must be the same in all heats. Other crew members can change during the event, but only those who are registered. A maximum of 3 crew members can be registered.

The throttle command has to automatically return to the neutral position when no pressure is exerted on it. The driver cannot accelerate with his/her hand. The driver can only accelerate with his/her foot. The co-driver can accelerate with his/her hand (throttle man).

The deck and engine compartment hatches of the craft must be able to support at any point the weight of a person as per CE certification.

Class Endurance Sport 450 (S) in open boats the water deflector (s) is mandatory.

In Class Endurance Sport 450 (S) the throttle man is recommended.

In addition, please refer to 502.03.05 - Categories and classes.

502.03.01 - ENGINE CAPACITY

Maximum capacity to be installed

Following on from CE/ISO (Recreational Craft Directive) and similar such regulation. Maximum engine capacity/HP is as specified in the CE certification document of the craft and as declared by the Hull manufacturer.

This information may also be included on the Builders Plate

"In addition, please refer to 502.03.05 - Categories and classes.

502.03.02 - RACE NUMBER

The race number shall be displayed on the topsides (port and starboard) of the hull within a dedicated area:

- The numbers on the topsides (port and starboard) shall be displayed on the forward half of the boat;
- Numbers and letter must be highlighted in black on a white background;
- The letter and number which identify the class shall be put in front of the race number;

The race number and its dedicated area shall have minimum dimensions as indicated below:

- Numbers and letter must have a thickness of no less than 50mm.

502.03.03 - GENERAL

Pleasure craft with engine capacities not less than 1000 cc. may participate in competitions of Endurance Group B.

If reported in the craft's CE certification or similar, the powering can be made of two identical and independent engines.

During race and practice each person aboard a boat must wear a life jacket which satisfies the “UIM Life Jacket Basic Manufacturing Specifications” located on the UIM website.

All boats must carry sufficient buoyancy in order to float the hull in the correct way and assist rescue crews in the event of a capsized. Checking the effectiveness of the flotation is the exclusive responsibility of the crew members.

The participation of boats certified/homologated as a unique specimen is not allowed at Class Promotion and Class Boat Production. The boat manufacturer must build a minimum of 5 similar units of the same model.

Minimum number of crew is 2 persons.

All crew members in cockpit boats must be restrained using a six-point harness and are also subject to a mandatory annual immersion test. A separate air supply for each crew member is also mandatory in cockpit boats and occupied seats must have head restraints.

502.03.04 – MOTORIZATION

For all engines, all drivers must have the “workshop manual” of the owner of the engine.

All engines must be classed as “low Emission Engines”

The stock steering means (steerage) can be substituted with a more suitable Race proven System. All the components must be suitable to the craft and built by specialized firms.

The documentation (original certification of the boat builder and/or original catalogues of the boat builder of the components) proving the suitability of all the parts composing the steering mean, must be shown on request of the Technical Commissioner.

It is not allowed the application to the boats of fixed additional structures; movable awnings are allowed.

The boats not fitted with exhaust gas gathered within the propeller diameter should have the level of sound emission according to the Law 2003/44/CE of the European parliament of 16/06/03.

Older engines can only be updated with current parts if these do not produce increased power or displacement.

All crew members must be attached via lanyard to a kill switch which stops engines if any crew member is being ejected from their normal race position.

502.03.05 - CATEGORIES AND CLASSES

All pleasure boats with LOA from 5.00 m. to 8.99 m. fully conforming to the Boat Certification issued by an appropriate Technical Body, stating the dimensions of the craft and the installed engine capacities, may belong to this category according to the following:

A. CLASS ENDURANCE PROMOTION 150 (P)

Class Endurance Promotion 150 is exclusively boats with Outboard motorization, strictly of stock production as supplied by the original manufacturer for use in recreational boating with the following further characteristics specified:

- Mono-engine as from catalogue of the manufacturer
- each boat must be certified for transportation of a minimum number of people, not less than 4 (four)
- boats built in only one sample and/or homologated as an only one sample are not allowed;
- Inside fittings are free;
- Weight with crew
- Max power : 150 hp;
- The number of cylinders is free.
- Minimum number of crew is 2.
- Engine Jack plate are allowed but must be disabled during competition. Maximum Engine height is as per diagram.
- The power-to-weight ratio is 6.5 kg/hp.

Eg. 150 Hp = 975 kg

Maximum engine height

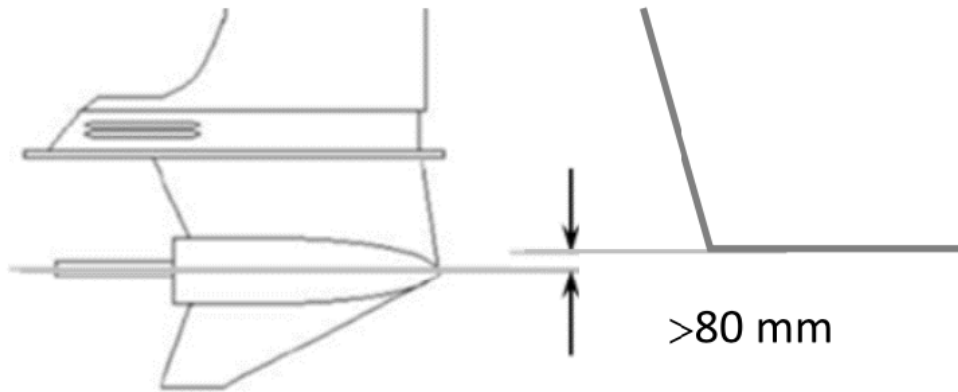

B. CLASS ENDURANCE BOAT PRODUCTION 300 (B)

Production pleasure craft, including fittings, produced in series and in compliance with the specifications of the boat builders, belong to this category.

Fittings are free.

Craft may be fitted with two engines if allowed on the approval certificate.

The gears-box must allow the following manoeuvres: forward, reverse, and idle with the engine running.

The participation of a boat certified/homologated as unique example is not allowed.

Minimum number of crew is 2.

Maximum allowed HP is 300HP.

The power-to-weight ratio for this class = 4.9 kg/hp

Each boat must be certified for transportation of a minimum number of people, not less than 4 (Four).

Minimum weight as per Power to Weight Ratio Table:

for example

Engine Power	Min. Weight included Crew
200 HP	980 Kg
250 HP	1225 Kg
300 Hp	1470 Kg

Engine Jack plate are allowed but must be disabled by a locking bolt during competition.

Engines are not allowed to be placed higher than having the centerline of the propeller shaft 60 mm below the extension of the keel line (on the most rearward step) then parallel to each other. If the keel line is not straight the end of the keel line and a point 50 cm forward shall be used to construct the keel line, see drawing:

Maximum engine height

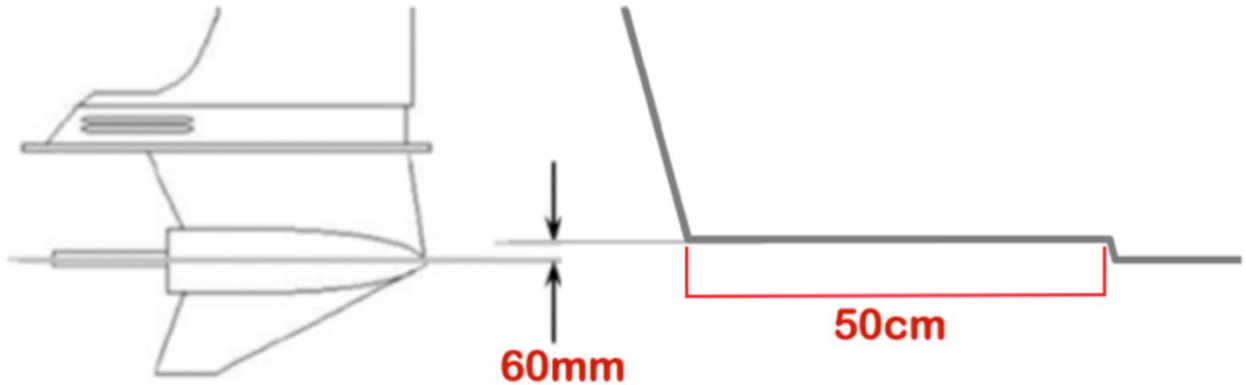

Technical attachment to the endurance competition rules.

Endurance Boat Production 300

Only stock outboard engines are allowed. Only the below mentioned modifications are allowed:

Only spare parts provided by the original engine manufacturer are permitted, so as provided by the catalogue and the engine exposure.

Cylinders can be bored up to the tolerances allowed by the engine manufacturer for that model of engine. Replacement parts must be original spare parts as available by the manufacturer.

Substitution with non-original parts is allowed only in the following particulars: spark plug, cables, pipes of spark plug, electric wires, nuts and bolts, water pipes, clips, anodes, oil filters, and propellers.

Any increase of power, coming from engine modification must not exceed the CE regulations (or regulations of non-EC countries) and the Kw/HP as mentioned on the plate of the boat identification;

Steering Bar mountings can be strengthened.

Stiffener and the anchorage between the legging and the steering bar in outboard engines are allowed.

Transmission modified for racing and surface drive are not allowed. The use of multi ratio speed change gear is not allowed.

Only non-modified stock gear cases and gear ratios originally fitted and sold with the engine are allowed, this includes CLE type gearboxes.

C. CLASS ENDURANCE SPORT 450 (S)

It includes all the general characteristics provided for tourism category except for what specified below:

The beam width of the hull is not restricted.

The units produced in series which have been modified in at least one of the following respects, belong to this category.

In the deck structures through removal parts, or by creation of a partial rigid bridge on prow.

By removal of fitting (furniture);

All engine model coming from the standard engine which have been modified in order to increase the performance for sporting activity, if included in the boat builder catalogue and reported in the craft approval certificate, are allowed in the Endurance Sport 450 category.

Any increase of power, coming from engine modification must not exceed the CE regulations (or regulations of non-EC countries) and the Kw/HP as mentioned on the plate of the boat identification.

In the Endurance Sport 450 category, it is allowed the participation of boats certified/homologated as a unique specimen.

The motorizations with any kind of supercharging* are not allowed in boats with outboard and inboard engines. The motorizations with any kind of supercharging* are allowed in boats with standard outboard engines.

(* supercharging : it is meant as a turbo-compressor or a volumetric compressor, it is not meant as a supercharging any fuel direct injection system that the engine manufacturer of the motor unit adopts in its first mounting).

Note

In the S450 category the transmission like racing (for CLE, or all lower gearcase with nose cone) and surface drive are allowed, but the use of multi ratio speed change gear is not allowed. The
foreseen classes are the following:

Minimum HP allowed is 325 HP and Maximum HP allowed 450HP.

Single or Twin engines allowed. Weight as per table.

- The power-to-weight ratio is 4.5 kg/hp.
- Weight with crew

Verification Weight

For the Endurance Sport 450 category, the allowed minimal weight for every boat is shown on the relevant power to weight Table.

Engine Power	Min Weight Included Crew
350 HP	1575 Kg
400 HP	1800 Kg
450 Hp	2025 Kg

The minimal weight is to be calculated at the end of the race, and it is referred to:

Boat Unit

Equipment on Board

Residual Fuel

Crew Ready for racing

Possible declared ballast.

The ballast can be only of solid type, must be strictly fixed to the structure of the boat ; fixing with ropes, elastic or other material easy to be removed is not admitted. The existence and the weight of the ballast must be declared and indicated on the TECHNICAL CARD by the Technical officer. At the end of any race, all the boats and drivers, must remain available for possible procedures of weight verification and relevant inspections.

During the weight verification procedure, the boat does not have to contain liquids different from the residual fuel and solid parts that are not equipment on board or declared ballast. The weight of the pilot will be the weight of his/her body together with the weight of his/her racing clothes. In case the minimal foreseen weight is not reached, it will be applied disqualification.

Technical attachment to the Endurance Sport 450 rules.

All modifications not clearly allowed are prohibited. Only outboard engines listed on the manufacturers catalogue are allowed. Only the below mentioned modifications are allowed:

Only spare parts provided by the original engine manufacturer are permitted, so as provided by the catalogue and the engine exposure.

Mounting Brackets can be reinforced or exchanged using original engine manufacturer parts. A gearbox can be modified to allow for Counter Rotation using original engine manufacturer parts. For the 2024 season, 15" Mid sections using non-original engine manufacturer parts are allowed.

Cylinders can be bored up to the tolerances allowed by the engine manufacturer for that model of engine. Replacement parts must be original spare parts as available by the manufacturer.

Substitution with non-original parts is allowed only in the following particulars: spark plug, cables, pipes of spark plug, electric wires, nuts and bolts, water pipes, clips, anodes, oil filters, and propellers.

Any increase of power, coming from engine modification must not exceed the CE regulations (or regulations of non-EC countries) and the Kw/HP as mentioned on the plate of the boat identification;

It is not allowed any kind of additive : liquid, solid, gaseous, performance increasing or anti-detonating as foreseen by the UIM rules.

502.03.06 - RACE PROCEDURES AND RACE COURSE

Race start and finish procedures will be detailed in the Race Instructions and during the pilots' briefings. An Endurance Group B race shall be a minimum distance of 38 nautical miles. A race lap cannot be less than 3 nautical miles unless required for a Bad weather course.

During the start lap, the minimum distance from the start line to the first turn mark (buoy) shall be minimum 1 nautical mile.

The official practice will be made on the same circuit used for the race.

There must be a minimum of one nautical mile visibility over the whole race course and there must be no forecast or other reason to believe that there will be any less visibility on any part of the course or its vicinity throughout the expected duration of the race.

From the wet pits:

- a) The Start Boat will communicate via radio to confirm departure from the Wet Pits. Yellow and green flag will be raised. Full details will be provided at Drivers' Briefing.
- b) All race boats are to follow the Start Boat to the muster area in the agreed position order as briefed at the drivers' briefing. No race boat may proceed ahead of the start boat.
- c) Where possible, a parade lap, around the course to the muster area will be included. Once in the muster area, the flags will be lowered.

From the muster area:

1. The muster area will be defined either in the race instructions or explained at the Drivers' briefing.
2. Once all race boats are milling in the muster area, two minutes before the start of the race, the start boat will raise and continue to display a 'Yellow Flag'.
3. The boats must proceed to line upside by side.
4. The start boat will then proceed across in front of the fleet and begin its run towards the startline.
5. All Racing Boat must keep in line, keep a safe distance from the nearest boats and 30m behind the start boat until the green flag is raised.
6. The start boat will ensure that all boats are in a satisfactory line and at a satisfactory speed (on the plane) before the green flag is raised.
7. Race start is indicated by simultaneously lowering the yellow flag and raising the green flag.
8. An aborted start is indicated by the lowering of the yellow flag and the raising of the red flag.
9. When a start is aborted, all race boats must come off the plane and return to the muster area to await further instructions.

Start Procedure under Yellow Flag

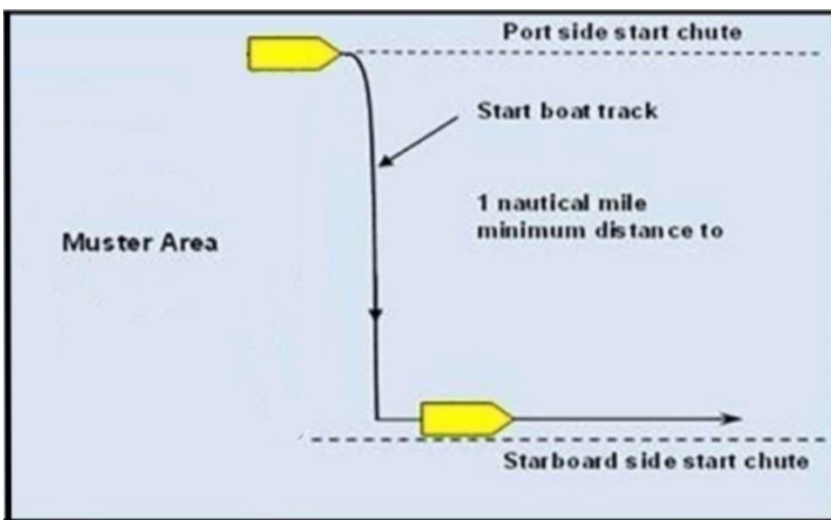

Start Procedure to Green Flag.

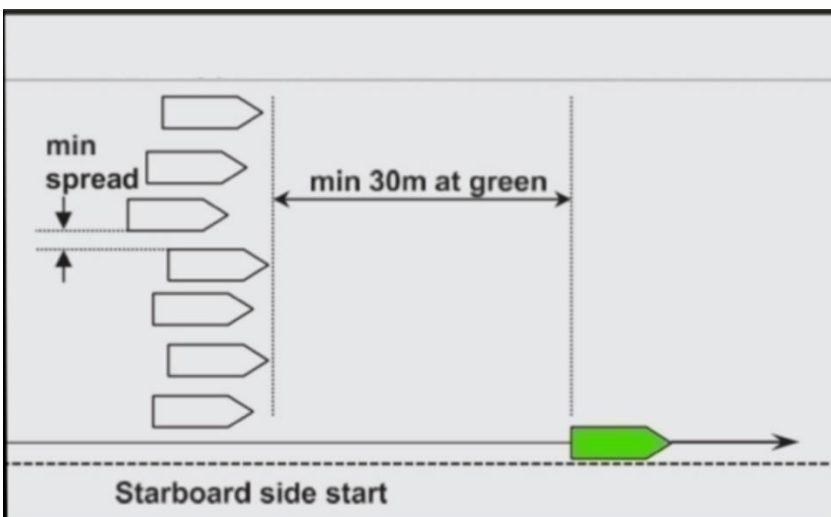

502.03.07 - CONTINENTAL AND WORLD CHAMPIONSHIP SPORTS RULES

502.03.07.01 - World and Continental Championship Racing Format and Titles

The UIM Continental or World Championship Endurance Group B will be composed of at least one event / Round per season. The titles 'World Champion' and 'Continental Champion' shall be awarded to the driver(s) from each Endurance Group B class, whose boat achieves the highest points score over the course of the Championship.

Each event will take place over 3 days, from Friday to Sunday.

- a) In case of one single event /Round counting for the respective championship, a Continental Championship shall be composed of a minimum of 2 races (1 long and 1 shorter race) and a World Championship shall be composed of a minimum of 3 races (1 long and 2 shorter races).

If in case of force majeure it is not possible to run all the races, the championship will be valid with one race run.

- b) In case of a Continental or World Championship with more than one event/Round counting for the Championships, each Round shall be composed of 2 races and at least two practice sessions, for each class, for as well the Continental Championship as for the World Championship. Championship points shall be awarded for both races. The races will be consisting in one long race and one short race counting for the Round. In case of force majeure, the OOD and UIM Sport Commissioner can decide otherwise.

A Continental Championship or World Championship can have maximum 3 events or Rounds counting towards the championship.

A National Authority can be allocated two rounds of a Championship, provided the maximum number has not been reached by requests of other NA's.

A UIM Commissioner and a UIM Technical Commissioner are required at each event. Each Round will be a 3-day event with at least on:

- 1) Friday: registration and technical scrutineering
- 2) Saturday: main drivers' briefing + free practice + race 1
- 3) Sunday : free practice + race 2 + prize giving ceremony

In case of a one single event counting for WC which requires 3 races, there will be a supplementary short race on either Saturday or Sunday

The interval between the end of a race and the start of the next one should be at least three hours.

There should be a minimum of one hour between the end of practice and the start of a race.

In case of inclement weather or other factors concerning safety, different event formats or race lengths may be decided upon by the OOD, UIM Sports Commissioner and the Safety Officer.

It is recommended that boats and all racing equipment (including racing gear of the driver) will be in the dry pits by Friday morning before the start of the scrutineering.

In any case, Boats must be in the dry pits on Friday by 15.00 pm at the latest, for technical scrutineering.

In case of equal points at the end of an event, the winner shall be the highest placed boat from the race run over the longest distance during the event.

502.03.07.02 - UIM National Authority International License & authorization to race abroad

All drivers must be in possession of a valid international license issued by their National Authority member of UIM for UIM sanctioned international events: UIM World Championship events, UIM Continental Championship events and UIM International Ordinary Races.

If a pilot has no national authority member of the UIM, the pilot can be licensed by another UIM national authority member.

Besides their International license, pilots must be in possession of a written authorization from their National Authority to race abroad and be able to show this to the race secretary during race registration.

Pilots with closed cockpit boats also have to present their immersion test certificate during race registration

502.03.07.03 - Minimum age

The minimum age for the driver of a boat is 18 years and for a navigator 16 years. All age regulations apply at the date of the race.

All persons under 18 years will be requested to submit a written consent of their parent or guardian to their participation in a race and confirmation of their acceptance of the rules governing the races.

Teams are responsible for the behaviour of all members and crew.

502.03.07.04 - Drivers' briefing

At each event, there will be a main drivers' briefing organized on the day of the first scheduled race of the event.

It is mandatory for all drivers of a boat to be present at the drivers' briefings.

Timing and location of the briefing will be communicated in the Race Instructions, handed out during race registration or communicated by a race bulletin. Roll call will be taken and all drivers shall sign in.

502.03.07.05 - Dry & Wet Pit regulations

The dry and wet pits are areas of danger and each team shall comply with the directions of the dry and wet pit officials and the technical scrutineers.

Once craned into the water, teams must remove their boats from the immediate area of the crane as soon as practically possible or as directed to the pontoons.

Boats are allowed out on the water only at the times indicated in the Race Instructions, with prior agreement from the OOD.

502.03.07.06 - Launch and recovery

All boats must be fitted with lifting eyes suitably engineered to withstand lifting the boat fully equipped and fuelled with an adequate safety margin. Therefore, each boat is also required to bring certified straps for launch and recovery.

A minimum of two team members must be present at launch or recovery.

All boats must be launch-ready on arrival at the crane (ropes, fenders on, covers off, etc.) Otherwise, the boat might be refused launch.

It is forbidden for any person to be on or in the race boat while the boat is being lifted.

502.03.07.07 - Official practice

At each event, there will be at least 2 free official practice sessions, unless force majeure or bad weather conditions do not permit it.

The official practice will be run on the same circuit as used for the race.

502.03.07.08 - Race procedures and race course

Race start and finish procedures will be detailed in the Race Instructions and during the drivers' briefings.

A short Endurance Group B race shall be a minimum distance of 38 nautical miles. A race lap cannot be less than 3 nautical miles.

During the start lap, the minimum distance from the start line to the first turn mark (buoy) shall be minimum 1 nautical mile. Races and courses are subject to modifications due to safety, bad weather or local authorities restrictions.

A complete lap is a lap as stipulated in the Race Instructions, taking into account all race buoys or their geographical positions as indicated in the Race Instructions in case of a destroyed buoy or disappeared or drifting buoy.

502.03.07.09 - VHF radio

Each boat must have on board an operational multi-channel marine VHF Radio.

502.03.07.10 - Racing vests

Racing Vests must always be worn during all water sessions. The choice and efficiency of the Racing vest is the sole responsibility of the wearer.

Inflatable Lifejackets are not permitted. Racing vests must have grab 'lapels' to aid in case of emergency.

502.03.07.11 - Helmets

Any person aboard any boat taking part in races must wear a helmet which complies with the standards in accordance with the list available on the UIM Website.

At least the upper 50 % (area) must be of a single bright or fluorescent red/yellow/orange/**Green** colour. No image recording device, however small, may be attached to helmets.

The wearer is entirely responsible for the efficiency, including the fitting, of his/her helmet. All organisers should repeat this rule in any relevant issued documents, written or verbal.

If a helmet is damaged in an incident, it cannot be used again and must be replaced.

502.03.07.12 - Head and Neck Restraint

All restrained competitors or members of crew in canopied /partially canopied boats must always wear a head & neck restraint system. It is the sole responsibility of the wearer to ensure that the Head and Neck restraint device that they are using is suitable for the application that they are engaged in. A Head and Neck Restraint device must be worn during Cockpit Evacuation / Immersion Training.

502.03.07.13 - Protective clothing

All crew members whilst racing must wear suitable protective clothing that covers the torso and all limbs to the wrists and ankles.

Protective clothing used must be durable enough to provide bodily protection and it is recommended to be **cut-proof**.

Restrained drivers and co-drivers must wear a racing suit ***which is fire retardant at all times when afloat. Similar rated fire-retardant gloves and racing boots must be worn.***

Fire retardant underwear is recommended. It is the sole responsibility of the wearer to ensure that the protective clothing that they are using is suitable for the application that they are engaged in.

502.03.07.14 - Race Marks or buoys

It is strictly forbidden for a race boat to retake a missed race mark or a missed race buoy. Recovering or attempting to recover a race mark or buoy from the course implies the immediate disqualification of that heat.

For each race mark (buoy) missed or not taken as prescribed in a race/heat, a one lap-penalty will be applied.

When a race mark has disappeared, drifted or has been destroyed, the drivers must follow the designated geographical position of the mark, as stipulated in the race instructions.

When a driver misses three times a race mark in the same race/heat, disqualification will apply.

In case a driver of a boat has damaged a race buoy, the driver must pay 300 Euro (or other amount when stipulated in the Race Instructions) to the local organizer or owner of the race buoys and a one lap-penalty will be applied.

502.03.07.15 - Flags

Green: start

Red: immediate stop of the race

Yellow: dangerous situation / attention to prepare for the race

Black with a visible boat number: disqualification – obligation to retire from the race.

Orange: to be shown by open boat which is retired. Strobe light must be on for retired cockpit boats.

White: indicates last lap

Chequered black and white: end of the race

502.03.07.16 - Finishing procedure // time limit

A boat shall be timed for completing a race when her bow crosses the finish line; When the leading boat completes the race and crosses the finish line, the chequered flag will be waved. The chequered flag will also be given to all subsequent boats that cross the finish line after the first boat.

Boats shall not begin a new lap if they cross the finish line after the leading boat has taken the chequered flag.

Boats will be ranked according to the number of laps completed and then the time it has taken to complete those laps.

There shall be a time limit so that the race shall end thirty minutes after the leading boat in its class has crossed the finish line and has been shown the chequered flag.

Given time penalisations will not be added to the actual race time re. the time limit. The actual time penalty will only be added to the race time in respect of the final classification.

502.03.07.17 - Post-race scrutineering

The top 3 classified boats will be weighed and checked after the race. They must immediately take their boats to the parc ferme, without stopping on the way and without touching, replacing or modifying anything.

The boats shall have a minimum post-race weight as per rulebook. The weights of the boats must be visible during weighing and the results published on the bulletin board in Race administration office and signed by the technical scrutineer. The time between the end of the last heat and the start of the awards ceremony must be at least 1 hour.

502.03.07.18 - Points eligibility

Unless a race is curtailed, to be eligible for race points, a boat must have completed the minimum number of laps announced at the briefing or issued in a race bulletin.

If not stated at this briefing, the minimum number of laps required to be completed shall be 70% of the total race distance, rounded up to the nearest lap.

Boats must take the chequered flag within the time limit to be eligible for race points.

In the event of a Stopped or Curtailed Race, if the 'winning boat' has completed:

- ***A minimum of 50 % of the actual programmed number of laps: full points will be awarded.***
- ***Between 25% but less than 50 % of the actual programmed number of laps: half points will be awarded.***
- ***Less than 25% of the actual programmed number of laps: No Points***

Restart: If conditions allow, A race can be restarted if less than 50% of the actual programmed number of laps has been completed.

In the event of a Stopped / Curtailed or Restarted race, boats must have completed a minimum of 70% of the laps completed by the 'winning boat' in their respective categories to be classified a finisher.

502.03.07.18.1 Stopping a Race

In case of force majeure or incident/accident, the OOD may stop the race by waving a red flag. This signal (red flag) will be given from the turn mark control boats and may be given by other Official Safety Boats. All boats slow down immediately and follow the race course at slow speed till the finish gate, and they may not overtake other race boats but remain in order when receiving red flag.

502.03.07.18.2 Curtailing a Race

A curtailed race is a race shortened by the OOD after the start. The signal to be used to announce it, is the waving of the chequered flag and the red flag simultaneously at the finish line. The O.O.D. can implement a curtailment decision at any time during the event, even in a multi-class race, provided the curtailment signal is broken out on the start/finish line. Once the curtailment signal has been broken out, all boats will stop racing at the end of their current lap. The first boat in each class, or subdivision, to be stopped by the curtailment signal becomes the “key” boat in that class. Any boat crossing the finishing line after the “key boat” will be classified considering its time and the number of laps completed.

502.03.07.19 - Race points and classification

Race points shall be awarded to the boat / driver combination. Points are not transferable to other classes or boats. Boat Hull cannot be changed during a single round of the Championship. Where there are several rounds of a championship, under exceptional circumstances a change of boat hull and transfer of points may be permitted by applying in writing to their National Authority for a dispensation. Any replacement boat must carry the same number e.g., of exceptional circumstances:

- Where a boat has being damaged beyond repair
- Where there is a delay in the replacement boat production and the driver is forced to compete in his/her older boat at start of season. For a UIM Titled event the PN Commission must be made aware of and authorize the change of hull by the NA.

No points will be given if a boat is disqualified for an infringement of the technical or sport rules. For the classification, points will be awarded as follows:

1.	400 pts	11.	22 pts
2.	300 pts	12.	17 pts
3.	225 pts	13	13 pts
4.	169 pts	14	9 pts
5.	127 pts	15	7 pts
6.	95 pts	16	5 pts
7.	71 pts	17	4 pts
8.	53 pts	18	3 pts
9.	40 pts	19	2 pts
10.	30 pts	20	1 pt

The overall classification for the Continental and World Championships shall be established by the addition of all points obtained by each driver in races counting towards the Championship.

When there are several rounds of a championship, the UIM Pleasure Navigation Commission at the start of the season may state that the points from a specific number of races count towards the Championship in that year. (e.g. Best 4 to of 6). In addition, the specified number of races cannot be less than 2/3 of the overall number of valid races in the same year (NB: ratified in UIM Pleasure Navigation Commission meeting of 14/12/2023, following survey of drivers on the Championship’s format).

The winner of the championship will be the boat who will have accumulated the highest number of points over all Rounds ***or the highest number of points on a defined number of races as decided by the UIM Pleasure Navigation.***

Championship points will only be valid when a Team has taken part in a least 50% of the overall championship races.

502.03.07.20 - Tie breaks

a) at an event/Round (counting up 2 races)

In case of a tie, i.e., equal points at the end of a Round or event, the winner shall be the highest positioned boat from the race run over the longest distance.

b) at the Continental or World championship

In case of equal points at the end of a championship, the winner shall be decided by the most first place finishes in all the races, then second place finishes, then third place finishes and so on.

If a tie still exists after this process has been exhausted, it shall be broken in favour of the higher placed boat of the final Round/event counting for the Championship.

502.03.07.21 - Podium ceremony

Attendance at the prize-giving / podium ceremony is mandatory for each driver/co-driver of the first three classified boats in each category.

Failure to do so without permission from the OOD/UIM Commissioner may lead to disqualification / withdrawal of Prizes.

Competitors must wear their race suits or smart casual team wear and decent footwear whilst on the Podium.

At the Final round of a UIM Championship, The UIM will provide gold, silver and bronze medals for the first three classified boats with the highest overall championship points in each category.

The local organizer will present prizes for the first three finishers in each class for the event (Round).

502.03.08 - CONTINENTAL AND WORLD CHAMPIONSHIP REQUIREMENTS FOR PLEASURE NAVIGATION ENDURANCE GROUP B

A person or a team can be proclaimed 'Continental Champion' in category Pleasure Navigation Endurance Group B only if at least three boats with competitors from two different nations have competed for the title.

A person or team can be proclaimed 'World Champion' in category Pleasure Navigation Group B only if at least three boats with competitors from three different nations have competed for the title.

A minimum of 10 entries in total for Group B (spread over the different subcategories) is recommended for organizing a World Championship or Continental Endurance Group B Championship.

The organizer must send the advance programme to the UIM Secretariat a minimum of two months before the date of the race. The members of the Pleasure Navigation Commission will verify that the requirements indicated in the regulations are met.

The UIM Pleasure Navigation Commission, when assigning to a certain nation the organization of the World or Continental Championship Endurance Group B indicates a period between two months and month prior to a scheduled World or Continental Championship event, as enrolment period for the teams willing to attend the event, for sending in their entry in the selected category to the organizing National Authority hosting the event. On entering an event, a guarantee of 300 Euro (maximum), or other amount as stipulated by the hosting National Authority (N.A.), has to be paid by the participating team on the account of the hosting N.A. In addition, each Team must submit copies of their valid International Licences and their letter of authorization to race abroad issued by their National Authority. (These documents are also necessary during registration with the race secretary)

The entry form, made up by the hosting N.A., must at least include the deadline date for enrollment (which is one month prior to the scheduled event), the bank details needed for payment of the guarantee to the hosting N.A., name of the driver(s) and their nationality, the e-mail address of the hosting N.A. for sending in the entry form, and the class the participating team is enrolling for.

A template of the entry form must be sent by the hosting N.A. to the UIM at least 2 months prior to the event so that UIM can publish the entry form on its website where the participating teams can download the document.

Once the enrolment term is expired (one month prior to the event), the National Authority organizing the World or Continental Championship will inform the UIM by sending them a list with the number of entries received in total, the names of the drivers and their nationality and also mentioning the categories in which those entries are enrolled. The UIM secretariat will inform all UIM Pleasure Navigation Commission members.

One month prior to the event date, the UIM according to UIM Pleasure Navigation Commission will confirm, by sending an e-mail with enrolment list to all National Authorities, the World or Continental Championship applied for by the National Authority on the foreseen date in all the foreseen categories or only in those categories where the minimum number of boats and nations is reached, based upon the minimum numbers required of inscribed competitors and Nations, as stipulated above.

In case the minimum number foreseen by this UIM Rule is not reached, the World Championship or Continental Championship will be completely cancelled or partially cancelled (only for the categories where the minimum number of participating boats and nations is not reached) and the financial guarantees will be paid back immediately.

The financial guarantees paid by the drivers in the categories where the minimum number of boats participants (3) and nations (2) is reached, will be paid back, either in cash during the Championship event weekend or by bank transfer at the latest days after the event.

In case of a Continental or World Championship with more than one event/Round counting for the Championships, the same requirements as above apply for the different rounds.

In case there are three correct inscriptions and one of the boats does not appear on the day of the race or does not pass the technical verification prior to the race, the championship or championship round will also be valid.

503 - POINT TO POINT COMPETITIONS

503.01

Point to Point competition is open to craft capable of undertaking independent, extended offshore passages in unprotected waters.

503.02 - CATEGORIES AND CLASSES

All Point-to-Point records are divided into three classes subject to Length Over All (LOA). LOA is measured using the method for Offshore Class 1.

Class	Class Parameters	V-Hull	Catamaran
A Unlimited	UIM Race Class or APBA Race Class & Canopy Required	over 16' 5" up to 30ft	over 16' 5" up to 30ft
		30' up to 35'	30' up to 35'
		35' up to 40'	35' up to 40'
		40' up to 45'	40' up to 45'
		45' up to 164'	45' up to 164'
B Limited*	< 100 mph	over 16' 5" up to 30ft	over 16' 5" up to 30ft
		30' up to 35'	30' up to 35'
		35' up to 40'	35' up to 40'
		40' up to 45'	40' up to 45'
		45' up to 164'	45' up to 164'
CC Center Console*	Production Boat & < 90 mph	over 16' 5" up to 30ft	over 16' 5" up to 30ft
		30' up to 35'	30' up to 35'
		35' up to 40'	35' up to 40'
		40' up to 45'	40' up to 45'
		45' up to 164'	45' up to 164'

503.03 – BOAT REQUIREMENTS

503.03.02 - PROPULSION

Any method of mechanical force.

503.03.02 – STEERING

Any type of automatic steering is allowed.

503.03.03 – NAVIGATION

Any type of navigation equipment is allowed and there is no objection to any type of information or advice being transmitted to or from the vessel. However, the vessel must be driven and navigated by the onboard crew.

503.03.04 – LIFTING POINTS

Where physically possible, teams should ensure that their boat has fixed lifting points, and their own certified lifting strop, which should be carried in the boat. For all boats, the lifting positions of the boat for emergency lift by crane slings must be clearly marked on either side of the boat.

503.03.05 - BUOYANCY

It is recommended that boats should have enough buoyancy in the boat or in the material used for its construction to ensure that the boat floats if capsized or holed.

503.03.06 – BILGE PUMPS

Suitable & automatic bilge pumps shall be fitted to the boat capable of pumping out all sections of the boat even where water-tight bulkheads are fitted. They shall be accessible and be fitted with a suction pipe leading to the lowest point of the bilge and with a discharge pipe overboard. There shall also be at least one manual bilge pump in the boat.

503.03.07 – DECK FITTINGS

All boats must have guard rails or handholds as rails or handles raised above the deck of a suitable material or wire in stanchions. A single rail would suffice. A rope secured to the bow and made fast in the cockpit will not be accepted.

Non-skid is required.

503.03.08 - TOWING

All vessels must be fitted with a properly designed towing point of adequate construction and strength for the boat to be towed when waterlogged for extended periods. A tow line suitable in length and strength for the boat in all weathers must be carried by all boat and can be permanently attached to the strong point during the competition unless the crew can demonstrate that a towing line can be easily attached to the towing point whilst at sea. This towing line should have a fixed loop to provide ease of attachment.

In addition, each boat should carry sufficient fenders & warps as to be able to dock or raft independently in port or to be able to raft suitably to another vessel if assistance was either required or being offered.

503.03.09 - ANCHOR

In addition to the normal anchor, a Sea anchor with adequate anchor lines must be carried at all times and shall be of a weight and type adequate to hold the boat and shall be properly stowed in an accessible place.

503.03.10 - COMPASS

For all classes it is permitted to use electronic steering compasses and/or electronic position fixing equipment. It is expressly forbidden to interface any of this equipment to the steering system. The Race Committee has the right to decide whether there was outside assistance or not.

503.03.11 – NAVIGATION LIGHTS/STROBE LIGHT

Navigation lights in working order shall be carried in accordance with International Rules for the Prevention of Collisions at Sea.

All boats shall have a White or Orange High Intensity Strobe Light fitted to indicate “coming off the plane” but not needing assistance. The strobe light must be able to be operated by the throttle man and should be operated by the throttle man if a problem occurs, to enable any following race boats to take avoiding action. The strobe light shall be mounted on the top rear of the canopy. When dual canopies are used, the light may be on or behind either one. This strobe light may also be used as a substitute for the orange retirement flag when returning to port under reduced power.

503.03.12 – FOG HORN/TORCH (FLASHLIGHT)

All boats shall carry an efficient fog horn and a powerful torch (flashlight).

503.03.13 – FUEL TANKS

Fuel transfer at sea is only permitted between your own fixed onboard tanks. Race fuel may not be stored or carried on board in any jerry-can type of container.

503.03.14 - BATTERIES

Batteries shall be housed in ventilated compartments, mounted upon a secure and solid platform and be fitted with an isolator switch. The battery isolator switch position must be clearly marked for safety reasons.

503.03.15 – FIRE PREVENTION

All boats with inboard engines shall carry a fixed automatic fire extinguishing system. This system shall be properly installed, engineered and maintained. Sensors and injectors shall be in danger regions of the engine compartment/s. ALL boats, including inboards, shall carry a minimum of 2 fully charged dry powder 2kg fire extinguishers.

503.04 – BOAT SAFETY EQUIPMENT

It must be understood that in Point-to-Point racing, every team/crew must be prepared for any and all eventualities with regard to their own safety. If any team experiences difficulties or an emergency during the race, then they must be aware and prepared to be effectively on their own until rescue teams (from whatever source) can arrive. Every team must therefore have emergency plans which must include a risk assessment setting out how they would deal with an on board emergency situation until such time as rescue teams arrive.

503.04.01- INFLATABLE LIFE RAFT

It is mandatory that every boat carries one certified and in date Inflatable Life Raft capable of carrying the complete crew, together with adequate fresh water and a first-aid kit. The life raft shall be stowed in an easily accessible position so that in the event of emergency the life raft can be quickly released, particularly in the event of fire.

503.04.02 - FLARES

All boats must carry minimum of 2 approved flares/ smoke for emergency signaling. If any flares are deployed, they must be replaced before the start of the next leg.

503.04.03 - RADIO REQUIREMENTS

All competing boats must carry a fixed VHF transceiver with an aerial output of not less than 25 watts pass SWR (standing wave ratio) and power check.

A multi-channel waterproof hand held VHF radio, which should be carried by one crew member at all times.

503.04.04 - TRACKERS

All competing boats may be required to carry trackers supplied by Event Management which will assist safety control with an online map showing the position of every competitor.

503.04.05 - FIRST AID KIT

All boats shall carry an adequate medical kit to include 1 x foil blanket + thermal protective aids for each crew member.

503.04.06 - RADAR REFLECTOR

It is recommended that all boats carry a RADAR reflector suitable for the boat or a Search & Rescue Transponder – SART.

503.04.07 - SAFETY EQUIPMENT

All Boats must start and finish and carry throughout the race the following minimum equipment:

- Whistle
- Knife
- Medical Compress
- VHF Handheld radio
- Carbon monoxide sensors and alarms
- Manual Bilge Pump
- Foot Pump (RIBS only)
- Tow Rope
- Sea anchor and rope/chain minimum length 50 meters

- Fog Horn and Torch (flashlight)
- Two 2kg dry powder fire extinguishers suitably mounted close to engines or crew.
- Orange retirements flag 0.60m x 0.40m
- Inflatable Life raft compliant with rules
- Flares
- VHF Handheld radio with channel 32 (M)
- Tracker System as specified or provided by event organizer
- Adequate first aid kit. 1 x foil blanket + thermal protective aids for each crew member.
- Radar Reflector or suitable alternative.
- Emergency Grab Bag: An Emergency Grab Bag must be carried on board at all times to include, fresh water, day and night flares, Thermal protective Aids, First Aid Kit. Recommended to include portable VHF Radio, Passports, money and credit cards (Cuba, Bahamas, Puerto Rico)
- Guardrails, handholds
- Compass
- Engine cut-off attachments for all crew
- Battery isolator switches easily accessible to crew
- GPS, RADAR equipment as per Racing Instructions.

504 - PARALLEL SLALOM COMPETITIONS

504.01

The Parallel Slalom competition is open only to pleasure craft duly homologated.

Craft competing shall be equipped with strictly standard engines and propellers. Craft shall be equipped with safety cut-off device. For slalom competitions the following pleasure navigation categories may participate, each of them divided into classes according to their engine capacities :

504.02 - CATEGORIES AND CLASSES

- Inflatable with outboard;
- Inflatable with out/inboard;
- Boats with outboard;
- Boats with out/inboard and inboard;

Each of these categories is divided in classes as follows:

Inflatable with outboard

4 Stroke	2 stroke	Class
Up to 550cc	Up to 550cc	A
551cc – 1,000cc	551cc -750 cc	B
	751cc – 1,100cc	C
	1,101cc – 1,500cc	D
	1,501cc-2,000cc	E
	2,001cc-2,600cc	F
	2,601cc-3,000cc	G
	3,001cc-4,000cc	H

Inflatable with I.O.B.

4 Stroke	2 stroke	Class
	up to 1,350cc	A
	1,351cc - 5,700cc	B
	5,701cc - 7,450cc	C
	7,451cc - 8,200cc	D
	8,201cc - 10,000cc	E

Boats with outboard

4 Stroke	2 stroke	Class
up to 550cc	up to 550cc	A
551cc - 1,000cc	551cc - 750cc	B
	751cc - 1,100cc	C
	1,101cc - 1,500cc	D
	1,501cc - 2,000cc	E
	2,001cc - 2,600cc	F
	2,601cc - 3,000cc	G
	3,001cc - 4,000cc	H

Boats with I.O.B. or I.B.

4 Stroke	2 stroke	Class
	up to 1,350cc	A
	1,351cc - 5,700cc	B
	5,701cc - 7,450cc	C
	7,451cc - 8,200cc	D

505 - HISTORICAL BOATS

505.01- EVALUATION FORM FOR UIM-ASDEC CERTIFICATION

Points for the evaluation of Historical boats for award of the UIM/ASDEC Certificate or for inclusion in the Historical Naval Register shall be awarded on the following basis:

BOAT'S NATIONAL AUTHORITY			YEAR OF CONSTRUCTION KEEL NUMBER	
BOATBUILDER	MODEL	ENGINE MANUFACTURER	MODEL	
SHIPOWNER			ENTRY NUMBER	

Maximum score 70 points. (the maximum score of the three Scrutineers is 210 points).

The boats that do not get the minimum score in every category, obtained by adding the points assigned by the three Scrutineers (minimum of: 12 points for Age, 6 points for History, 3 points for Importance, 18 points for Originality, 18 points for Maintenance, 3 points for Aesthetics) are considered Historical Aspirant.

505.02 - AGE

The score will be given in proportion to the documented age of the boat

Guide Index from 1 to 10 points, with a maximum increase to 20 points.

Up to 25 years old (classic boats)	points 1
■ Boats less than 25 years old but on designs of more than 25 years old (Total rebuild or copy)	points 2
■ Boats less than 25 years old, belonging to a series with more than 25 years of production	
■ Boats more than 25 years old, built after 1st January 1970	points 4
■ Built between 1960 and 1969	points 5
■ Built between 1950 and 1959	points 6
■ Built between 1940 and 1949	points 7
■ Built between 1930 and 1939	points 8
■ Built between 1920 and 1929	points 9
■ Built before 1920	points 10

Total scored points by :

- Scrutineer 1 :
- Scrutineer 2 :
- Scrutineer 3 :

If reliable age: scored points x 1.5

If documented age : scored points x 2.0

Total Points :

When the established age of the build is more than 25 years, the score is doubled. Nevertheless, if there are substantial external modifications (proportional to the size of the boat) effected in the last 25 years, the score may be increased by 50% with a rounding off to the greater whole point. In the absence of official documents or photos in dated publications, the age may be estimated from objective elements (engine, design of the boat, structural particulars etc...) without going back to the precise year, and the score based on the estimated age. may be increased by a maximum of 50%.

505.03 - HISTORY

Judged on the production of the documents showing the boat's history and the nautical competitions in which it has competed. The authenticity and the rarity of the documents produced shall also be taken into consideration.

Guide Index Maximum 10 points

Official documents (Lloyd's Registry, navigation's license Measurement certificate etc...);	points 1
Books in which are reproduced the boat and its history; (copy of the pages)	points 1
Books concerning the boatbuilder's history (copy of the summary);	points 1
Press articles concerning the boat, the mode or the Boatbuilder;	points 1
Unpublished news, written and documented on the history of the boat or of the yard;	points 1
Photographic or filmed documentation of the launch or the building in the yard;	points 1
Photographic documentation of the boat engaged with activity and meetings;	points 1
Photographic documentation of restoration or maintenance;	points 1
Structural plans, specific of building, and unpublished documents;	points 1
Operating and maintenance booklets and documents of the Period and contemporary journalism writing on current affairs;	points 1

Total scored points by

- Scrutineer 1 :
- Scrutineer 2 :
- Scrutineer 3 :

Total Points :

505.04 - IMPORTANCE

Judged on the uniqueness, rarity and peculiarity of the history, of technology, of success, etc. of the boat. GUIDE

INDEX Maximum Points 10

Same family or owner	points 1
Options: Of international famous owners	points 2
Of well-known owners at National level	points 1
For having participated to competitions, meetings raids, war events	points 1
Famous designer	points 1
Famous Boat builder	points 1
Monotype or rare example of craftmade Boat builder unknown or not much known, or exclusive model of famous Boat builder the first or last current model of famous Boat builder, or rare example of imitated series of a famous Boat builder	points 1
Important for technique or aesthetics and constructional innovations	points 1
Important for success of sale	points 1
Important for success of collection	points 1

Total scored points by

- Scrutineer 1 :
- Scrutineer 2 :
- Scrutineer 3 :

Total points :

505.05 - ORIGINALITY

Judged on the authenticity of the boat and its constituent elements.

Guide Index Maximum points 10.

Open small boats with mixed propulsion, inboard and oars or engine sail

- Options: Original plan not modified; points 2
Original plan modified or updated more than 25 years ago by the same designer or yard; points 1
- Options:
Boat's materials and designed superstructures never replaced (excluding the replacement of the bottom planking, for safety reasons); points 2
Boat's materials and of designed superstructures with invisible partial replacement; points 1
- Options: Original engine; points 3
Engine of similar type; points 1
- System of restoration and painting; Original windscreen, porthole and glasses centring, awnings, benches and dunnages;. points 1
- Original mast and rudder, tank and battery close to the original. Sails, halyards, shrouds, sheets, rigging, blocks, oars & rowlocks; points 1
- Tiller, winch, dashboard. Boats internal visible upholstery; points 1
- Deck equipment, navigation and metallic fittings; points 1

Total scored points by

- Scrutineer 1 :
- Scrutineer 2 :
- Scrutineer 3 :

Total points :

Runabouts and day cruisers (with deck) inboard and outboard.

- Options: Original plan not modified; points 2
Original plan modified or updated more than 25 years ago by the same designer or yard; points 1
- Options:
Boat's materials and designed superstructures never replaced (excluding the replacement of the bottom planking, for safety reasons); points 2
Boat's materials and of designed superstructures with invisible partial replacement; points 1
- Options: Original engine and transmission. points 2
Rudder, tank, battery, tubes and original plants close to the original; points 2
Engine of similar type; points 1
- System of restoration and painting. (materials and colour); points 1
- Original windscreen, porthole, skylights, dashboard, instruments, wheel, hand drives, and deck equipment and glasses centring, awnings, benches and dunnages; points 1
- Awnings, hoods, original seat or similar to original; points 2
- Options: Aped as the boatbuilder updatings; points 1

Total scored points by

- Scrutineer 1 :
- Scrutineer 2 :
- Scrutineer 3 :

Total Points:

Cabin cruiser and motor yacht

- Options: Original plan not modified; points 2
- Original plan modified or updated more than 25 years ago by the same designer or yard; points 1
- Boat's materials and designed superstructures never replaced or imperceptible partial replacement; points 1
- System of restoration and painting. (materials and colour); points 1
- Original windscreen, porthole, skylights, dashboard, instruments, wheel, hand drives; points 1
- Original mast and deck equipment or like the original; points 1
- Furnishing and tapestry suit to the period; points 1
- Original internal division into compartments (possible limited Modifications functional to internal division inside are tolerated); points 1
- Wind glasses, wind sleeves, gangways, and accessories of the period;points
- Total scored points by
- Scrutineer 1 :
- Scrutineer 2 :
- Scrutineer 3 :

Total Points:

Workboats and military craft

Guide Index Maximum 10 points:

- Options:
- Without modifications to the original plan and with no external structural or behavioural modifications; points 2
- Limited internal modifications; points 1
- Boat, deck and deckhouse with matching or original materials; points 1
- System of restoration, painting and matching colours; points 1
- Mast, tackles, heating appliances and original instruments; points 1
- Options:
- Engine and original mechanical system; points 2
- Close to the original; points 1
- Original Machine room, bridge and bathrooms; points 1
- Furnishing and upholstery of cabins and wardroom in the style of the period; points 1

Total scored points by

- Scrutineer 1 :
- Scrutineer 2 :
- Scrutineer 3 :

Total Points:

Racing Boats

- Boat without aesthetic modifications; points 1
 - Boat with original materials (excluding minimal restoration); points 1
 - Original deck, windscreen, fairing and cockpit; points 1
 - Original System of restoration, painting and matching colours; points 1
 - Options:
 - Original engine; points 3
 - Similar engine; points 1
 - Tank, wheel, rudder, dashboard, hand drives and instruments original and matching; points 1
 - Battery, tubes, deck's equipping and carpentry close to the original; points 1
 - Original seats and ceiling; points 1
- Total scored points by
- Scrutineer 1 :
 - Scrutineer 2 :
 - Scrutineer 3 :

Total Points:

505.06 - MAINTENANCE

Judged on efficiency, general condition of hull and deck materials and paintings, of upholstery and furniture, operation and appearance of engines and fittings independently of their originality.

Guide Index Maximum Points 10

- Options Materials of construction as original or painted without serious flaws or disfiguring spots (small imperfections reflecting the age of the material are allowed); points 3
- Options as above but with partial restoration; points 2
as above but with partial replacements; points 1
- Painting or antifouling of the hull, painting of the upperworks in very good condition; points 1
- Options: Paintings (or polishing) of hull and superstructures in very good condition; points 2
in good or fairly good condition; points 1
- Paintings and cleaning of bilges in very good conditions, paintings and upholstery of the interior well preserved; points 1
- Chroming or cleaning of deck fittings; points 1
- Maintenance of engines, fittings and engine room; points 1
- Patina of general use, internal and external, enchanting (charm due to the level of maintenance and not to recent restoration); points 1

Total scored points by

- Scrutineer 1 :
- Scrutineer 2 :
- Scrutineer 3 :

Total Points:

505.07 - BEAUTY

Judge on beauty and charm, proportions, elegance in shape, materials and colours; (changes provided over time do not affect beauty if well designed and built).

Guide Index Maximum 10 Points

- Options: Harmonious external lines, refined and charming; points 4
- Harmonious and pleasant external lines; points 3
- Essential and balanced external lines; points 2
- External lines without homogeneous design, but acceptable ; points 1
- Exterior colours and look of elegant materials; points 1
- Options: Inside with organic and refined design of furniture in the style of the boat; points 2
Spartan but sailor-like inside; points 1
- Inside: colours and finishing materials with charming look; points 1
- set of period accessories, if contributing to the charm ; points 1
- design level, realisation and finishing of the inside and outside; points 1

Total scored points by

- Scrutineer 1 :
- Scrutineer 2 :
- Scrutineer 3 :

Total Points:

TOTAL SCORE OF THE THREE SCRUTINEERS/...../.....

Date _____ Place _____

Scrutineers Name and signature

- 1. - _____
- 2. - _____
- 3. - _____

506 - RULES FOR UIM MARATHON RACING

506.1 - GENERAL

506.1.1 - RULES

The general UIM Pleasure Navigation racing rules are to be applied. In cases of conflicts between the general rules and the class rules (and specifications), the class rules have precedence

506.1.2 - MINIMUM AGE

The minimum age for competitors in all of the marathon classes is 18 years.

506.1.3 - CLARIFICATION

In these Rules, the words “shall” or “must” means mandatory; the word “should” means recommended.

506.1.4 - LICENCE

The issuing of International licences is the task of the National Authority of the competitor. The National Authority of the licence holder must verify that the competitors have the necessary experience and skill to take part in Endurance Marathon events.

As a reference for minimum competence, competitors who have not previously held a Marathon Licence must submit a detailed CV of their racing and boating experience to their National Authority. This CV must demonstrate practical experience and theoretical knowledge to a minimum standard recognised nationally or a military equivalent and approved by the applicants National Authority (for example UK RYA qualifications of Day Skipper, Coastal Skipper, Yachtmaster or Advanced Powerboat would be acceptable standards).

Both driver and co-drivers must have first aid and resuscitation knowledge as defined by Red Cross or similar.

506.1.5 - SEA SURVIVAL CERTIFICATE

A current sea survival certificate, equivalent to an IMO standards of training, certification and watchkeeping for seafarers (STCW) Basic Sea Survival Course, must be held by all crew members.

506.2 - COMPETITION RULES

506.2.1 - OUTSIDE ASSISTANCE

Competitors may refuel during a race at recognised port or marina fuel outlets within harbour confines. Ship to ship or air to ship refueling at sea is not permitted.

Competitors may utilise outside assistance to effect repairs to machinery, structure, navigation or safety equipment once berthed in a recognised port or marina.

No other outside assistance is allowed during a race.

Any competing craft may be towed and if a tow is accepted, then that competitor will be treated as a retirement from the race or that particular leg of the race.

506.2.2 - IDENTIFICATION

All competing craft must carry race numbers as laid down in the UIM Rules; this includes deck numbers. Race numbers shall include a prefix letter “A”, “C”, “S” and “E” to match each sub-class of Marathon classification.

506.3 - RACE BOATS

506.3.1 - HULL LENGTH

The minimum and maximum hull length for all competing craft is as defined as per Class Classifications.

UIM standard measurement procedure is used in all cases.

506.3.2 - SPEED

All competing craft must be capable of exceeding 40 knots.

506.3.3 - MONOHULL BOATS

In the Spirit of Endurance Marathon Racing, all competing craft must be Monohull or stabilised Mono Hull unless otherwise agreed by the race organizer.

All open boats must have their bow painted fluorescent Yellow at least 0.5m. The number of riding crew members must be written in black in at least 0.25 m high in the Yellow area.

All closed cockpit boats must have their bow painted fluorescent Orange at least 0.5m. The number of riding crew members must be written in black in at least 0.25 m high in the Orange area.

506.3.3.1 - OPEN BOATS

Boat builders/designers must supply confirmation from a recognized body that the boat is designed for such activities and to race in a given class.

506.3.4 - REINFORCED COCKPIT BOATS

All competitors and crew members who race in boats with restraints, canopies, and partial reinforced cockpits must hold a current immersion test certificate.

Reinforced cockpit boats must have a current Measurement Certificate and it is recommended that they comply with full UIM 508 rules for reinforced cockpit boats.

Crew must be able to demonstrate that they can safely exit the boat (maximum recommended exit time 30 seconds) This may be subject to scrutineer testing at events.

The nominated skipper of the vessel accepts ultimate responsibility for complying with all of the above requirements.

Carbon monoxide sensors and alarms must be fitted in all reinforced cockpits boats.

506.3.5 - PARTIAL CANOPY BOATS

All competitors and crew members who race in boats with restraints, canopies, and partial canopies must hold a current immersion test certificate.

Partial canopies may be permitted subject to the technical inspector's approval, this process must be commenced a minimum of 3 months before the event.

There must be an opening hatch with a minimum open space sufficiently large (minimum 55cm X 82.5cm) for each person in the boat to exit immediately. Alternatively, there must be an open space in the rear of the craft sufficiently large (minimum 1.3m X 1.3m) for all crew to exit the boat immediately. Access at this opening must not be restricted in any way whatsoever.

Partially canopied boats may have restraint systems fitted which, if fitted, must comply with the following Offshore Rules: 508.01 (Crew Immersion Test) , 508.16 (Air Supply), 508.18 (stop buttons for engine cut- off), 508.20 (Rear of Head Protection) and 508.21 (Specification of Harness).

Additionally, the following rules apply :

1. Boat builders/designers must confirm in writing that the boat is designed for such activities and to race in a given class. This confirmation to include key safety points below, with detailed technical drawings supplied as appropriate.
2. Crew must be able to demonstrate that they can safely exit the boat (maximum recommended exit time 30 seconds) This may be subject to scrutineer testing at events.
3. Seat belt mounts must be of appropriate strength and position, considering the boats maximum designed speed – see 508 rules.
4. Structure of the partial canopy must be of similar strength to the hull/running surface of the boat.
5. The screen must be of a suitable materials and have flanges adequate to offer the strength required to meet the anticipated loads and speed of the craft.
6. All crew must have in date immersion test training and hold a current immersion test certificate.
7. Doors or hatches must be so designed to allow them to be easily opened from inside and out and must be labelled to allow rescuer to immediately understand opening system and backup system – hinges must have removable pins.
8. There must be an air system provided for each crew member – spare air systems are not acceptable.
9. There must be a minimum clearance between seats or door aperture of 40cm if this is the primary exit route.
10. The nominated skipper of the vessel accepts ultimate responsibility for complying with all of the above requirements.
11. Carbon monoxide sensors and alarms must be fitted in all canopied boats.

506.3.6 - SEAT BELTS / RESTRAINTS

No seat belts or restraints whatsoever are permitted in open boats, i.e. boats with no canopies or boats with no partial canopies.

All competitors and crew members who race in boats with restraints, canopies, and partial canopies must hold a current immersion test certificate.

506.3.7 - REINFORCED WATER DEFLECTOR

ALL Craft with a top speed in excess of 50 knots which do not have a forward cabin structure must have a Reinforced Water Deflector over and under the deck, designed and constructed of materials with sufficient strength to provide adequate crew protection. The forward fairing on deck must rise to a minimum height of the chin of the tallest crew member when in the normal driving position. The top 5cm of the water deflector must be at least 45 degrees from the horizontal with a minimum of 30cm width per person measured transversely in the horizontal plane. The Reinforced Water Deflector must be designed and constructed so as to present no hazard if the crew is thrown forward and must be so designed that it would not restrict the crew from being ejected in all cases. Open RIBs must have a solid fitted console to deflect water. In addition, all vessels must have a means of preventing the riding crew from sliding forward under the foredeck when in their normal racing position. A bulkhead or suitable kick-board in front of each of the riding crew must be fitted and be of sufficient strength to prevent the riding crew from forward movement in the event of rapid deceleration. The bulkhead/kick-board must be secured so that there is no more than 1 inch space between the crews' floor and the bulkhead.

506.3.8

All competing craft must be capable of going astern.

506.3.9 - LIFTING POINTS

Race instructions may require that competitors carry their certified lifting strops in their boat throughout the race. For all boats, the lifting positions of the craft for emergency lift by crane slings must be clearly marked on either side of the boat.

506.3.10 - BUOYANCY

It is recommended that enough buoyancy is provided in the race boat or in the material used for its construction to ensure that the boat floats if capsized or holed.

506.3.11 - BILGE PUMPS

Suitable & automatic bilge pumps shall be fitted to the boat capable of pumping out all sections of the boat. Pumps are recommended even where water-tight bulkheads are fitted. They shall be accessible and be fitted with a suction pipe leading to the lowest point of the bilge and with a discharge pipe overboard. There shall also be at least one manual bilge pump in the boat.

506.3.12 - PUMP

All RIBS shall carry both Manual Bilge and Air Inflation pumps which can be either a hand or foot pump, both capable of being operated below the gunwale.

506.3.13 - DECK FITTINGS

All boats must have guard rails or handholds as rails or handles raised above the deck of a suitable material or wire in stanchions. A single rail would suffice. A rope secured to the bow and made fast in the cockpit will not be accepted.

506.3.14 - TOWING

All vessels must be fitted with a properly designed towing point of adequate construction and strength for the boat to be towed when waterlogged for extended periods. Tow lines suitable in length and strength for the boat in all weathers must be carried by all craft and must be permanently attached to the strong point during races unless the crew can demonstrate that a towing line can be easily attached to the towing point whilst at sea. This towing line must have a fixed loop to provide ease of attachment.

In addition each boat should carry sufficient fenders & warps as to be able to dock or raft independently in port or to be able to raft suitably to another vessel if assistance was either required or being offered.

506.3.15 - ANCHOR

In addition to the normal Anchor, all boats must carry a sea anchor (drogue) suitable the size and weight of the vessel.

506.3.16 - COMPASS

Compass, Charts/back-up navigation and Nautical Almanac:

1. Compass - All boats must be equipped with a liquid filled magnetic compass. (Handheld or Fixed) If fixed compass deviation cards for magnetic compasses must relate to adjustment within the 12 months prior to the date of the event. Electronic compasses may be used in addition.
2. Charts/back-up navigation system – All boats must carry at all times EITHER

A comprehensive set of paper charts which must be in date and corrected to current Notices to Mariners. These charts must be of suitable scales and detail to enable safe navigation over the entire course.

OR

A properly installed electronic chart plotter containing chart data of suitable scales and detail to enable safe navigation over the entire course. In addition to the installed chart plotter a portable chart plotter containing chart data of suitable scales and detail must be carried to enable safe navigation over the entire course. This additional unit must be provided with additional emergency batteries to ensure a minimum of 8 hours operation.

3. Nautical Almanac – All boats must carry at all times a nautical almanac providing detailed navigational information of the entire course.

506.3.17 - NAVIGATION LIGHTS

Navigation lights in working order shall be carried in accordance with International Rules for the Prevention of Collisions at Sea.

506.3.18 - FOG HORN / TORCH

All boats shall carry an efficient fog horn and a powerful torch.

506.3.19 - FUEL TANKS

Fuel transfer at sea is only permitted between your own fixed onboard tanks. Race fuel may not be stored or carried on board in any jerry-can type of container.

506.3.20 - BATTERIES

Batteries shall be housed in ventilated compartments, mounted upon a secure and solid platform and be fitted with an isolator switch. The battery isolator switch position must be clearly marked for safety reasons.

506.4 - ENGINES

506.4.1 - ENGINE LIMITS

Engine limits are as described in the Class classifications.

506.4.2 - ENGINE DESCRIPTIONS

ENGINE DESCRIPTIONS for all classes except:

- a) Grand Sport (S) & Grand Touring (E) Classes, all engines must be "Low Emission Engines"
- b) Engines must be based on currently, or previously advertised/available mainstream production units available to the general public through normal distribution channels with a minimum production run of 500 units.
- c) Super Marathon class – engines are free.
- d) Within Grand Touring (E) Class – Height adjustable hydraulic engine jacks are NOT permitted.

506.4.3

Single engined craft and single shaft driven boats may compete. All such boats MUST carry an auxiliary engine for use in emergency breakdowns capable of propelling the craft at 5mph for a minimum of 35 miles. This engine can be stowed in the boat but must be shown to be sufficiently retained so that it will not work loose or cause damage.

506.4.4

Boats with more than one outboard engine or outdrive must have a properly engineered tie-bar system.

506.4.5 - ENGINE MOUNTINGS

Outboards: Engine mountings shall be attached to the transom with at least 4 bolts, which shall be either pinned or lock-nutted.

Inboards: Engine mountings shall be sound and the mounting bolts securing to the hull shall be pinned or lock-nutted. Engines shall be enclosed in their own compartment/s with the exception of normal ventilation. Each and every engine need not be contained in its own compartment. The compartments shall have rigid covers.

506.5 - SAFETY EQUIPMENT FOR THE BOAT

506.5.1 - EMERGENCIES

It must be understood that in Marathon (Endurance) Racing every team/crew must be prepared for any/all eventualities with regard to their own safety. If any team experiences difficulties or an emergency during the race, then they must be aware and prepared to be effectively on their own until rescue teams (from whatever source) can arrive. Every team must therefore have emergency plans which must include a risk assessment setting out how they would deal with an on board emergency situation until such time as rescue teams arrive.

506.5.2 - INFLATABLE LIFE RAFT

It is mandatory that every boat carries one certified and in date Inflatable Life Raft capable of carrying the complete crew, together with adequate fresh water and a first-aid kit. The life raft shall be stowed in an easily accessible position so that in the event of emergency the life raft can be quickly released, particularly in the event of fire.

The life raft is recommended to comply with ISAF Offshore Special Regulations (OSR) Appendix A Part 2 or ISO 9650 Type 1 Part 1, Group A standard, and should be fitted with a boarding ramp. (Or equivalent NA approved standards)

506.5.3 - FLARES

All boats will carry an Offshore. standard flare pack comprising: 4 red parachute rockets, 4 red hand held, 2 orange smoke hand held, and 4 white collision hand held flares in a waterproof canister. If any flares are deployed must be replaced before the start of the next race.

506.5.4 - VHF RADIO

All boats will carry a shipboard installation of a fully synthesized VHF transceiver with GMDSS capability carrying all 55 International Channels, with an aerial output of not less than 25 watts. Organisers may require additional channel(s) to be programmed into this radio to comply with local regulations. In addition, a multi-channel waterproof hand held VHF radio, which should be carried by one crew member at all times when racing. Each vessel must have a Ship's Licence for their radio equipment and at least one crew must have an Operator's Licence, both Licences to be checked at Race Control and be available for scrutineering.

506.5.5 - E.P.I.R.B.

A portable emergency position indicating radio beacon (E.P.I.R.B.) operating on 406 MHz shall be carried and stowed in an easily accessible position.

506.5.6 - TRACKER SYSTEM

Some long distance Marathon Races may require tracker systems, this decision will be made by the organisers prior to the event and details provided in the Advance Race Instructions,

506.5.7 - FIRST AID KIT

All boats shall carry an adequate medical kit and emergency thermal protective aids for each member of the crew.

506.5.8 - RADAR REFLECTOR

All boats must carry a RADAR reflector suitable for the boat or a Search & Rescue Transponder - SART.

506.6 - SAFETY EQUIPMENT FOR EACH CREW

506.6.1 - MEDICAL COMPRESS & KNIFE

All crew must carry on their person whilst racing a whistle, medical compress and a knife.

506.6.2 - SAFETY EQUIPMENT

All Boats must start and finish and carry throughout the race the following minimum equipment:

UIM RULE ITEM OF EQUIPMENT

- Carbon monoxide sensors and alarms for boat with full or partial canopies
- Certified Lifting strops (for boat fitted with lifting points)
- Manual Bilge Pump
- Foot Pump RIBS only
- Tow Rope and Warps
- Anchor and rope/chain minimum length 50 metres
- Additionally all boats must carry a sea anchor of suitable size for their particular vessel.
- Fog Horn and Torch
- Two 2kg dry powder fire extinguishers suitably mounted close to engines or crew.
- Orange retirements flag 0.60m x 0.40m
- Auxiliary engine (single engine race craft only)
- Inflatable Liferaft compliant with rules
- Flares: - 4 x Red Rocket, 4 x Red Handheld
- 2 x Orange Smoke, 4 x White Collision
- 1 x Mini Flare pack to be carried over person
- VHF Handheld radio with channel 32 (M)
- 1x E.P.I.R.B operation on 406 MHz. Recommendation that 1 per person is carried.
- Tracker System as specified or provided by event organiser
- Adequate first aid kit. 1 x foil blanket + thermal protective aids for each crew member.
- Radar Reflector or suitable alternative.
- Emergency Grab Bag: An Emergency Grab Bag must be carried on board at all times to include, fresh water, day and night flares, Thermal protective Aids, First Aid Kit. Recommended to include portable VHF Radio, Passports, Money and credit cards.
- Guardrails, handholds
- Liquid Magnate Compass
- Engine cut-off attachments for all crew
- Battery isolator switches easily accessible to crew
- A Fixed VHF transceiver with GMDSS capability.
- GPS, RADAR equipment as per Racing Instructions.
- Satellite Telephone. For all Ultra Marathon Races where an area of the courses is out of range of VHF communications, an operational satellite telephone must be carried on board at all times.

506.7 - TURN MARKS AND MISSED MARKS

Turn Marks

All marks, including GPS marks will be laid in the approximate positions referred to in the race instructions. It is the competitor's responsibility to follow the geographical course as described in race instructions and to drive close enough to the course marks to ensure that they have been seen to pass them correctly.

Competitors who do not follow the geographical course as described in race instructions will be disqualified from the race or in the event of multi-leg events they will be disqualified from that leg of the race.

The Event Race Instructions will specify the colour and shape of the course marks.

When a race mark has disappeared, drifted or has been destroyed, the drivers must follow the designated geographical position of a mark, as stipulated in the Race Instructions.

If a boat hits a turn mark – A Yellow Card penalty or other penalties may be applied.

If a boat destroys a buoy or cuts the securing line – A Yellow Card may be applied.

Missed Marks

Competitors may re-take a missed mark providing that in doing so they do not impede or endanger other competitors.

Where a competitor fails to retake a missed mark, they will be disqualified from that leg.

506.7.1 - STOPPING THE RACE

In case of force majeure or an accident, the race may be stopped by waving red flags. Red flags will be flown from official boats.

On seeing red flags, Competitors shall stop racing immediately.

In the event of the race being aborted by the use of the Red Flag procedure the finishing positions will be taken as at the passing of the last recorded turn mark.

Any boat deemed to be the cause or a contributory factor in the race being aborted will be disqualified.

Points will be awarded if the race has run more than minimum 70% of the course length, and/or the drivers have been racing for at least 1 hour.

506.7.2 - TIME LIMIT

The time limit applicable for boats finishing a marathon race should be based on an average speed of 25 knots.

Race Organisers must stipulate the maximum race time in Race Instructions which may, at their discretion, be longer than above.

The race may be curtailed or stopped at the finish line at any time by waving the briefed curtailment signal. This designates the end of the race.

506.8 - CLASSIFICATION TABLE

Class	Length as per UIM Measurement	Maximum HP	Minimum Number of engines	Minimum Weight (Kg per HP) Including fuel, equipment and Crew at end of race.
Super Marathon (A)	Min – 10m Max – 16m	Free	2	Cockpit 3 Kg/HP Open 4.0 Kg/HP
Grand Prix (C)	Min - 9m Max – 15m	1200 HP	2	Cockpit 3.50 Kg/HP Open 4.0kg/HP
Grand Sport (S)	Min -7.5m Max – 10m	600 HP	2	Cockpit 3.75 Kg/HP Open 4.25 kg/HP
Grand Touring (E)	Min -7.5m Max – 10m	450 HP	1	Cockpit 4 Kg/HP Open 4.50 kg/HP

All competing craft must be capable of exceeding 40 knots,

10% more engine capacity than the original installation is accepted. Classic Boats must be at least 25 years old from date of build.

506.9 - ULTRA MARATHON RACES

Ultra marathon races are defined as races where the total distance of one or more race legs exceeds 500 nautical miles.

Alternative Starting Procedure: For Ultra Marathon Races standing or near standing starts will be permitted instead of the procedure defined in Rule 305. Full details of this procedure will be included in race instructions and described at drivers briefing.

Safety requirements for organisers of Ultra Marathon Races

- a) The organisers must establish a central race control location from which a dedicated team can monitor the progress of boats via the boat tracker system.
- b) The organizer must also present risk assessment and an environmental risk assessment to the National Authority at least 90 days prior to the start of the race.
- c) The organisers must clearly define the financial implications applicable in the different countries should a boat have to be rescued or team members have to be transported ashore by rescue services.

Some long distance Marathon Races may require tracker systems, this decision will be made by the organisers prior to the event and details provided in the Advance Race Instructions.

For all Ultra Marathon Races a tracker system as defined by the race organizer is mandatory.

Satellite Telephone. For all Ultra Marathon Races where an area of the courses is out of range of VHF communications an operational satellite telephone must be carried on board at all times.

For Ultra Marathon races, the organisers must provide full details of the race entry fees and conditions.

507 - RULES FOR UIM RIB RACES

507.1 - GENERAL PRESENTATION

These rules have been established as guidelines for Offshore RIB power boat rallying/racing in open offshore seas. They provide the ability to compete in different weather conditions with safe rules designed to provide all competitors with a fair opportunity of winning with endurance as the main parameter, not only speed.

So that owners of the many different designs of RIBs may take part in competitive events in a standard, safe, fair and enjoyable manner.

To foster and develop a design of boat that is expressly built with massive inflatable buoyancy for safety and stability combined with an efficient hull for speed, practicality, comfort and pleasure.

To provide guidelines for National Authorities to be able to certify and assess compatibility RIB and conformity to participate in offshore RIB rallies/Races.

To discourage designs that compromise safety for speed.

It is preferable that boats should have the driver on wheel and throttle with the co-driver and navigator.

It is preferable that boats have standing seats position. But if racing seats are fitted, they should provide proper comfort and assure high, safe support to avoid back injuries.

All craft must be built to a certified standard to operate safely in Offshore waters.

Maximum engine capacity/HP is as declared by the Hull manufacturer.

This information may also be included on the Builders Plate.

507.3 - INTERNATIONAL RIB CLASSIFICATION – MONOHULLS ONLY

CLASS	RECREATIONAL MINIMUM	RECREATIONAL MAXIMUM	PRO MINIMUM	PRO MAXIMUM
RIB SPORT				
Hull Length	6 Metres	8.5 Metres	6.5 Metres	8.5 Metres
Engine HP	150 HP (Petrol) 240 HP (Diesel)	250 HP (Petrol) 350 HP (Diesel)	150 HP (Petrol) 240 HP (Diesel)	250 HP (Petrol) 350 HP (Diesel)
RIB SUPER-SPORT				
Hull Length	8 Metres	11 Metres	8.5 Metres	11 Metres
Engine HP	300 HP (Petrol) 650 HP (Diesel)	600 HP (Petrol) 700 HP (Diesel)	300 HP (Petrol) 650 HP (Diesel)	600 HP (Petrol) 700 HP (Diesel)
RIB OPEN				
Hull Length	8.5 Metres	13 Metres	8.5 Metres	13 Metres
Engine HP	- HP (Petrol) - HP (Diesel)	1000 HP (Petrol) 1200 HP (Diesel)	- HP (Petrol) - HP (Diesel)	1000 HP (Petrol) 1200 HP (Diesel)

INTERNATIONAL RIB CLASSIFICATION HAVE IDENTIFIED ANY BOAT WITH EITHER A STEPPED HULL OR A FOOT THROTTLE AS A PRO CLASS AND THEREFORE TO RUN WITH SAME POWER RECREATION CLASS AN EXTRA 0.5 KGM PER HP IS REQUIRED AS HANDICAP FOR PRO CLASS

In addition

- 1) Low emission engines should be used.
- 2) Recreation class = 3.5 kgms per horsepower
- 3) Pro-class_and Onboard engines = 4 kgms per horsepower
- 4) Minimum crew 2 - Maximum crew 4

507.3.1 - CLASS DEFINITIONS

PRO Class

Any RIB fitted with either a foot throttle, stepped hull, Canopy or special racing engine. Example: a 250 XS, 300R is a PRO series boat.

Recreational Class

Any RIB not fitted with a foot throttle or stepped hull and with no modifications to engine(s). No boats with canopies or restraints will be permitted.

507.3.2 - HANDICAPPING PURPOSE IF RACING 150 TO 250HP UNDER ONE CATEGORY SPORT AND 300 TO 600HP UNDER ONE CATEGORY SUPER SPORT

To allow different boats with different power and size to have equal chance of winning and competing for one prize.

All boats will be weighed post race and must be within class weights.

507.4 - ENGINES SPECIFICATIONS AND MODIFICATIONS

507.4.1.1 - TWIN INSTALLATION - OUTBOARD ENGINES

When twin engines of the outboard type are installed, but the particular type is not available with opposite hand rotation, it is permitted to modify the drive of one unit to opposite hand propeller rotation provided that:

The standard underwater casing is retained. The final propeller ratio to the crankshaft is unaltered.

507.5 - SPECIFIC RULES FOR BOATS AND EQUIPMENT

507.5.1 - COLOURS

All boats should not be complete white or blue or grey or black. If so, they should have stickers of phosphoric orange or yellow or red on both sides and on top visible from a distance by helicopter or large vessel.

507.5.15 - INFLATABLE COLLAR(S)

PVC, Hypalon, PU/PVC are accepted collar material. All materials should be of an approved Marine Fabric.

Minimum compartments accepted 3 independent.

The collar(s) is/are to be inflated to the proper pressure recommended by manufacturer for scrutineering.

And this pressure is to be maintained throughout an event, except under circumstances of force majeure only.

507.5.16 - HAND AND FOOT PUMPS

A hand or foot pump capable of inflating the tubes and being operated below the gunwale shall be carried.

507.5.23 - VHF/GMDSS RADIOS

Each boat must carry at all times whilst racing; a hand held VHF radio or a fitted 25 watt radio each of which must be 'certified waterproof by the manufacturer'.

507.5.24 - BILGE PUMPS AND BAILERS

All boats should have the deck completely isolated from the hull and should be at least 5cm above the waterline with maximum loaded weight. Only 1/4 of deck can be below the water line.

For all boats participating in offshore rallying. As boats are sometimes more than 10 nm from shore, they are subject to high waves and might be completely submersed and thus should have a self-bailing system which is not dependent on mechanical or electrical systems. Extruder 50cmx50cm capable of extracting all deck water when moving at minimum power to dry the deck in a maximum of 3 minutes, as per CE marking regulation for class B vessels is acceptable.

A satisfactory bailing device, either automatic or electric, shall be fitted. In addition, a manual backup, either a bailer or bucket must be provided.

507.5.26 - FLARES AND MARKERS

A minimum of 2 red parachute or rocket flares, 2 red location flares and 2 orange smoke flares are recommended. All flares shall be stowed in a conveniently accessible place, shall bear either the date of manufacture or the expiry date in original manufactured form, not handwritten.

507.6 - ASSISTANCE RULES

The orange flag is to be displayed where a vessel requires assistance or has retired. Unless another vessel is already rendering assistance it is the responsibility of each racing boat to investigate the situation where either:

- a) an orange flag is displayed or
- b) another race boat is stopped and making no signals.

507.10 - RIB RACING COURSE RULES

For Grand Prix, International Championships, Rally, or offshore marked course

Minimum short leg course length is 40 nm. In the case of a circuit, the length of a lap multiplied by the number of laps should be equal to over 40 nm to be equivalent to the Rally course and the races that run from port to port.

Minimum one long leg of a course to be over 60 nm.

Maximum accepted total course length per day is 200nm.

An event with a Total of 1 leg to be over 100 nm and maximum 150 nm.

An event with a Total of 2 legs to be over 100 nm and maximum 300 nm.

An event with a Total of 3 legs to be over 140 nm and maximum 450 nm

An event with a total of 4 legs to be over 200 nm and maximum 400 nm.

Ultra-Long Rib Course – Over 450 nm

A Rest Day must be taken when the competitors have raced for 4 Days or have traveled a distance of 450 nm.

Distances for following legs is as the above table showing Legs 1 to 4.

GROUP 600 RECORDS AND PERFORMANCES

600 - RECORDS AND PERFORMANCES

600.01 - GENERAL

All record trials and their control subscribe to the following rules.

The record belongs personally to the driver who has established or beaten it. The record is entered under the name and nationality of the driver.

Any race against the clock and called kilometre or mile trials or any similar name is prohibited if not conducted in accordance with these rules.

Combining speed records with distance records is not allowed.

No direct or indirect aid is to be provided to the driver who attempts a record.

600.02

World speed records, hour records, distance records and competition records are all records open to all boats and aquabikes of international classes adopted by the UIM

600.03

National records recognised by UIM are the records established by boats of National classes duly recognised by the National authority (the rules of which have been approved by the UIM). The Certificate differs from those issued for World Records.

600.04

The World's Unrestricted Water Speed Record is awarded to the fastest boat in the world piloted by the driver, irrespective of the class of boat; this record is established in conformity with the UIM rules.

601 - CLASSES ELIGIBLE FOR RECORDS

601.01

World records may be attempted with the following craft :

- All UIM series and classes;
- American Powerboat Association classes;
- Prototypes.

601.02

A boat can only establish a record in its own class.

601.03

When a class is modified so as to reduce the performance of the class, for example by :

- reducing the cylinder capacity;
- restricting the tuning permitted;
- restricting fuel permitted;
- introducing a minimum weight;
- increasing the minimum weight;
- or any other means;
- the records established before the modification comes into force will be frozen and a new series of records will be started;

All proposals for new rules, rule changes and UIM General Assembly minutes shall state :

- whether or not records will be frozen;
- the classes to be frozen;
- the date(s) when the classes are to be frozen.

601.04 - QUALIFICATION

For offshore records, a boat must have completed the course, taken the chequered flag and finished first, second or third, in a UIM World or UIM Continental Championship race in the class to be attempted, and after the date when the class was last frozen.

602 - DEFINITION OF UNITS**602.01 - TIME, DISTANCE AND SPEEDS**

The hour is the twenty-fourth part of a terrestrial day. The symbol is letter "h". The minute of time is the sixtieth part of one hour. The symbol is letters "mn"; The second of time is the sixtieth part of one minute. The symbol is the letter "s".

Nautical mile	=	nm
statute mile	=	st.m
kilometre	=	km
Nautical mile per hour	=	knot
statute mile per hour	=	mph
kilometre per hour	=	kmh

602.02 - STATUTE MILE, NAUTICAL MILE AND KILOMETRE

The statute mile is an Anglo-Saxon measure.

The Nautical mile is used at sea.

The knot is not a unit of length; it expresses the speed of one nautical mile per hour. One

statute mile (st.m) = 5280 feet = 0.8690 nm = 1,609.3 km

One nautical mile (nm) = 6080 feet = 1,852 km = 1.1508 st.m

One kilometre = 3280.844 feet = 1000 metres

604 - BASES (THE COURSE)

604.01

Records may only be established on bases recognised by National Authorities and notified to the UIM in accordance with these rules.

604.02

The base is measured and certified by an official surveyor holding a certificate of competence from a recognised institute, in the presence of a delegate of the National Authority.

The base must be measured by triangulation or electronic distance measuring equipment (EDM), which must have a first class certificate delivered by an Observatory or similar authority. This certificate must not be older than two years.

The official surveyor provides a certificate in duplicate in which the strict adherence to the above requirements is certified.

The certificate is signed by the surveyor and countersigned by the delegate of the National Authority. One of the copies is for retention by the National Authority for its special National records files and the other is sent to UIM for its special World record files.

The base for a record must be a fixed base, as laid out for a National Authority, or must be measured for a special occasion in waters designated by the driver. It must be defined by fixed marks ashore.

604.03

No distinction is made between records established on the sea, rivers or lakes. Records must not be attempted during the period between half an hour before and half an hour after a change in direction in flow of water over the course (change of tidal flow).

604.04

Any expenses incurred in the laying of a temporary course are defrayed by the entrant attempting the record.

604.05

For speed records there shall be only one attempt on the course at any one time. An attempt must not start until the Officer Of the Day of the trial is satisfied that effective rescue boats are on the course.

605 - CALCULATION OF SPEED

605.01

The National Authority calculates the speed from the data provided by timekeepers. The speed is to be shown in kilometres per hour (kph) and statute miles per hour (mph), even when the attempt takes place on a course of one nautical mile.

The duration of each run is obtained by taking the arithmetical mean of the times recorded by two sets of timing devices, the mean time being given to one tenth of a second.

Should one of the timing devices stop or one of the signals fail and only one duration be registered, this duration will be accepted.

605.02

The only duration so obtained serve to calculate the speed of each run. Only two decimal places are to be used.

605.03

The speed of the trial is the arithmetical mean of the speeds, two decimal places being used.

605.04

For speed records established on a distance of one nautical mile (1 nm = 1.852 km = 1.1508 st.m) the following constants are to be used :

Where t is the time in seconds :

the speed in mph = $4142.9 \div t$

the speed in kph = $6667.2 \div t$

606 - MARGIN REQUIRED

A record will be valid only if its speed at least equals the speed of the previous record multiplied by 1.003.

607 - MOTORS

607.01

All accessories and/or elements required by the racing rules for each class of boat attempting to establish or improve a record must be on board during said attempt.

607.02

A boat which holds two certificates for two different classes is entitled to establish World records in those two classes, but shall make two distinct trials, one for each class.

607.03

Immediately after the record trial, the motor(s) or engine(s) must be sealed with a distinctive seal in the presence of the officials who have witnessed the trial.

607.04

Within 48 hours of the trial, two measurers must check that the hulls, motors and equipment are in conformity with the specifications of their class, and this inspection must be carried out in the presence of the Officer of the Day or an Official specifically appointed by the National Authority.

607.05

When attempting to break a UIM class record, the noise level of the motor shall not exceed the authorised level (rule 735.14).

608 - REQUEST TO ORGANISE**608.01**

All applications for records trials must be made in writing to the National Authority at least one week before the trial and must be accompanied by the fee stipulated by the National Authority.

The National Authority applies to the UIM for homologation of records.

608.02

Only records established under the direct control of a National Authority affiliated to the UIM can be recognised.

608.03

Each National Authority decides on the application for records to be established on its territory. The National Authority may refuse to consider a record application but must then explain the reasons in writing.

The National Authority indicates the validity of the record permit.

608.04

It is the duty of the driver to accept responsibility for any safety measures deemed necessary for this attempt.

The Officials will not accept any responsibility, they will only record the results and ensure that the rules are complied with.

609 - OFFICIALS**609.01**

The National Authority shall appoint an Official Observer and other duly qualified persons to hold the official functions.

An Official so nominated shall not hold any other office than that to which he/she was nominated. An Official shall not himself establish a record.

609.02

The Official Timekeepers and Officials may receive payment for their services at rates fixed by the National Authority.

609.03

Time keeping may only be carried out by Timekeepers and Officials who have been recognised and authorised by the appropriate National Authority.

The stopwatches or any other apparatus employed must have a first-class certificate delivered by an observatory or similar authority. This certificate must not be older than two years.

Each Timekeeper hands to the National Authority a signed report of the record attempt, countersigned by the Official Observer.

609.04

Timing from aboard anchored boats or aboard competing boats is not allowed.

610 - SPEED RECORDS

Please refer to section 610 under Offshore Rulebook

611 - DISTANCE RECORDS

611.01

Distance records are established on a total course of twelve nautical miles for the outboard series, twenty-four nautical miles for other series, and six nautical miles for aquabikes.

611.02

In distance records, the base is covered up and down successively in even numbers and the turns are not included in the distance.

The course for distance records may be :

- a course established for speed records;
- a base of three nautical miles maximum, in straight lines with buoys placed at the corners if necessary, no corner to be less than 135 degrees.

The buoys placed at the corners must always be rounded.

611.03

Any base must be defined by two posts set in concrete at either end.

611.04

Timing is to be to one tenth of a second.

The timing of distance records is done by a Timekeeper with two timing devices at the starting line. He/she is assisted by two Officials, one with him and one at the other end.

611.05

Stopping the motor or the boat during a distance record attempt is prohibited.

612 - HOUR RECORDS

612.01

The following International and National records are recognised by the U.I.M : 1, 2, 3, 4, 6, 9, 12 and 24 hours duration records for all the series recognised by the UIM

The homologation of a record of lesser duration than that applied for may be granted, but only within such limits as provided for by the above rule.

612.02

The base must not exceed six nautical miles from station to station, which is to say twelve nautical miles up and down. For aquabikes only, the distance may be 3 nautical miles from station to station, which is to say 6 nautical miles up and down.

612.03

The base is defined by two posts set in concrete at either end.

612.04

The boat may be driven by more than one driver, but their name must be filed in the record application.

612.05

Repairs and adjustments which can be carried out on board may be effected on the course.

The same engine(s) and hull must be used throughout the trial.

On the other hand, repairs that cannot be effected on board and refuelling and changing of drivers must be effected at the control station and are to be supervised by an Official.

612.06

Any time during which a boat stops during an attempt is included in the elapsed time for the attempt.

Turns are included in the course and are consequently not excluded from the timing.

612.07

Timing is carried out by one or several Timekeepers with two timing devices stationed at the start. The Timekeeper is assisted by two Officials, one stationed with him and one stationed at the other end.

612.08

A driver can claim several different hour records during one trial by selecting the best series of consecutive laps.

612.09

The boat must cross the finishing line at the end of the lap (the last lap) during which the record time has elapsed.

The average speed of the last lap is calculated and the distance which corresponds to the time still to be run is added to the distance covered at the end of the penultimate lap.

The result is shown as the distance covered in the record time and the average speed for that distance.

612.10

Example for a two hour record on a base of six nautical miles (nm), twelve nautical miles per lap :

boat completes 8 laps	in 1 h 54 mn 40 s	= 110.48 st.m
ninth lap completed	in 13 mn 50 s	= 830 s
time balance	5 mn 20 s	= 320 s
distance balance	= 13,81 st.m ÷ 830x320	= 5.32 st.m
Total distance in 2 h	= 115.80 st.m	
Average speed	= 115.80 ÷ 2	= 57.90 mph

613 - WORLD COMPETITION RECORDS**613.01**

The UIM recognises World records of 5, 10 and 15 statute miles in races for all UIM circuit classes.

No other records may be established during a race.

Unlimited hydroplanes only are entitled to statute mile records established on :

- a single lap course (two laps for APBA Gold Cup races) while qualifying or racing;
- total heat average speed while racing;

614 - PERFORMANCE CERTIFICATES**614.01**

The UIM may issue Performance Certificates for the best heats made during races for the principal International trophies.

614.02

Application for these is to be made by the National Authority of the Country where the race took place and the accuracy of the results, timing, course and class is to be certified by them.

614.03

The UIM only recognise the results which improve upon previous performances.

614.04

The amount of the fee for a Performance Certificate is decided upon annually by the General Assembly.

614.05

The UIM may issue a Performance Certificate for speed trials made by boats not included in UIM classes. These trials must, however, be made in accordance with UIM rules.

The UIM award Performance Certificates for boats of the Production Boat Series having established or broken speed, duration, distance or competition records according to the Record Rules.

614.06

For these performances, it is not permissible to remove any of the boat's accessories, or items of comfort, provided by the builder and these are compulsory for racing.

The UIM may award Performance Certificates for any of the offshore classes, International and National, established at sea on properly measured runs.

615 - HOMOLOGATION OF RECORDS**615.01**

Only records homologated by the UIM are considered as World Records.

Only records established under the direct control of a National Authority affiliated to the UIM can be recognised.

615.02

If a record has been established on the territory of two National Authorities, it will be entered as a record by the National Authority on whose territory the start was made.

As soon as a record trial has taken place, the National Authority shall communicate the results to the Secretary General of the UIM by fax and confirm it by letter.

The information has no official character and is only transmitted to such National Authorities as apply for it, in order to avoid useless trials.

615.04

The Timekeepers and Measurers must complete the official UIM record application form, which must be signed as correct by the Senior attempt Official (President, Chairman, Officer Of the Day etc.) and be sent to the National Authority within three days of the trial, (seven days for APBA controlled classes).

The National Authority transmits the application for homologation, together with other necessary papers, to the UIM no later than four weeks after the trial, (sixteen weeks for APBA controlled classes).

615.05

For a request for homologation to be considered by the UIM, the National Authority must send :

- a plan of the course if not already in possession of the UIM;
- the completed official UIM application form which must include any National Authority calculations;
- a copy of the boat's measurement certificate;
- to be noted on the reverse, the driver's name, class and speed achieved;
- a list of the full names of the Officials with, at least, the names of the Timekeepers, Measurers, Rescue Officer, Officer Of the Day and Observer;
- e results in which the boat qualified, as per UIM rule 601.04;
- for attempts on tidal waters, the calculation stating the times of the changes of direction of water along the course (changes in tidal flow) and the source of the information;
- a cheque for the amount due.

615.06

The recognition fee is fixed annually by the General Assembly.

615.07

Pending the official confirmation by the UIM, neither the driver, builder, nor any other party shall publish or cause to be published, circulate or cause to be circulated, the results of the trial, until the delegate of the National Authority has given the actual results in writing, after checking the calculations in the presence of Timekeepers.

Even when such authorisation has been received, results may only be published with the addition of the words "Subject to official ratification by the UIM in as large and prominent type as that in which any part of the notification itself is printed.

Neglect to comply with the above regulations automatically entails the refusal to recognise the record. The National Authority has the right to penalise whoever is responsible.

615.08

The UIM issues annually a list of World records, changes being made known, when they occur, by means of newsletters.

The UIM keeps a registered list of all World records and delivers a certificate for each new record.

616 - UIM RULES FOR LONG DISTANCE OFFSHORE MOTORBOAT WORLD SPEED RECORDS

General - This edition of the rules supersedes the existing rules.

616.01 – AUTHORITY

The UIM through the relevant National Authority is the authority in all matters concerning Long Distance records. It co-operates with National motorboat authorities as appropriate but is also able to examine and ratify record claims made by individuals and to approve attempts when they fall outside of the jurisdiction of a UIM national authority.

616.01.1 - LICENCE

All persons attempting a Long Distance record must hold a competition licence issued by their national authority.

616.01.2 – First Aid

Both driver and co-drivers/navigator must hold a first aid certificate with resuscitation knowledge, it is recommended that all other crew also hold such a certificate.

616.01.3 – VHF

The Radio Operator must hold a VHF Operators licence, it is recommended that at least one other crewmember hold such a licence.

616.01.4 - SEA SURVIVAL CERTIFICATE

A current sea survival certificate must be held by all crew members.

616.02 – RATIONAL**Records and races**

Elapsed times achieved in motorboat races organised by clubs which are recognised by a National motorboat authority are accepted as correct by the UIM/relevant National Authority. The shortest time, without handicap, is the record for an event. A record achieved during a race is listed as a race record and an outright record. If, however, an individual performance over the same course betters a race and outright record, it will only be listed as an outright record.

Records will be recognised for passage between pre-determined points providing all relevant rules for independent observation are established, maintained and ratified.

Racing rules

The UIM racing rules do not apply during individual (non-race) record attempts.

616.03 - GENERAL

The purpose of the rules is to enable attempts to be made on a variety of offshore records. They do not form the conditions of any prize or trophy, nor are they motorboat instructions.

The record for each passage shall stand until the elapsed time of that record has been reduced by at least one minute. Every request to ratify a record shall be considered in time and date order.

The time used for this purpose will be Greenwich Mean Time.(GMT)

The UIM/relevant National Authority cannot accept any responsibility for personal injury or loss of life, damage to or loss of property arising from any record attempt made under its rules whether supervised by its officials or not.

The official language is English.

616.04 - LONG DISTANCE OFFSHORE WORLD RECORDS

The World Record for the passages listed in rule **616.10** will be held by the Motorcraft and skipper which establishes the shortest elapsed time in accordance with these rules.

Any offshore record can be held in either of the following categories:

- Any vessel in excess of **3 meters** and less than 50 **meters** LOA, with any number of crew.
- A vessel / **support vessel** can only operate in **conditions** / areas which it **is** rated for under its design category as per its Builders Plate
- Maximum Number of crew for which it rated for under its design category as per its Builders Plate
- It is not allowed to do any records single-handed that require duration longer than 6 hours.

All records are be divided into **four** outright classes,

- 1) Up to **16ft/4.88 meters LOA,**
- 2) **Over 16ft/4.88 meters and up to** 30ft/9.14 metres LOA,
- 3) Over 30ft/9.14 metres LOA and up to 50ft/15.24 metres LOA
- 4) Over 50ft/15.24 meters LOA,

To be measured using **relevant UIM Class Rules** or the method for Offshore Class I. Any of the above classes could also be eligible for the fastest outright record. (For example : a skipper may apply for the Up to 30 ft record, but if he beats the existing outright time, then he would also be eligible for the outright record).

“Without assistance” - means that a vessel may not receive any kind of outside assistance or take on board any fuel supplies, materials or equipment during a record attempt. A craft may be anchored or beached during the record attempt but any repairs must be made entirely by the crew without outside resources or materials.

“With assistance” - means a vessel may enter harbour for fuel, repairs, alterations or stores as required. Crew, excepting the skipper, may be changed. During any stops, the timing of the voyage continues.

It is never permitted to take on board fuel stores or equipment or get any other kind of help from another vessel whilst under way (except as permitted by 616.05 6 Emergencies).

***Vessels in the category up to 16ft/4.88 meters LOA must be accompanied by a support craft which has the ability to provide emergency assistance within a reasonable timeframe.
The support vessel must be of a suitable type and equipped to provide support to a smaller vessel in distress and to recover an unconscious person from the water.***

616.05 - MOTORBOAT RULES

Applies to all long distance offshore records and all types of vessel.

Propulsion - any method of mechanical force.

Steering - any type of automatic steering is allowed.

Navigation - any type of navigation equipment is allowed and there is no objection to any type of information or advice being transmitted to or from the vessel. However, the vessel must be driven and navigated by the onboard crew.

Emergencies:

In the event of the record attempt being diverted or compromised by the necessity to render assistance to a mariner in distress (excluding members of the record crew), time allowances may be made subject to the provision of adequate documentary and substantive evidence of time lost.

In the event of fouling another vessel or manned structure (e.g. an oil rig) it is permitted for the crew of the other vessel or structure to assist the vessel in getting clear.

Rounding - when a course calls for a mark, beacon or point of land to be 'rounded', this means that an imaginary string from the start to the finish points must enclose the feature specified when pulled tight.

Tidal stream or current - no allowance is made for tidal stream or current in considering any of these records.

Refuelling - must not be done by another vessel whilst at sea. Recognised fuel outlets within harbour confines are acceptable.

Responsibility - It is the sole and inescapable responsibility of the skipper of a motorboat engaged in any such record attempt to decide whether to start and, having done so whether to continue the voyage.

the Vessel - shall have communication equipment capable of maintaining contact throughout the attempt with monitoring stations along the route.

Life-raft - a certified life-raft or life-rafts suitable for the maximum number of persons on board shall be carried along with the full safety equipment appropriate for the planned passage.

Tow - when a tow is received, the attempt shall return to the last official recorded "own power" position before resuming. If a "without assistance" boat receives a tow the attempt then fails or becomes "with assistance."

616.06 - SAFETY RULES

It is not within the province of these rules to set safety standards. However, all vessels making record attempts must comply with the appropriate safety standards enforced by International Maritime Law and by their Country of origin or registration, and of any race or trophy in which they may be competing, and by the country in which home waters they are sailing. In addition, the relevant rules regarding personal flotation devices, helmets, restrained driver and crew (FHR, air systems, restraint belts, seats, etc.) have to be complied with. Evidence of compliance must be provided to the relevant National Authority prior to departure.

616.07 - NOTICE

At least one month's notice be given of intended record attempts, accompanied by the appropriate fee, otherwise the relevant National Authority cannot guarantee to observe a record. Records cannot be recognised retrospectively.

616.08 - OBSERVATION / DECLARATION

When proper notice of a record attempt has been received, the relevant National Authority will appoint an observer to make arrangements for the start and finish to be witnessed and timed. The observer or a person appointed by him, will also need to check that the documentary evidence provided relates to the vessel that has completed the record passage. The skipper and one other member of the crew will be asked to sign a declaration that all the rules have been followed. Where practicable, there is no objection to the observer being on board during the record attempt.

616.09 - TIMING

The moment of starting and finishing a record passage must be recorded to the nearest second using GMT. The accuracy of these must be checked within six hours of the start and finish of the attempt by reference to an official time signal by telephone or radio. Details of the timepiece used must be logged and signed for by the observer or his/her appointee.

Records will always be defined as an elapsed time in days, hours, minutes and seconds. Average speed may be shown for information only.

616.10 - RECORD COURSES

General

Only fixed points of land, fixed navigational beacons or other charted fixed objects can be used as reference points though they need not necessarily be sighted. In special cases, pre-approved by the Observer, such as positions derived from satellite navigation systems are acceptable.

All routes are reversible and the record time from A to B can be beaten by an attempt from B to A.

If a new route is requested then an application from a National Authority to the UIM is required. This application can be submitted to the UIM at any time during the year however all applications must be made no later than 90 days prior to the intended record attempt. Provided that the new route does not conflict with a very similar existing route it will be approved.

The application should detail Points A @ B, and the Distance in Kilometres, Statute Miles and Nautical Miles. No Long Distance Record Course can be less than 50 Statute Miles – 80 Kilometres.

The start and finish positions are given as Points A and B.

When a tow or other outside assistance is obtained, the attempt shall return to the last officially recorded "own power" position before resuming.

Specific details of the Record Course been attempted must be acquired from the relevant UIM National Authority.

Abu Dhabi - Doha Sheraton Hotel (Gulf route)

The established distance is 309 Kilometres / 193 Statute miles / 167 Nautical miles.

Point A: Abu Dhabi Marina

Point B: Doha Sheraton Hotel

Aden to Jeddah, Saudi Arabia

The established distance is 1272.32 Kilometres / 790.585 Statute miles / 687 Nautical miles.

Point A: a line 1 Nm due South of Aden No.1 buoy (12° 44.490'N 44° 56.830'E)

Point B: a line 1 Nm due West from South Cardinal No. 6 (21° 27.240'N 39° 02.820'E)

Around the World

The established distance is 43516.44 Kilometres / 27038.9 Statute miles / 23,497 Nautical miles.

To make motorised passage around the World, eastbound or westbound, a vessel must start from and return to the same point, must cross all meridians of longitude, and must pass through the Suez and Panama Canals. Further records may be applied for and set between ports of passage or recognised points if they are contained within an overall record for circumnavigation. Full details of the proposed passages must be submitted with the application.

Bahia de Fajard, Puerto Rico - Gibraltar

The established distance is 6269 Kilometres / 38.95.4 Statute miles / 3385 Nautical miles.

Point A - 1 Nm line due South of Europa Point Lighthouse, Gibraltar (36° 06.575'N 005°20.690'W)

Point B - 1 Nm line North South through the safe water mark off Bahia de Fajard Approximately (18° 23.000' N 65° 34.250' W).

Bahia de Fajard, Puerto Rico - Colon, Panama

The established distance is 1879.8 Kilometres / 1168 Statute miles / 1015 Nautical miles.

Point A - entrance of Panama Canal - 1 Nm line East West through the safe water mark off Port of Manzanillo (18° 18.500' N 100° 31.375' W)

Point B - a 1 Nm line North South through the Safe Water mark at the Eastern entrance of the canal.

Bahia de Fajard, Puerto Rico - Port of Manzanillo, Mexico

(including transiting the Panama Canal)

The established distance is 5157.82 Kilometres / 3204.9 Statute miles / 2785 Nautical miles.

Point A - a 1 Nm line North South through the safe water mark off Bahia de Fajard (18° 23.000' N 65° 34.250' W)

Point B - a 1 Nm line East West through the safe water mark off Port of Manzanillo (18° 18.500' N 100° 31.375' W)

Bermuda - Hatteras North Carolina

The established distance is 1051.9 Kilometres / 653.6 Statute miles / 568 Nautical miles.

Point A - Gates Fort on Town cut Channel 32° 20.3' North 64° 40' West.

Point B - Hatteras Lighthouse starting Due East within 1/2 mile off shore 35° 15' North 75° 30.5' West

Cork Harbour - Fastnet Rock - Cork Harbour.

The established distance is 213.4 Kilometres / 132.6 Statute miles / 115.2 Nautical miles.

Point A/B line at Cork Harbour is between Weavers Point and Roches Point lighthouse.

Cork Harbour – Dun Laoghaire

The established distance is 279.09 Kilometres / 173.4 Statute miles / 150.7 Nautical miles.

Point A – a line at Cork Harbour is between Weavers Point and Roches Point lighthouse.

Point B - a line directly North of East Pier Lighthouse 53° 18.145'N, / 006° 07.6198'W TO 53° 18.430'N, / 006° 07.6198'W

Cork Harbour – Jersey

The established distance is 335.3 statute miles (291.4 nautical miles), (539.7 kilometres).

Point A: Cork Harbour – The Start/Finish is a line between Weavers Point and Roches Point lighthouse.

Point B: Jersey – The Start/ Finish Line is a line South of Noirmont Point Lighthouse (49° 9.909'N, / 002° 10.084'W) to Les Fours North cardinal mark (49° 9.551'N, / 002° 10.088'W)

Dun Laoghaire (Dublin Ireland) - Douglas (Isle of Man)

The established distance is 143.9 Kilometres / 89.42 Statute miles / 77.7 Nautical miles.

Point A - a line directly North of East Pier Lighthouse 53° 18.145'N, 006° 07.6198'W

Point B - A line directly West of Marine Drive Toll Gate 54° 08.443'N, 004° 28.242'W to 54° 08.443'N, 004° 27.770'W

Douglas (Isle of Man) - Holyhead (Isle of Anglesey)

The established distance is 90.7 Kilometres / 56.4 Statute miles / 49 Nautical miles.

Point A - a line directly East of Marine Drive Toll Gate 54° 08.443'N, 004° 28.242'W to 54° 08.443'N, 004° 27.770'W

Point B - A line directly of North of Breakwater Lighthouse 53° 19' 51.56 N, 004° 37' 9.22W

Holyhead (Isle of Anglesey) - Dun Laoghaire (Dublin Ireland)

The established distance is 100.4 Kilometres / 62.4 Statute miles / 54.2 Nautical miles.

Point A - A line directly of North of Breakwater Lighthouse 53° 19' 51.56 N, 004° 37' 9.22W Point B - Dun Laoghaire

Harbour – a line directly North of East Pier Lighthouse 53° 18.145'N, 006° 07.6198'W

Galle, Sri Lanka - Mangalore, India

The established distance is 1018.6 Kilometres / 632.93 Statute miles / 550 Nautical miles.

Point a - 1 Nm line North South of the Fairway buoy (06° 00.550'N 80° 13.260'E)

Point B - 1 Nm line due West of Fairway buoy (12° 54.880'N 74° 44.290'E)

Hatteras North Carolina - New-York Harbour

The established distance is 600 Kilometres / 372.9 Statute miles / 324 Nautical miles.

Point A - Hatteras Lighthouse starting Due East within 1/2 mile off shore 35° 15' North 75° 30.5' West

Point B - The traditional New York starting point is Ambrose Light Tower, (no longer there). Use Buoy C1 marking channel to Liberty Landing Marina 40° 42.4' North and 74° 0.2' West

Huntington Beach – Around Catalina – Huntington Beach

The established distance is 174.2 kilometres / 108 statute miles / 94 Nautical miles.

Point A/B - a line 33°39'11.20"N - 118°0'22.43"W / 33°39'5.69"N - 118°0'28.08"W

Ireland - Iceland

The established distance is 1378.25 kilometres / 856.41 statute miles / 744.2 Nautical miles.

Point A - a line due East from Killybegs Town Pier (54.633159N, 08.443823W)

Point B - a line from Orfirsey Pier (64.159841N, 21.929112W) to Engey Lighthouse. (64.174967N,21.924507W)

Jeddah - Southern entrance of Suez Canal

The established distance is 5093 Kilometres / 3164.64 Statute miles / 2750 Nautical miles.

Point A - A 1 Nm line due West from South Cardinal No. 6 (21° 27.240'N 39° 02.820'E)

Point B - A line between the 161 km markers at (29° 55.880' N 32°33.825' E)

Key West - Cuba

The established distance is 166.7 Kilometres / 103.6 Statute miles / 90 Nautical miles.

Point A - KEY WEST: N24°33.529' / W081 °48.886' Degrees Lat Long 24.5588167°, -081.8147667° Degrees Minutes Seconds 24°33.52900', -081 °48.88600' Degrees Minutes Seconds 24°33'31.7400", -081°48'53.1600"

Point B - CUBA: N23°08.902' / W082°21.542' Degrees Lat Long 23.1483667°, -082.3590333° Degrees Minutes Seconds 23°08.90200', -082°21.54200' Degrees Minutes Seconds 23°08'54.1200", -082°21'32.5200"

Leon Guerrero, Guam - Port of Singapore, Singapore

The established distance is 5093 Kilometres / 3164.6 Statute miles / 2750 Nautical miles.

Point A - 1 Nm line East West through the safe water mark off the entrance to Jose D Leon Guerrero Harbour (13° 27.500' N 144° 36.800' W)

Point B - The entrance to Marina Bay harbour – A line between S Marina yellow mark (01° 16.700'N 103° 52.365'E) and S Kallang yellow mark (01° 16.820'N 103° 52.600'E)

London - Monte Carlo

The established distance is 3850 Kilometres / 2392 Statute miles / 2080 Nautical miles.

Point A - a line at London to be between Royal Pier, Gravesend and Tilbury Fort.

Point B - a line at Monte Carlo to be due east of the Yacht Club de Monte Carlo.

Malta - Gibraltar

The established distance is 1870.52 Kilometres / 1162.29 Statute miles / 1010 Nautical miles.

Point A - a line between Saint Elmo light North side of harbour arm of Valetta harbour and the Valletta Fairway buoy (35° 54.715'N 14°32.506'E)

Point B – a 1 Nm line due South of Europa Point Lighthouse, Gibraltar (36° 06.575'N 005°20.690'W)

Mangalore, India - Port Salalah, Oman

The established distance is 2277.96 Kilometres / 1415.46 Statute miles / 1230 Nautical miles.

Point A - a 1 Nm line due West of Fairway buoy (12° 54.880'N 74° 44.290'E)

Point B - a 1 Nm line due North of Safe water mark (16° 56.890'N 54° 04.400'E)

Marseille, France - Carthage, Tunisia

The established distance is 842.7 Kilometres / 523.6 Statute miles / 455 Nautical miles.

Point A - a line due east from Pomegues Lighthouse (43 15.7N, 5 17.4E).

Point B - a line drawn due east from Ras Quartajamah Lighthouse (Cape Carthage, near Sidi Bou Said, 36 52.3N, 10 20.9E).

Messina – Vulcano – Messina Record Course:

The established distance is 120.38 Kilometres / 74.8 Statute miles / 65 Nautical miles.

(Torre Faro) – A – B – C (Vulcano Island - Intermediate Time) – D – B – A – (Torre faro)

Point A/B: 38° 15.815'N – 15° 39.200' E

A - 38° 16.270'N – 15° 39.415' E

B - 38° 18.625'N – 15° 33.045' E

C - 38° 21.510'N – 14° 59.660' E

D - 38° 21.610'N – 14° 59.690' E

Monaco – Malta

The established distance is 1123.11 Kilometres / 697.87 Statute miles / 607.37 Nautical miles.

Point A - a line at Monte Carlo to be due east of the Yacht Club de Monte Carlo.

Point B - a line at Dragonara, St Julian's between 33 55.60N / 014 29.73E and 35 56.63N / 014 31.36E

Monaco - Round Corsica /Sardinia - Monaco

The established distance is 1263 Kilometres / 785 Statute miles / 682 Nautical miles.

Point A / B - A line at Monte Carlo to be due east of the Yacht Club de Monte Carlo.

New York Harbour - Bermuda

The established distance is 1224.2 Kilometres / 760.7 Statute miles / 661 Nautical miles.

Point A - The traditional New York starting point is Ambrose Light Tower, (No Longer there) use Buoy C1 marking channel to Liberty Landing Marina 40° 42.4' North and 74° 0.2' West

Point B - Gates Fort on Town cut Channel 32° 20.3' North 64° 40' West.

North Atlantic Crossing (Killybegs, Ireland to St. John's, Canada.)

The established distance is 3237.3 Kilometres / 1949.4 Statute miles / 1694 Nautical miles.

Point A - a line due east (true) from Killybegs Town Pier (54.633159, 08.443823W)

Point B - a line between North Head (47.566415N, 52.677708W) and Fort Amherst Lighthouse.

Pacific exit of Panama Canal - Port of Manzanillo, Mexico

The established distance is 3222.48 Kilometres / 2002.36 Statute miles / 1740 Nautical miles.

Point A - 1 Nm line North South through the Safe Water mark at the Western entrance of the canal

Point B 1 Nm line East West through the safe water mark off Port of Manzanillo (18° 18.500' N 100° 31.375' W)

Palm Beach (Florida, USA) - West End (Grand Bahamas, Bahamas)

The established distance is 103.00 Kilometres / 64.00 Statute miles / 55.61 Nautical miles.

Point A - Palm Beach Inlet (26°46'20.00"N 80° 1'54.00"W)

Point B - West End ,Crossing 79th Meridian West South of 26°41'30.00"N

Poole, England – Cherbourg, France:

The established distance is 115.8 Kilometres / 71.96 Statute miles / 62.53 Nautical miles.

Point A -a line at Poole between the Branksome Chine Outfall Buoy, 50° 42.21 'N, 01° 54.23 'W, to the brick building on the beach,

Point B - a line at Cherbourg is the midpoint (49° 40.39 'N, 01° 39.42 'W) of the transit line between the breakwater ends of the Western entrance to Cherbourg outer harbour.

Port of Manzanillo, Mexico – Honolulu Harbour, Hawaii

The established distance is 5556 Kilometres / 3452.3 Statute miles / 3000 Nautical miles.

Point A - a 1 Nm line East West through the safe water mark off Portof Manzanillo (18° 18.500' N 100° 31.375' W)

Point B - a 1 Nm line North South through the safe water mark off Honolulu Harbour (21° 18.250' N 157° 58.000' W)

Port Said, Egypt - Gibraltar

The established distance is 3555.84 Kilometres / 2209.49 Statute miles / 1920 Nautical miles.

Point A - The line between the No 5 Buoys at (31°19.130'N 32°22.100'E)

Point B - A transit line due South of Europa Point Lighthouse, Gibraltar (36° 06.575'N 005°20.690'W)

Port Said, Egypt - Valetta, Malta

The established distance is 1759.4 Kilometres / 1093.24 Statute miles / 950 Nautical miles.

Point A - a line between the No 5 Buoys at (31°19.130' N 32°22.100' E)

Point B - a 1 Nm line between Saint Elmo light North side of harbour arm of Valetta harbour and the Valletta Fairway buoy (35° 54.715' N 14°32.506' E)

Port of Singapore, Singapore – Salalah, Oman

The established distance is 5926.4 Kilometres / 3682.49 Statute miles / 3200 Nautical miles.

Point A - The entrance to Marina Bay Harbour. The line between S Marina yellow mark (01° 16.700'N 103° 52.365'E) and S Kallang yellow mark (01° 16.820'N 103° 52.600'E)

Point B - a 1 Nm line due North South of Safe water mark (16° 56.890'N 54° 04.400'E)

Port of Spain, Trinidad - Store Bay, Tobago

The established distance is 129.6 Kilometres / 80.5 statute miles / 69.9 nautical miles.

Point A - Cap Sig North (WP6 10° 40.643'N 061° 35.272'W)

Point B - Pigeon Point North (WP25 11° 10.181'N 060° 51.012'W)

Round Anglesey

The established distance is 122.232 Kilometres / 75.951 statute miles / 66 nautical miles.

Point A/B - a Line between Beaumaris Pier and buoy B10.

Round Great Britain

The established distance is 2524 kilometres / 1568.3 statute miles / 1362.81 Nautical Miles.

Point A/B - a line to be determined by the applicant who will be responsible for making proper application to the National Authority from whose jurisdiction the attempt is started from.

Round Great Britain and Ireland

The established distance is 3308.84 Kilometres / 2056.46 statute miles / 1787 nautical miles

Point A/B - a line to be determined by the applicant who will be responsible for making the proper application to the National Authority from whose jurisdiction the attempt is started from.

Round Ireland

The established distance is 1303.8 Kilometres / 810.1 statute miles / 704 nautical miles.

Point A/B - a line to be determined by the applicant who will be responsible for making the proper application to the National Authority from whose jurisdiction the attempt is started from.

Round Ireland and Rockall

The established distance is 1902.9 Kilometres / 1182.4 statute miles / 1027.5 nautical miles.

Point A/B – a line to be determined by the applicant who will be responsible for making the proper application to the National Authority from whose jurisdiction the attempt is started from.

Round Isle of man

The established distance is 119 kilometres / 64.3 nautical miles / 74 statute miles.

Point A/B - a line to be determined by the applicant who will be responsible for making the proper application to the National Authority.

Round the Isle of Wight

The established distance is 88.5 Kilometres / 55 Statute miles / 47.8 Nautical miles.

Point A/B – a line from the Royal Yacht Squadron flagpole to the South Bramble buoy or another line pre-approved by the National Authority.

Round Isle of Wight - Channel Islands, Scillies - Isle of Wight (Southern Islands)

The established distance is 990.8 Kilometres / 615.7 Statute miles / 535 Nautical miles.

Point A/B - a line to be determined by the applicant who will be responsible for making proper application to the National Authority from whose jurisdiction the attempt is started from.

Round Italy – Memorial Fabio Buzzi

The established distance is 2111.3 Kilometres / 1311.9 Statute miles / 1140 Nautical miles.

The established distance is

Point A - Venice: Lido di Venezia in front of the Excelsior hotel.

Point B - Monte Carlo: a line due East of the Yacht Club de Monaco.

Round Malta

The established distance is **75.19** Kilometres / **46.69** Statute miles / **40.6** Nautical miles.

Point A/B - a line to be determined by the applicant who will be responsible for making the proper application to the Maltese National Authority from whose jurisdiction the attempt is started from.

Round Malta & Gozo

The established distance is 105.93 Kilometres / 65.82 Statute miles / 57.2 Nautical miles.

Point A/B - a line to be determined by the applicant who will be responsible for making the proper application to the Maltese National Authority from whose jurisdiction the attempt is started from.

Round New Zealand

The established distance is 3841.31 Kilometres / 2388.1 statute miles / 2073 nautical miles.

Point A/B - a line to be determined by the applicant who will be responsible for making the proper application to the National Authority.

Round Sicily

The established distance is 807.47 kilometres / 501.74 Statute miles / 436 Nautical Miles.

Point A/B - is a Point off of Messina at Coordinates 38° 11' 41 N" 15° 34' 44" E

Sabang, Indonesia - Galle, Sri Lanka

The established distance is 1666.8 Kilometres / 1035.7 Statute miles / 900 Nautical miles.

Point A - a 1 Nm line due North of (05° 53.630'N 95° 18.600'E)

Point B – a 1 Nm line North South of the Fairway buoy (06° 00.550'N 80° 13.260'E)

Salalah, Oman – Gibraltar (Including transiting the Suez Canal)

The established distance is 7259.84 Kilometres / 4511 Statute miles / 3920 Nautical miles.

Point A - a 1 Nm line due North South of Safe water mark (16° 56.850'N 54° 04.400'E)

Point B - a 1 Nm line due South of Europa Point Lighthouse, Gibraltar (36° 06.575'N 005°20.690'W)

Salalah, Oman - Aden, Yemen

The established distance is 1094.53 Kilometres / 680.11 Statute miles / 591 Nautical miles.

Point A - a 1 Nm line due North of Safe water mark (16° 56.850'N 54° 04.400'E)

Point B - a 1 Nm line due South of Aden No.1 buoy (12° 44.490'N 44° 56.830'E)

Salalah, Oman - southern entrance to the Suez canal

The established distance is 3526.2 Kilometres / 2191 Statute miles / 1904 Nautical miles.

Point A - a 1 Nm line due North of Safe water mark (16° 56.850'N 54° 04.400'E)

Point B - a line between the 161 km markers at (29° 55.880' N 32°33.825' E)

San Francisco, USA (Golden Gate Bridge) – Long Beach, USA (Queen Mary)

The established distance is 415 Statute Miles (360.6 Nautical Miles), (667.9 Kilometres)

Point A: Golden Gate Bridge – a line between 37°49'31.67" N - 122°28'45.06" W and 37°48'38.67" N - 122°28'39.02" W

Point B: Queen Mary – a line between 33°45'11.07" N - 118°11'18.13" W and 33° 45'23.47"N - 118°11'0.14"W

Singapore - Sabang, Indonesia

The established distance is 1148.24 Kilometres / 713.48 Statute miles / 620 Nautical miles.

Point A - The entrance to Marina Bay harbour A line between S Marina yellow mark (01° 16.700'N 103° 52.365'E) and S Kallang yellow mark (01° 16.820'N 103° 52.600'E)

Point B - a 1 Nm line due north of the warning signal mark on land (05° 53.630'N 95° 18.600'E)

Transatlantic - New York (USA) to the Lizard (UK):

The established distance is 5296.72 Kilometres / 3291.2 Statute miles / 2860 Nautical miles.

Point A - a line drawn due south (true) from the highest point of the Ambrose Light Tower (40 27.53N, 73 49.88W).

Point B - a line due south (true) from the highest point of Lizard Point Lighthouse (4957.58N, 05 15.07W). Pass within 1.5 nautical miles of each of these points.

Transit though the Panama Canal:

The established distance is 92.6 Kilometres / 57.5 Statute miles / 50 Nautical miles.

Point A - a 1 Nm line North South through the Safe Water mark at the Eastern entrance of the canal

Point B – a 1 Nm line North South through the Safe Water mark at the Western entrance of the canal Distance:

Transit through the Suez Canal

The established distance is 166.68 Kilometres / 103.6 Statute miles / 90 Nautical miles.

Point A - a line between the 161 km markers at (29° 55.880' N 32°33.825' E)

Point B – a line between the No 5 Buoys at (31°19.130' N 32°22.100' E)

Transpacific

The established distance is 15371.6 Kilometres / 9551.5 Statute miles / 8300 Nautical miles. (Approx.)

Point A - a 1 Nm line North South through the safe water mark off any West Coast of USA Port.

Point B - Singapore - The entrance to Marina Bay harbour – A line between S Marina yellow mark (01° 16.700' N 103° 52.365'E) and S Kallang yellow mark (01° 16.820' N 103° 52.600' E)

Trans-Tasman - Sydney to Auckland

The established distance is 2363.21 Kilometres / 1468.8 Statute miles / 1275 Nautical miles.

Point A - the Sydney Harbour Bridge.

Point B - the Auckland Harbour Bridge.

West Palm Beach - Cocoa Beach-Cape Canaveral

The established distance is 188.53 Kilometres / 117.14 Statute miles / 101.8 Nautical miles.

Rocket Run, Standard Lap Name Coordinates Bearing Distance Rounding

T1 26° 29'.359 N / 80° 01'.877 W 89.5° 1.13 Port

T2 26° 46'.369 N / 80° 00'.609 W 343.7° 24.64 Port

T3 27° 28'.638 N / 80° 15'.415 W 341.4° 19.64 Port

T4 26° 31'.951 N / 78° 33'.171 W 341.3° 56.39 Port

T5 28° 22'.055 N / 80° 35'.861 W Starboard

West Palm Beach, USA - Freeport, Bahamas

The established distance is 161.3 Kilometres / 100.2 Statute miles / 87 Nautical miles.

Point A - 26°46'24.81"N and 80° 1'52.87"W

Point B - 26°46'16.60"N 80° 1'54.72"W

Whitehaven, England - Round Isle of Man - Whitehaven.

The established distance is 207.4 Kilometres / 128.9 Statute miles / 112 Nautical miles.

Point A - Whitehaven Harbour (54° 33'N, 003° 35'W), Entrance Point A - West Pier [Green] Lighthouse (WGS84 54° 33.1671'N 003° 35.9205'W)

Point B - North Pier [Red] Lighthouse (WGS84 54° 33.1641'N 003° 35.7441'W)

616.11 - Fees

The skipper or organisation wishing to make an attempt on a record is responsible for the costs of observing and ratifying it.

These must be paid in three parts as follows:

- On submission of the record attempt application to the relevant National Authority.
- Expenses incurred under 616.12 must be paid in advance of any record attempt.
- If attempt is successful then the required ratification fee will be forwarded to the National Authority.

(Details of the UIM Ratification fee is available from the National Authority)

616.12 - EXPENSES

The person or organisation making the record attempt is responsible for the legitimate expenses and remuneration of the National Authority assigned officials. This must be paid before any record claim can be considered.

616.13 - RATIFICATION

Pending official confirmation by the UIM, neither the driver, builder nor any other shall publish or cause to be published, circulate or cause to be circulated, the results of the trial, until the delegate of the National Authority has given the actual results in writing, after checking the calculations in the presence of timekeepers.

Even when such authorisation has been received, results may only be published with the addition of the words "Subject to official ratification by the UIM" in as large and prominent type as that in which any part of the notification itself is printed.

Neglect to comply with the above regulations automatically entails the refusal to recognise the record. The National Authority has the right to penalise whoever is responsible.

A request for ratification must reach the relevant National Authority within 14 days of the attempt being completed.

The following documents are to be submitted to the UIM/relevant National Authority; the submission may be by fax if followed up by the original documents.

- A statement by the skipper giving details of the vessel, the crew and the course followed. This must include a declaration that these rules have been followed, signed by the skipper and at least one other member of the crew.
- A report by the Official Observer giving details of the timing and verifying the accuracy of all observations.

616.14 - INTERPRETATION

In case of any dispute over any of these rules, the decision of the relevant National Authority is final.

GROUP 700 CUPS AND TROPHIES

700.01 - INTERNATIONAL CUPS

The National Authorities must send to the Secretary of the UIM a copy of their international Cup Rules, Year Books, official Statutes and other publications. These documents will be held for reference by all National Authorities.

701 - PAVILLON D'OR

THE "PAVILLON D'OR" CRUISE

701.01 - ORIGINS

Following a proposal by the French Federation of Automobile Navigation, the International Union established, during its general assembly of 5, 6 and 7 October 1936, the International "Pavillon d'Or" cruise which takes place each year, according to the general rules of the UIM and to those of the following cruise, valid for both cruises.

701.02 – ADMINISTRATION

Yearly cruise

The "Pavillon d'Or" cruise is inscribed yearly in the International calendar.

Organising country

Each year, the organisation of the event is entrusted to one of National Authority affiliated to the UIM National Authorities wishing to organise this cruise shall make an application to the UIM.

The National Authority of the designed Country indicates to the UIM the body affiliated to its National Federation, the club to which the organisation of the "Pavillon d'Or" cruise will be entrusted, together with the name of the person in charge.

Rules

Bodies entrusted with the organisation of the "Pavillon d'Or" cruise undertake to abide both by the rules specific to the cruise and to the UIM rules relating to pleasure navigation.

Organisation costs

The cruise's organisation costs are borne by the organising body.

The said body may accept sponsors.

"Pavillon d'Or" Cups

The "Pavillon d'Or" shall be awarded to the yacht having left from the point furthest away from the final destination.

The yacht receiving the "Pavillon d'Or" may also be awarded cups or prizes according to the specific rules of the Cruise's programme.

The number of cups allotted on the occasion of the cruise is unlimited and each organising body may set the number as it sees fit. All cups and prizes remain the property of the winner.

Each participant in the "Pavillon d'Or" cruise receives a commemorative souvenir.

Prizes in cash

No cash prizes may be awarded on the occasion of the “Pavillon d’Or” cruise.

Failure to organise

If, for any reason recognised as being valid by the UIM, the National Authority designated to organise the cruise is unable to do so, the National Authority which received the second highest number of votes shall be entrusted with the said organisation, or the next best National Authority if the latter is unable to do so.

Dates

The cruise takes place each year between 1 June and 25 September.

The National Authority shall communicate to the UIM the date of the “Pavillon d’Or” cruise, at the latest by September 30 of the year preceding the cruise, to enable the event to be published in the calendar of the UIM

Program and specific rules

The program together with the specific rules, approved by the National Authority, shall be published at the latest 45 days before the event and communicated to the UIM

Qualification

The cruise is open to all inhabitable motor yachts. Auxiliary sails may be used. The owners shall belong to a National Authority.

No distinction is made between the various yacht categories. The number of engines and their power is not taken into consideration.

The “Pavillon d’Or” cruise is a regularity event. No sheer speed events may be organised.

The rules provide that the services of a pilot are acceptable for certain rivers. However, yachts shall navigate using their own means.

Registration fees

Registration fees set according to the advance program shall be sent to the organising club.

Registration fees shall reach the organising committee at the latest four weeks prior to the cruise’s official date of arrival.

In the event of default, the entry fee remains in the hands of the organising committee.

The registration fee set by the organising committee may not be modified.

Yachtsmen not members of a club affiliated to a National Authority may take part in the cruise as long as they abide by the conditions set by the said authority.

Registration fees are split as follows :

80 % to the organising club;

10 % to the National Authority;

10 % to the UIM;

In addition, the UIM receives the inscription for the calendar;

701.03 - THE CRUISE

Departure

No departure shall take place more than three months prior to the cruise's official date of arrival.

Point of departure

Competitors are free to start from where they chose but shall cover at least one hundred nautical miles to reach the port of arrival. Such a distance shall not necessarily be calculated as to the route followed but may be covered as a circuit or loop provided always that the course is always in the general direction of the port of destination.

Ports of call

The organising body designates the ports and cities where the competitors shall stop for stopover controls.

Only such ports and cities designated by the organisers shall be considered to be official ports of call.

In the first port of departure, an official delegate enters in the log book the date and time of departure.

Stopovers

Any competitor whose stopover exceeds two weeks shall be disqualified.

Destination

The organising club shall fix in the rules that yachts the final date and time of arrival at the port of destination.

Any delay beyond the prescribed time shall lead to time penalties as stated by the specific rules of the race.

Ports of destination are :

- maritime for those yachts coming by sea;
- fluvial for those yachts coming via Inland routes;
- lacustrine for those yachts in inland waters.

Arrival

The organising club shall include in the specific rules all instructions relating to common routes.

Ports of concentration and ports of arrival shall be defined using polar co-ordinates Global Positioning System (GPS).

Route

Competitors are free to choose their route from the port of departure to the port of concentration. They may stop over in all ports excepting official ports of calls.

Log book

All participants receive a log book where the official delegates accredited by the organising committee enter :

- The place, date and time of departure;
- The places, dates and times of arrival for each port of call;
- The chosen port of concentration;
- The date and time of arrival at the port of arrival;
- Incidents during the race (breakdown), lock gates, etc.) and stopovers at unofficial ports of call;
- Navigation details.

Repairs

En route repairs are authorised, but the resulting time of immobilisation is not deducted. All yachts must reach the port arrival of the rally on the date specified in the program.

701.04 - THE CONTEST

Prizes and cups

Aside from the “Pavillon d’Or” itself, other prizes and cups may be awarded :

- to the 2nd and 3rd competitors having travelled the greatest distance;
- to the best log book;
- for any performance which may be calculated or measured, or defined by the specific rules of the organising committee;

Distance travelled

One point per nautical mile travelled is allotted, from the port of departure to the port of arrival. The distance is calculated as the direct route from start to finish using marine charts and official maps of lakes, rivers and canals.

Only the mileage travelled with the owner on board is taken into consideration.

Should two yachts cover the same distance, the “Pavillon d’Or” is awarded to the yacht having travelled the distance in the shortest time.

Other contests

Other contests or events may be decided by the organisers as they see fit.

All contests shall be clearly announced in the advance program.

Publicity

Press releases may only be issued by the National Authority or its delegate.

Jury

An international jury shall be appointed.

Definition of the “Pavillon d’Or”

A “Pavillon d’Or” shall be awarded to each competitor according to the attached model.

A log book shall be given to each competitor carrying the ensign of the organising club or the National Authority.

In the event that the arrival zone or port or arrival are located in an area common to several Countries, the National Authority of the organising committee may request the collaboration of the other Country(ies).

701.05 - CLAIMS

All claims shall be lodged in writing and submitted at the latest 12 hours after arrival at the port of destination.

Each claim shall be accompanied by a deposit in the national currency, the amount of which shall be set according to the Advance Program.

This amount shall be reimbursed if the claim is considered to be justified.

Decisions taken by the jury may not be appealed.

701.06 - PAVILLON D'OR FOR HISTORICAL BOATS

The UIM Pavillon d'Or has existed for several years to encourage the development of events for Historical Boats, the UIM has created the same trophy for historical boats.

This Trophy will be contested annually over a minimum of three events; additional events may be added upon the request of the interested National Authorities up to a maximum of 6 events spread over a minimum of three different nations.

The rounds for the Pavillon d'Or Trophy must be inscribed on the UIM calendar, the organising clubs must be a member of a UIM affiliated National Authority, except derogation as provided under article 3.1.1. of the UIM By Laws.

A round of the UIM Pavillon d'Or must contain following sections :

- Regularity test (100 points);
- Manoeuvring competition (140 points);
- Compliance with UIM/ASDEC Specifications (210 points);

Each round will establish a classification based on the sum of the points (450 points max) obtained for the three sections.

Additional items might be organised but they will not be taken into account for the award of the Pavillon d'Or.

The participating boats should be older than 25 years and comply with all legal rules of the Country where they are registered.

According to their classification in each event, the competitors will score points according to the UIM scoring system (400, 300, 225, 169, 127, 95, 71, 53, 40, 30, 22, 17, 15, 13, 9, 7, 5, 4, 3, 2, 1).

The overall classification of the Pavillon d'Or shall be based on the total of the points scored in all events.

The general classification will be given in two sections :

- CLASSIFICATION OF THE CREW ; thus leaving any crew the possibility to crew several different boats in the course of any competition.
- This facility will be agreed by the UIM in respect of the type of boat and of its usual base (e.g. boats which are too large to be transported by sea towards another circuit and vice-versa)
- CLASSIFICATION OF THE BOATS ; in applying the system combination Crew/Boat which means that the relevant boat will need to be driven by the same crew.

The "boat" classification will be called the Pavillon d'Or - Constructors.

The "crew" classification will be called the Pavillon d'Or - Crew.

(= to be compared with the F1 Car racing classifications).

Each organiser must submit an advance-programme to the UIM - Historical Boats Section - 60 days before the event will take place.

702 - TROPHY MARIO AGUSTA

702.01

The Trophy Mario Agusta is an award for drivers who use their vessels as pleasure craft and navigation during their holidays and leisure time.

702.02

The Trophy may be awarded annually at an event figuring in the UIM International Pleasure Navigation Calendar.

702.03

The type of participating vessel is restricted to craft constructed for pleasure or touring, with either a single engine or several engines. All craft must be in conformity with the rules and regulations governing this type of navigation in their Country of origin.

702.04

The maximum overall length permitted is eight meters.

702.05

Three craft specifications are allowed :

Craft with cabin;

Craft without cabin;

Inflatables.

702.06

The first prize will be awarded to the driver, a member of a federated club, whose National Authority is itself affiliated to the UIM, who has covered the longest distance, measured in nautical miles, in one or multiple journeys, by sea, through rivers, deltas and / or canals, indifferently.

702.07

Only those nautical miles covered during effective navigation will be taken into account.

702.08

The logbook must be kept and duly updated with daily entries indicating miles covered, ports & towns visited. Official entry & departure documents will be required by the UIM : documents such as visas and those issued by customs, port authorities, police, municipalities, tourist offices and lock operators, etc. so that the UIM can verify accounts of voyages.

702.09

The required logbook is that based on a model established by the UIM and must be purchased from the competitor's National Authority, as of February 01 each year. The logbook must be returned to the National Authority before October 15 of the same year. The National Authority will then transfer the logbook to the UIM before November 30, of the same year.

702.10

Trailored boats may compete in the Trophy. However, the trailored part of each voyage will not count as nautical miles. The logbook will be kept only for those parts of the voyage effectively accomplished in the water. Both operations, that of launching & of recovery of a trailored craft must be duly noted and validated by an official agent.

702.11

During the entire duration of the voyage/s, the presence of paid crew aboard is strictly forbidden.

The presence of a pilot aboard is allowed if the master of the vessel considers it necessary for reasons of security. Similarly, estuary or port authorities may require the presence of a pilot aboard in certain circumstances, in which case the master of the vessel must conform to such instructions.

702.12

The Trophy Mario Agusta Jury is composed of members of the UIM Pleasure Navigation Commission and the Secretary General of the UIM

702.13

Decisions of the Jury are final and may not be appealed. The results of the Trophy competition are announced by the Pleasure Navigation Commission after satisfactory examinations of the Competitors' Logbooks.

702.14

The present Rules and Regulations may be subject to modification or revision each year.

702.15

By the fact of registering as competitors for the Trophy Mario Agusta, those competing agree to the terms that neither the UIM nor any National Authority may be held in any way responsible for any form or sort of damage of whatsoever nature, either involving persons or material, which might occur during voyages counting for the Trophy.

702.16

Medals will be awarded to the winners of the various categories during the UIM General Assembly of the year following the Trophy competition.

703 - TROPHY SANZ PINAL

703.01

The Trophy Sanz Pinal is presented by the Federacion Espanola Motonautica as an annuity event. It is awarded annually to a member of a club, affiliated to a UIM National Authority, who has covered the greatest number of miles during an individual long-distance cruise.

703.02

The National Authority procures for all its clubs all necessary forms and regulations and examines the results of those under its authority, selecting the best result and communicating it to the UIM before the date of December 31 each year.

703.03

The basis of the contest is the total distance covered during an uninterrupted cruise of a maximum duration of 60 days, undertaken during a single year, and in so far as the parameters of the cruise are acceptable to the National Authority.

The log book of the national winner must be communicated to the UIM by the National Authority.

No distinction is made between voyages in the open sea and those taking place on inland waters. To be considered a candidate for the Trophy Sanz Pinal, the competitor must have completed at least 300 nautical miles during the cruise in question.

703.04

A competitor's log book must contain the following :

- Arrival & departure hours and dates for all stopover ports comprising official notification from port authorities, lock-keepers, customs officials etc.
- The distance covered between the various stopover ports and all navigational details concerning the voyage.

If the National Authority considers that the log book has not been properly kept, a competitor may be disqualified.

703.05

Any stretch of water covered twice over shall be counted once only. Stretches of water covered while the owner of the craft is absent shall not count as part of the voyage miles. National Authority officials calculate distances according to direct passage routing for sea voyages and according to official inland charts concerning inland waters.

703.06

The calculation of points, certified by the National Authority, corresponds to one point per nautical mile, the total number of miles covered being equal to the total number of points.

703.07

National Authorities, presenting the Trophy Sanz Pinal to their affiliated clubs, may add supplementary rules to the present international rules should they judge it necessary. The supplementary rules may not contradict the international rules of the Trophy Sanz Pina.



RADIO CONTROLLED RULES

2024

GROUP 100 UIM ADMINISTRATION

- 101 UIM EVENT SANCTIONS AND THE SPORTS CALENDAR
- 102 OBSERVERS
- 103 RACES RECOGNIZED BY THE UIM
- 104 NON APPROVED RACES
- 105 TITLED INTERNATIONAL EVENTS
- 106 INTERNATIONAL RADIO CONTROLLED CHAMPIONSHIPS
- 107 RESERVE NUMBER
- 108 WORLD AND CONTINENTAL CHAMPIONSHIPS
- 109 CLASSIFICATION
- 110 REMOTE CONTROLLED ENDURANCE RACE
- 111 REMOTE CONTROLLED HEAT RACING SERIES
- 112 REMOTE CONTROLLED OFFSHORE RACING SERIES
- 120 INTERNATIONAL RACING LICENCES

GROUP 200 ORGANISATION OF RACES

- 200 ORGANISATION
- 201 RACE COMMITTEE
- 202 ADVANCE - PROGRAMME
- 203 ENTRIES
- 204 RACE PROGRAMME (RACING INSTRUCTIONS)
- 205 SAFETY
- 206 DISTINCTIVE MARKS

GROUP 300 RULES FOR CIRCUIT RACES

- 300 RULES FOR CIRCUIT RACES
- 301 TIMING
- 302 CIRCUIT
- 303 MARKS OF THE COURSE
- 304 RESERVE NUMBER
- 305 STARTING SIGNALS
- 306 STARTING PROCEDURE - ENDURANCE SERIES
- 307 STARTING PROCEDURE - RC HEAT RACING SERIES
- 308 STARTING PROCEDURE - RC OFFSHORE RACING SERIES
- 309 RACE CANCELLED
- 310 RACE POSTPONED

- 311 RACE STOPPED
- 312 RACING CONDUCTS – R.C ENDURANCE SERIES
- 313 RACING CONDUCTS – R.C HEAT RACING AND OFFHORE SERIES
- 318 CLASSIFICATION
- 319 DEAD HEAT
- 320 POSTING OF RESULTS
- 321 INSPECTION OF HULLS AND ENGINES
- 322 PRIZES
- 323 AFTER THE MEETING (REPORTS)

GROUP 400 JURISDICTION

Pleasure navigation section 400 is fully applicable

GROUP 500

- 500 SERIES AND CLASSES
- 502 INSPECTIONS
- 503 EXTRA BOATS
- 504 NOISE REDUCTION
- 505 REPLACEMENT OF MECHANICAL PARTS
- 510 CALLING TIME
- 512 HULLS
- 513 MACHINERY
- 520 BREAKING OF RULES
- 530 RETRIEVAL OF BOATS
- 540 LEAVING THE PONTOONS
- 550 FUEL
- 580 TURBO-JET AND ROCKET PROPELLED BOATS

GROUP 600 RECORDS AND PERFORMANCES

Pleasure Navigation Section 600 is applicable with the following recommendations :

See section 610 - Speed records

Art. 610.02 : the course is the “straight line” (100 meters)

See section 611 - Distance records

Art. 611.02 : the course is the “oval”

See section 612 - Hours records

Art. 612.02 : the course is the “oval”

Note : the “oval” course may be run either clockwise or counter clockwise. the option must be setted before the attempts and cannot be changed among the trials.

GROUP 700 ENVIRONMENTAL

- 701 NOISE LEVEL
- 702 EMISSIONS
- 703 RE-FUELLING
- 704 ENVIRONMENTAL CARE IN RACE AREAS

GROUP 800 OTHER COMPETITIONS

- 800.01 ELECTRIC POWERED BOATS
 - a CATEGORIES
 - b. ENGINES
 - c. BATTERY CELLS
 - D. HULLS
 - e. PROPELLERS
 - g. POWER DRIVE
 - G SPEED CONTROL
 - H ONBOARD ENGINE POWER BREAKER DEVICE J RACE NUMBERS
 - K CLASSES
 - L RACING COURSES
 - M NUMBER OF BOATS
 - N NUMBER OF HEATS
 - O STARTING PROCEDURES P END OF RACES
 - Q PENALTIES
 - R OTHER APPLICABLE RULES
- 801 SOLAR CELL
- 802 MARATHON RACE
 - 802.01 INDIVIDUAL RACE
 - 802.02 DRIVERS TEAM RELAY RACE
 - 802.03 DRIVERS TEAM RELAY RACE

GROUP 900 MISCELLANEOUS

- ENDURANCE COURSE
- HEAT RACING COURSE
- SPEED RECORDS
- ELECTRIC RECORD COURSE
- ELECTRIC OVAL COURSE
- 902 PLATES WITH RACING NUMBERS
- 903 ANNEX C (REF. RULES 312 / 313)

GROUP 100 UIM ADMINISTRATION

101 - UIM EVENT SANCTIONS AND THE SPORTS CALENDAR

101.01 - EVENT SANCTION REQUIREMENTS AND FEES

All international powerboating events must be sanctioned by the UIM and by the National Authority. An International Sanction is a written authorization which permits an organizing body to conduct an international event under the rules of the UIM

Written approval by the UIM of the registration of an international event on the UIM annual calendar, subject to payment of a fee determined annually by the General Assembly, constitutes the granting of an International UIM Sanction for that event.

Payment of these fees must be made within three months after the fixing of the international calendar. It is compulsory even if the meeting does not take place.

Permission to organise these meetings is only delivered by the UIM upon payment of these fees. No permission is to be granted to National Authorities in arrears of payment.

The registration fee is to be doubled for any meeting requested after the deadline dates set by the rules.

All requests to organise an international championship must be sent to the UIM Secretariat before the time set by the deadline in the rules.

When compiling the sports calendar due attention is to be paid to the confidential reports of the UIM observer before granting the request to organise titled meetings.

The organisers must make known the series and classes which may participate and also mention the name and address of the organisers and/or the responsible person(s) who is/are in a position to supply information about the event. They must also name the type of races : titled, championship, etc. the locality, the address of the race organisers as well as the date of the inscription. Such information must be provided as soon as possible.

101.02 - OTHER MEETINGS

It is forbidden to organise national championships for series and classes which are in the programme of a titles meeting taking place the same day. The Sports Calendar also lists the registered Ordinary International Meetings.

The calendar of national and local events is not to be submitted to the UIM The NA's concerned have responsibility for their own calendar.

The organisation of an event cannot be granted if the title, the locality and the date of said event are not given. UIM does its utmost to avoid clashes between national and friendly meetings.

However, whether the interested parties agree or disagree, the UIM lists all requests for dates, leaving it to the organisers to sort out their responsibilities.

The titled meetings have priority over all other meetings before the closing of the registrations for the sports calendar.

However, once the sports calendar has been finalised, all the remote-controlled motorboating meetings are on an equal footing.

A titled meeting which has been cancelled does not count any longer for the title. If the organisers decide to run the race in spite of the cancellation, the race must be considered as a friendly international race.

101.03 - DEADLINES

1 March :	Deadline for forwarding requests for entries
1 April :	Deadline for allotting international championships and races to the NA's 10
September :	Deadline for forwarding dates and venues by NA's
Calendar meeting	
October :	Deadline for drawing-up the calendar by the Working Group on Remote-Controlled Power boating (WGRCP)
15 November :	Publishing of the Calendar.

101.04 - CHANGE OF DATE

For any change of date of a World or Continental Championship requested after the 15th of December, UIM must give its assent to the new date proposed.

Any request for a change of date should be received by the UIM Secretariat at least 15 days before the date initially planned. The new date will be fixed at least 45 days after the date on which the change was announced.

The calendar fee will be doubled.

102 - UIM OBSERVER-DELEGATES AND COMMISSIONERS

102.01 - FUNCTIONS

The presence of a UIM Observer-Delegate or a UIM Commissioner is required for any international titled meeting, except in case of force majeure.

The function of Observer-Delegate or Commissioner must be fulfilled most cautiously.

Members of the Council, which includes all UIM Vice-Presidents, are entitled to be UIM Observer-Delegates or Commissioners.

102.02 - UIM OBSERVER-DELEGATE

He/she is not entitled to take part in any discussion.

He/she is not entitled to take sides as delegate of UIM, which he/she is not entitled to commit.

He/she is entitled to act as an adviser whenever his/her opinion is requested, but he/she is not entitled to act either as a referee or a mediator.

National Authorities are requested to send every year to the UIM Secretariat a list of candidates observers with the following data :

Name and surname

Full address

Telephone - Telex - Fax

Languages spoken

Languages read and understood

Is he/she free at all times ?

If not, when is he/she ?

Knowledge in powerboating

Knowledge in sports matters

Knowledge in technical matters.

As soon as he/she gets the Observer's agreement, the Secretary General of UIM will send a letter to the National Authority informing them that the Observer has been designated for the events referred to in the letter.

The Observer-Delegate is entitled to take action with the race organising committee if safety conditions are not met. In some cases, he/she will even be entitled to request that a Continental or a World Championship be suspended if safety conditions are not improved.

102.03 - UIM COMMISSIONER

The UIM Commissioner :

- assists the local organiser and more particularly the Officer of the Day
- is a voting member of the international jury
- approves last minute amendments to the advance-programme
- supervises the signing of drivers' declarations
- takes part in important decision-making during the race with the Officer of the Day, the Safety Office and the 2nd Commissioner, if any takes part in urgent decision-making with the Officer of the Day and the organising promoter, in matters related to the overall organisation.

The UIM Commissioner is entitled to take action with the race organising committee if safety conditions are not met. In some cases, he/she will even be entitled to request that the race be suspended if safety conditions are not improved.

102.04 - AFTER THE RACE

(applies to both the Observer-Delegate and the commissioner)

After the event, he/she sends his/her report to the UIM Secretariat by using the official form, within ten days after the race. The official results of the event must be enclosed with the report.

The reports from Observer-Delegates and Commissioners are to be considered as confidential matter and cannot be used for aims other than UIM's, not be communicated to the press or otherwise disclosed in any purpose whatsoever.

Should the Observer-Delegate or Commissioner fail to obtain all necessary data and results for transmission to UIM, he/she will note this fact in his/her report and will urge the organisers to send all required documents by themselves to the UIM Secretariat, as soon as possible.

A copy of the Observer-Delegate or the Commissioner's report will be sent as soon as possible to the President and the Secretary of the UIM Radio Controlled Sub-commission.

The National Authority must remind the organisers that the Observer-Delegate and the Commissioner must be accommodated in a good hotel for the whole duration of the event and as long as required by the fulfilment of their mission.

The costs of such accommodation are borne by the organisers.

102.05 - TRAVEL EXPENSES

The National Authority must also make it clear that travel expenses for the Observer-Delegate, from his/her town of residence to the place where the meetings are taking place, calculated on the basis of a return air ticket, are also borne by the organisers.

The expenses referred to above must be refunded to the Observer-Delegate during their stay by the organisers or to UIM upon receipt of the relevant invoice.

103 - RACES RECOGNISED BY THE UIM

The UIM recognises the following events :

- international titled events
- international ordinary events
- national and local events
- club meetings.

104 - NON-APPROVED RACES

All races not organised according to UIM rules are not to be recognized.

The same applies to motorboating events not approved by National Authorities.

A national race, or a race by "invitation" in which a foreign licensed driver is invited to take part must be entered on the UIM Calendar otherwise it becomes an unauthorised event, unless no more than 3 foreign drivers take part for the reason of training and without inclusion of their results/times in the results sheets. Remember that drivers having international licences, are only allowed to enter a meeting outside the country of their license, provided that their National Authority gives them written permission to do so.

105 - TITLED INTERNATIONAL EVENTS

The word "international" defines the type of race. It is impossible to know beforehand the number of countries which will participate.

There are three categories of titled meetings :

- World Championships
- Continental and Hemispheric Championships
- International and National Grand Prix.

No meeting is allowed a title unless authorised to do so by the UIM who draw-up the annual list in the official calendar.

The UIM has the right to refuse a title if it thinks that the amount of prizes or the quality of the organisation are not acceptable.

Whenever possible, titled events should recur the same period every year.

Since UIM aims at protecting titled meetings, its Radio Controlled Sub-commission may refuse to sanction any meeting which takes place at the same time. Such refusal is only notified at the specific request of the National Authority lodging a protest.

In order to promote new series and classes, new hulls, motors or engines, new ideas regarding propulsion and new concepts of racing, the Radio Controlled Sub-commission may, provided the request to organise be accompanied by an amount equal to double the fee of an ordinary meeting, approve the organisation of international contests for such boats, motors or engines, type of propulsion and races of a kind not yet known to the UIM, provided such events do not clash with other UIM titled meetings at the sole discretion of UIM Safety conditions have to be met.

106 - INTERNATIONAL R.C. CHAMPIONSHIPS

106.01 - GENERAL RULES

International Radio Controlled Championship are open to all UIM Classes and should take place under UIM rules.

The requests to organise these championships must be sent in due time. The Radio Controlled Sub-commission will allocate the Championships.

The UIM delivers, following requests made by the champions of the National Authorities and transmitted to that National Authority to the UIM Secretariat, a "Champion's Certificate".

The cost of such a certificate is fixed annually by the General Assembly and is to be paid by the National Authority to the UIM when the request is made.

A list of champions is issued annually.

The UIM rules and those of the National Authority are applicable to any point not foreseen in these rules.

A non-European citizen may be proclaimed European Champion provided he/she has had a European licence for more than two years. The same applies to all continents.

Immediately after the Championship, the name of the Champion must be transmitted by cable to the UIM Secretariat.

Permission to organise a championship is granted only if the race is run on a course recognised by the National Authority and homologated by UIM

All national authorities having homologated the courses where events are to take place send a list of them to the UIM Secretariat, with a plan to scale.

107 - RESERVE NUMBER

108 - WORLD AND CONTINENTAL CHAMPIONSHIPS

108.01 - NUMBER OF CONTINENTAL AND WORLD CHAMPIONSHIPS

There can be one World Championship and one Continental Championship per year, per class, as approved by the UIM Pleasure Navigation Commission.

A Championship event can only be organized in an International meeting. (e.g. National G.P.'s may be proposed by the requesting organizing country to become the World Championship for a given year).

The World Championship is to take place in only one dedicated Race.

The Continental Championship is to take place in a series of races; (e.g. National G.P.s may be proposed by the requesting organizing country to become part of the series that will give points for the Continental Championship of the given year).

Final classification will be given by the total point scored by each competitor in each raced Continental Championship.

108.02

A championship for any class can only be confirmed when a minimum of three competitor entries is met.

108.03

The right to organise Continental and World Championships is annually rotated in the alphabetical order of the French names of the affiliated countries.

If a nation declines to organise a championship the next in rotation is taken into consideration.

If a country applies for the organisation of a championship for a certain year but fails to organise it, this country is considered as having held the championship as far as rotation is concerned.

108.04

Each country may designate 1 to 15 drivers according to its own rules. The defending champion participates additionally.

Drivers must be able to show their international licence.

108.05

Entries are to be sent by the National Authority to the organising National Authority before the deadline fixed by the latter.

108.06

Any equipment used in racing must be in conformity with UIM rules.

108.07

After the race, the equipment of the three first classified drivers, hull and engine, are measured by the official measurer if required. The title of champion is only granted after satisfactory examination of the aforesaid equipment.

Repairs are permitted.

In those classes where engines are restricted, substitutions can only be effected with original parts. Cylinder dimensions are measured when the engine is cold.

Allowance is made for the carbon and oil present in the combustion chamber.

108.08

A championship can only be held in international meetings.

The races for Championships are not to be combined with races for cups or trophies bearing another name.

No person shall be proclaimed:

A "World Champion" or a "Continental Champion" unless at least three competitors from two different Nations have competed for the title.

108.09

The top three drivers of each class receive UIM gold, silver and bronze medals.

Other prizes may be awarded.

A driver who has entered for a World or Continental Championship cannot be compelled to enter other races programmed during the meeting.

108.10

As soon as the results have been verified, the National Authority forwards them to the UIM Secretariat.

109 - CLASSIFICATION

For events with two or several races :

109.01

The final classification is given by adding the results of each driver in each race.

109.02

All races registered in the calendar are taken into account.

109.03

For each race, the classification will be as follows : 1 = 400 pts

2 = 300 pts

3 = 225 pts

4 = 169 pts

5 =	127 pts
6 =	95 pts
7 =	71 pts
8 =	53 pts
9 =	40 pts
10 =	30 pts
11 =	22 pts
12 =	17 pts

Drivers classified thirteenth onwards will be granted 10 points.

In case of dead-heat, the driver classified in the highest number of races is the winner. In case of second dead-heat, the driver best classified in the last race is the winner.

110 - REMOTE CONTROLLED ENDURANCE RACE

110.01 - COURSE

The course provided for in Endurance racing is reproduced herein (see Fig. 1 - Art. 901.01).

The buoys must be cylinder- or cone-shaped, with their axis placed vertically and the following dimensions : diameter 300 mm minimum and 500 mm maximum, 400 mm minimum height above water.

Their colour must be highly visible.

110.02 - RACING CONDITIONS

Races consist in covering a many laps as possible within a determined time, in competition with other boats. They must rotate anti-clockwise.

Boats must always start from the starting pontoon.

The arrival line is located in front of the Jury.

110.03 - ACCESS TO FINAL HEAT

The selection of competitors to final heat is done through qualifying heats.

110.04- NUMBER OF QUALIFYING HEATS

Each competitor can take part in three qualifying heats whose duration has been provided for in rule 110.07. The best heat is taken into consideration for the access to the final and/or semi-final heats.

110.05 - DIRECT FINAL

When the number of competitors is 12 or lower than 12, qualifying heats do not take place.

The direct final will be run in two heats of 30 minutes each. The best result of each competitor will be considered for the final classification.

Should two competitors be transmitting on the same frequency, the first entry will come first.

110.06 - NUMBER OF COMPETITORS

The maximum number of competitors admissible for each heat is 12. The minimum number of entries is 3.

Should there be less than 30 competitors qualified at the end of qualifying heats, the first twelve qualified have a direct access to the final heat.

Should there be 30 competitors qualified or more, the first nine qualified will have a direct access to the final heat.

Competitors classified 10th to 21st have access to a semi-final, the first three classified will go to the final in the same ranking order from position 10 to 12.

The semi-final results count only for access to the final, the competitors that do not entered the final will maintain their original qualifying ranking as far as the general classification is concerned.

110.07 - DURATION OF HEATS, SEMI-FINALS AND FINALS

- Qualifying heats 10' (ten minutes) - dead boats remains on the course
- Semi-finales 10' (ten minutes) - dead boats remains on the course
- Finals 30' (thirty minutes) - dead boats are retrieved and may restart

110.08 - STARTING AND END-OF-RACE SIGNALS

The beginning and the end of each race are indicated by a sound signal.

110.09 - SUSPENSION OF THE FINAL

Finals must always take place within the period of time provided for in the rules governing the various series and classes. Should it be interrupted by the Jury, the final will be resumed and competitors will be given the positions they had just before the race was suspended.

The boats that were racing at the time the race was suspended have to come back immediately and must be controlled by the judge in charge of the starting procedure so that no action takes place that would involve an immediate disqualification.

110.10 - SUSPENSION OF A HEAT AND/OR A SEMI-FINAL

Should a qualifying heat and/or a semi-final be suspended, the latter can not be resumed but must be raced again.

110.11 - END OF RACE

For each competitor, the race ends after the end-of-race signal. The boat completes its last lap. This lap will be taken into account and the time required to complete the course will be deducted.

The competitor will however have to cover a lap at a reduced speed to come back to his/her own space on the pontoon in order to avoid disturbing other competitors still racing.

The boat crossing the arrival line more than twice after the end-of-race signal will be penalised by as many laps as the laps unnecessarily covered.

Competitors who were stopped when the end-of race signal was given are not allowed to resume the race and are penalised by two laps in case they do so.

110.12 - CLASSIFICATION

The classification is established on the basis of the number of laps completed by each boat, from the starting signal up to the end-of-race signal, penalties deducted if any.

110.13 - DEAD-HEATS

In case of dead-heats by the number of laps, the first boat completing the course within the shortest time will be classified first.

In case of a dead-heat, the results of the other qualifying heats will be taken into account to determinate admissibility to the final. Should there still be a dead-heat, the names would then be drawn by lots.

During the final, should there be several boats stopped with the same number of laps and should they fail to complete the lap in progress after the end-of-race signal, they will be classified in the order of their last pass in front of the timekeepers.

110.14 - CHANGING QUARTZ FOR THE FINAL

The competitor who covered the smallest number of laps in qualification has to change his/her quartz if required. Should he/she be unable to do so, he/she will not start and will be classified last in final.

110.15 - SERIES STARTING GRID DRAWN BY LOTS

The series starting grid is publicly drawn by lots 30' before beginning of the race.

The series starting grid and racing numbers are randomly allocated by the software governing the laps counter and the time keeping. They should be available at the time of entries check.

Positions of competitors on the starting pits may also be randomly changed from round to round within the same heat.

110.16 - RADIO TRANSMITTERS

Competitors will keep their radio transmitters during the whole competition. They will be responsible for them.

Any competitor caught while manipulating his/her transmitter on the ON position outside the qualifying heat or the final in which he/she is racing will be disqualified for the competition and for all the categories in which he/she is involved.

Moreover, he/she will be reported to UIM and his/her National Federation.

The radio transmitter frequencies must comply to local regulations and/or restrictions of the hosting country.

111 - REMOTE CONTROLLED HEAT RACING SERIES

111.01 - COURSE

The course provided for in Heat Racing series is reproduced herein 901.02 (Fig.2).

111.02 - BUOYS

The buoys must be cylinder or cone-shaped, with their axis placed vertically and the following dimensions: diameter 150 mm maximum, 300 mm minimum height above water.

They must be made of a material that does not damage hulls in case of a collision (i.e. expanded polystyrene) and must bear visible coloured stripes (red or orange).

111.03 - RACING CONDITIONS

Races consist in covering a pre-determined number of laps, in competition with other boats. They must rotate clockwise.

111.04 - NUMBER OF QUALIFYING HEATS

It is up to the organising committee to determine the number of qualifying heats. Each competitor must have at least 4 (four) qualifying heats to run.

111.05 - NUMBER OF COMPETITORS

The maximum number of competitors admissible for each heat is 8. The minimum number of competitors is three.

111.06 - DURATION OF HEATS AND OF THE FINAL

Qualifying heats, semi-finals and final: 6 (six) laps ALL CLASSES

111.07 - STARTING AND END OF RACE SIGNALS

The beginning and the end of each race are indicated by the clock.

111.08 - SUSPENSION OF THE HEAT

Should the heat be suspended, the whole racing procedure is restarted.

111.09 - END OF THE RACE

For each competitor, the race ends when 6 (six) laps are completed without penalties. When lap penalties occur, same number of extra laps must be run in order to gain a finished score.

After finished his/her race the competitor must slow down to come back to his/her position on the pontoon without disturbing other competitor still racing.

111.10 - CLASSIFICATION

The classification is established by adding the competitor's scores for each race, deducting penalties if any.

111.11 - GRANTING OF POINTS

For each race, points are granted to competitors as follows: 1 = 400 pts

2 =	300 pts
3 =	225 pts
4 =	169 pts
5 =	127 pts
6 =	95 pts
7 =	71 pts
8 =	53 pts
Not finished :	25 pts
Not started :	0 pts

Scores are given in the order of arrival of the race and are added to the scores of the previous races to make the final classification.

111.12 - QUALIFICATIONS

If at the end of qualifying heats there are less than 20 competitors qualified, the first 8 classified will be eligible for the final.

Should there be 20 competitors qualified or more, the first 4 would directly go to the final.

Competitors classified 5th to 20th form two semi-finals; the first one is composed of the odd positions (5, 7, 9...) and the second one is composed of the even positions (6, 8, 10...) that cover only one heat.

The first two classified in each semi-final will complete the final starting grid.

In case of dead-heat, the result of qualifying heats is taken into account. In case of second dead-heat, the name of the winner is drawn by lots.

111.13 - FINAL

8 competitors maximum take part in the final. These competitors start three heats minimum.

The final classification is provided by adding the points scored in each heat.

111.14 - DEAD HEAT

At the end of the final, should there be a dead-heat for the first place, and in that case only, an additional race will take place between these two competitors in order to determine the winner.

111.15 - RADIO TRANSMITTERS

Competitors will keep their radio transmitters during the whole competition. They will be responsible for them.

Any competitor caught while manipulating his/her transmitter on the ON position outside the qualifying heat or the final in which he/she is racing will be disqualified for the competition and for all the categories in which he is involved.

Moreover, he will be reported to UIM and his/her National Federation.

The radio transmitter frequencies must comply to local regulations and/or restrictions of the hosting country.

112 - REMOTE CONTROLLED OFFSHORE RACING SERIES

112.01 - COURSE

- A) The course provided for a Heat Racing series is reproduced herein 901.02 (fig.2).
- B) For OF-1, some alternative courses may also be used:
 - 1) Course reproduced herein art. 901.02 (fig.2) but with straight length of 60 meters.
 - 2) Any four buoys course arrangement (arrival buoy included) with a minimal total length of 180 meters.
- C) Starting race procedures to be illustrated at the drivers briefing.

112.02 - BUOYS

The buoys must be cylinder or cone-shaped, with their axis placed vertically and the following dimensions: diameter 150 mm maximum, height above the water 300 mm minimum.

They must be made of a material that does not damage hulls in case of a collision (i.e. expanded polystyrene) and must be visible colored stripes (red or orange).

112.03 - RACING CONDITIONS

Races consist in covering as many laps as possible within a determined time, in competition with other boats. They must rotate clockwise.

112.04 - NUMBER OF QUALIFYING HEATS

It is up to the organizing committee to determine the number of qualifying heats. Each competitor must have at least 4(four) qualifying heats to run.

112.05 - NUMBER OF COMPETITORS

The maximum number of competitors admissible for each heat is 8. The minimum number is 3.

112.06 - DURATION OF HEATS AND OF THE FINAL

Qualifying heats, semi-finals and finals: 8 (eight) minutes ALL OFFSHORE Classes except OF-1. Qualifying heats, semi-finals and finals: 6 (six) minutes for OF-1 class.

112.07 - STARTING RACE SIGNAL

The beginning of each heats is indicated by the clock.

Only for OF-1 class jetty start with red lights.

112.08 - SUSPENSION OF THE HEAT

Should the heat be suspended, the whole racing procedure is restarted.

112.09 - END OF THE RACE

After the end of race signal all boats on the course must complete the last lap and the additional race time is recorded for each competitor;

The competitors must run an extra lap at low speed to come back to their own position at the start pontoon;

The boat crossing the arrival line more than twice after the end-of-race signal will be penalized by as many laps as the ones unnecessary covered.

Competitor who was stopped when the end-of-race signal was given are not allowed to resume the race and are penalized by 2 (two) laps in case they do it.

112.10 - HEATS CLASSIFICATION

The classification for each heat is established on the basis of the number of laps completed by each boat, from the starting signal up the lap completed after the end-of- race signal, penalties deducted if any.

112.11 - HEATS CLASSIFICATION – RACE CLASSIFICATION

The final classification of the race is obtained by adding the number of laps scored in the best “n-1” heats out of the “n” raced; the final timing of the race is obtained by adding the heats timing of the above mentioned heats. When the race format includes a “FINAL RACE” then art.112.12 and 112.13 apply.

112.12 – QUALIFICATIONS

1) When in the Race program a FINAL race is scheduled, then the following applies:

Should be less than 20 competitors qualified at the end of qualifying heats, the first 8 qualified have direct access to the final.

Should there be 20 competitors qualified or more, the first 6 (six) qualified will have direct access to the final.

Competitors classified 7th to 14th have access to a semi-final, the first 2 (two) classified will go to the final in the same ranking order in position 7 and 8.

The semi-final results count only for access to the final, the competitors that do not entered the final will maintain their original qualifying ranking as far as the general classification is concerned.

112.13 - FINAL

8 (eight) competitors maximum take part in the final of 1(one) heat.

112.14 – DEAD HEAT

If at the end of the race there is a dead heat for the First place an additional heats will take place between these competitors in order to determine the winner.

112.15 - RADIO TRANSMITTERS

The radio transmitters frequencies must comply with local regulations and/or restrictions of the hosting Country.

Competitors will keep their radio transmitter s during the whole competition.

They will be fully responsible for them.

Any competitor caught while manipulating his/her transmitter on the ON position, outside the qualifying heat or final in which he/she is racing, will be disqualified for the competition and for all the category he/she is involved.

120 - INTERNATIONAL RACING LICENCES

120.01 - COMPULSORY LICENCE

No one can take part in a race, establish or improve on a record in international class boats without being in possession of a licence from his/her National Authority.

In order to obtain an international license or Superlicence, following disclaimer must be signed by the licence holder:

“The undersigned _____ licensed pilot (licence no. _____), participating to UIM sanctioned events, yields the media rights of any coverage by the promoter taken during the event, to the UIM for further use by press, radio or television. The right however remains the property of the undersigned.

In addition I herewith agree and acknowledge the following:

U.I.M. is the governing rule making body of U.I.M. racing events which are responsibly organized by clubs, national authorities of UIM, contracted promoters or other organizers. These organizers do not act on behalf of the UIM and UIM is not responsible for any act or omission of such organizer and shall not be liable to the participant accordingly.

The U.I.M. sport and technical rules are intended to minimize risks but they cannot provide the highest possible safety standards at all times. Residual risks might remain.

Enforcement of the rules by UIM or other race officials and in particular but not limited to the technical scrutineering does not guarantee the safety of racing or the safety of the scrutineered boat. Scrutineering is not intended as a construction/ condition survey. The racing license issued by the National Authority or a super license issued by the UIM does not guarantee that a driver is physically able to race safely nor that he/she has sufficient experience or education.

Teams and drivers are solely responsible for their own safety including but not limited to their physical and educational ability to race in the relevant class, the safety of their boats and other gear and the safety of their racing activity. This responsibility includes racing with prudence and taking technical measures which are not mandatory in the rules but deemed necessary.

UIM shall not be liable for any damage, injury or death due to inadequate rules, breach of existing rules by participants or failure to enforce rules by the race officials.”

120.02 - REGISTRATION

The National Authority establishes every year a list of people to whom licences have been delivered and this is sent to the UIM Secretariat.

The list must include : the name and surname, the address and the licence number. These lists are sent to the National Authorities upon request.

Registration numbers are given by the NA and are “national” or “international” according to the criteria it has fixed.

Any National Authority has the right to deliver licences to:

- its nationals
- nationals of another country affiliated to the UIM but with the agreement of the National Authority of that nation

With the approval of UIM, a National Authority may also deliver licences to persons belonging to a country which is not yet affiliated to the Union.

Drivers are only permitted to hold licences from one National Authority.

A National Authority may refuse to give a licence without having to state the reason. Notification to this is sent to all affiliated clubs and to the UIM

120.03 - VALIDITY OF LICENCES

Licences are valid from the 1st of January until the 31st of December each year unless local circumstances require other dates, but validity should always be shown on the licence itself and must be for one year.

A licence is valid in any country affiliated to the Union and entitles the holder to enter or drive in all competitions organised in any affiliated country, provided he/she complies with what is stated in the UIM general racing rules.

However, for any event held under special rules, the licence holder must abide by the rules in question.

120.04 - COST OF LICENCE

The cost of the yearly licence is to be fixed by the National Authority.

120.05 - EXAMINATION OF LICENCES

At any meeting, the holder must produce his/her licence at the request of any official of the meeting.

120.06 - CANCELLATION OF LICENCE

Anybody who takes part in an unauthorised meeting loses his/her licence.

However, if the unauthorised meeting is held in waters of a country other than the one which has delivered the licence, both National Authorities must agree as to the duration of the suspension.

The UIM decides finally in case of a dispute.

120.07 - WILD CARDS

The National Authority who organizes a World or Continental Championship may issue a WILD CARD to each driver invited by aforesaid National Authority to attend its Event.

All the drivers who run with WILD CARD could receive all the prizes foreseen in that event.

If the winner of such Championship is a holder of WILD CARD, the title will be granted to the National

Authority who issued his/her WILD CARD.

The WILD CARD is free of charge and will be valid ONLY for the race in which it has been issued.

After the administrative control, the organizing National Authority will have to send to the UIM Secretariat a list of the issued WILD CARD before the start of the first race.

GROUP 200 ORGANISATION OF RACES

200 – RACE ORGANISATION

200.01 - GENERAL

The following bodies have the right to organise any R.C. motorboating event : National Authorities, Affiliated Clubs, Corresponding Members.

Affiliation to the National Authority implies their acceptance of the national rules and those of the UIM

A Club, member or driver who is suspended is not allowed to take part in any sporting event in his/her country or in any other country, neither as a driver nor as an official, as long as the suspension lasts.

A member or a driver who takes part in any race in a foreign country affiliated to the UIM undertakes ipso facto to abide by the rules of the National Authority of that country.

A member if a driver belonging to a country which is not affiliated is to be considered as a national of the country where he/she takes part in the race.

All Clubs, race organisers, officials and drivers are obliged to be acquainted with the general rules of the UIM as well as the rules related to races or series (local, national or international).

Two updated copies of the present rulebook must be available for every organisation.

All races organised by the National Authorities or their clubs are subject to the UIM racing rules. All rules and programmes must mention this.

The general racing rules and the rules related to records are applicable to all international series.

200.02 - INTERPRETATION OF THE RULES

In all cases not foreseen by the International rules or seemingly inaccurately defined, the National Authority, a race committee, race jury or an appeal board, is to judge bearing in mind the intention of the disputed rules.

Series and Class rules are a complement to general rules and are therefore to prevail.

The English text is the official one. In case of disagreement on the interpretation of these rules, the English text prevails.

201 - RACE COMMITTEE

201.01 - ORGANISING AUTHORITIES

All races are under control of the organising club who is to nominate :

- An organising Committee which organises the general and administrative aspects of the meeting.
- A Race Committee which organises and supervises the actual racing and decides whether competitors are eligible or not.
- The Race Committee has to deal with : safety, the race secretariat, buoys, technical problems, the starter and the recovery.
- A Jury in charge of setting all problems related to the rules.

The jury decides on any dispute submitted to them by the Race Committee, the names of the members are to be printed in the official programme.

The decisions made by the Race Committee and the Jury must be based on UIM rules. The Jury has to see to it that meetings are held in conformity with them and with the spirit of the sport.

The Organising Committee appoints a Committee that verifies all the licences and all other documents required. It also verifies whether boats, engines and radio equipment's are in conformity with the rules.

No officer nor member of the Jury nor member of a national or international Committee or Commission is allowed to intervene in the judgement of a problem in which he/she is involved himself or is an interested party.

The following are the Race Officials :

- the members of the Race Committee
- the Officer of the Day
- the Safety Officer (deputy to the Officer of the Day)
- the Secretary of the Race Committee
- the Technical Officers of the Race Committee
- the Course and Buoy Officers
- the Timekeepers
- the Lap Scores
- the Members of the Jury
- those in charge of retrieving boats
- the radio and sound level meter controller.

201.02 - THE OFFICER OF THE DAY

The Officer of the Day must supervise the organisation of races for which he/she is responsible to the organising clubs.

He/she must maintain order on the course, ascertain that all services are working properly, see to it that boats are in conformity with the racing rules and that the race is proceeding in accordance with the official programme ; he/she has to bring together the Officers' and Timekeepers' reports as well as all the information required to enable the results to be compiled.

201.03 - THE SAFETY OFFICER

He/she is deputy Officer of the Day. He/she is in charge of managing and/or co-ordinating (with the agreement of the Officer of the Day) all safety services on shore (medical care and fire) as well as on the water (boats and people on board the latter, equipment's). Whenever necessary, he/she stands for the Officer of the Day.

201.04 - THE RACE SECRETARY

The Race Secretary reports to the Officer of the Day and is responsible for the physical organisation of the meeting.

He/she has to make sure that the various officials are aware of their respective duties and are equipped with the accessories required. He/she has to collect all the documents of the meeting.

201.05 - DUTIES OF RACE OFFICIALS

Race Official's duties are limited to the tasks they have been entrusted with.

201.06 - TECHNICAL OFFICIALS

They have to check that the hull, the engine and the radio are in conformity with the rules. They check the good functioning of throttle and rudder controls.

They check the synchronisation of the clock and the camera (heat racing). After the race, they do all necessary checks.

201.07 - THE BUOY AND COURSE OFFICIALS

They must ensure that the drivers conform to the racing and course rules. At the end of the meeting, they draft and sign a report certifying that the drivers' conduct during the race and at the turn buoys was according to the rules.

The report is delivered to the Officer of the Day who takes all necessary measures regarding the application of rules.

201.08 - THE TIMEKEEPERS AND STARTER

Timekeepers will :

- calculate on completion the elapsed time for each driver - establish the finishing order after having made all necessary calculations
- hand their reports, with all documents required, to the Officer of the Day
- for international races, there must be at least two timekeepers. Their times and results must only be handed to the Officer of the Day. The Starter signals the start when ordered by the Officer of the Day.

201.09 - THE UIM OFFICIALS

The UIM Official :

- assists the local organiser, the Officer of the Day more particularly
- is a voting member of the international jury
- approves last minute modifications300 to the advance-programme
- supervises the signing of declarations by drivers
- takes part in important decision-making during the race with the Officer of the Day, the Safety Officer and the 2nd official if any- assists the Safety Officer in the organisation of rescue operations (more particularly in case the rescue team is external to the organisation)
- with the Officer of the Day and the race promoter, takes part in urgent decision-making regarding the general organisation.

202 - ADVANCE PROGRAMME

202.01 - FORWARDING DATE

45 days before any international race, the organising committee must forward at least one advance-programme to the UIM Secretariat, to the National Authorities and to the invited clubs and drivers.

Should rule 202.01 not be complied with, the Council has the right to request the Sports Commission to apply suitable penalty against international events during the following year.

Advance-programme arriving after the event at the UIM Secretariat are considered as not delivered. In this case, the fines laid down may be implemented.

202.02 - REQUIRED DETAILS

The above advance-programme must be written in the language of the organising country and in French and English and must contain the following information :

- 202.20 The name of the organiser
- 202.21 The series and the classes of boats catered for
- 202.22 The race or races which will be run
- 202.23 The venue and the date of the race (s)
- 202.24 The course of each race and plan drawn to scale
- 202.25 The sentence "the races are held under UIM rules"
- 202.26 The special conditions which in accordance with the UIM rules may be added
- 202.27 The time limit and place to which entries must be sent and whether written by telegram or by hand
- 202.28 The amount of the entrance fee
- 202.29 All information regarding the prizes for each race
- 202.30 Where and when the entry forms, programmes and racing instructions can be obtained from the organising committee
- 202.31 Transports facilities and concessions
- 202.32 Terms and conditions of a mandatory insurance for personal and material damage to third parties, competitors included
- 202.33 Minimum age of competitors required by law
- 202.34 Times for practice per class
- 202.35 Full instructions regarding noise regulations
- 202.36 Date provided, for the verification of the hull and the engine
- 202.37 Should no advertising be allowed during a race, this is to be mentioned in the advance-programme
- 202.38 The time limits for the late starters and finishers.
- 202.39 No modifications are to be made to any particular rule after the advance-programme is posted, except if decided by the Race Committee and approved by the Jury and for cases of force majeure only. The modifications must be communicated in writing to the officials and participants 1 hour before the first start at the latest.
- 202.40 Place and time of the drivers meeting.
- 202.41 Radio control equipment frequencies allowed and any other local regulations and restrictions

203 - ENTRIES

203.01 - RATIFICATION

The National Authorities must ratify in writing any entry for drivers wishing to race abroad.

Direct correspondence between the organising committee and foreign drivers is permitted but no entry is to be accepted unless approved by the driver's National Authority.

For Continental Championships the correspondence is held between the National Authorities. The Organising Committee will keep blank entry forms at the disposal of drivers.

An entry is not valid unless it reaches the organising committee within the time prescribed in the advance-programme.

203.02 - Admission

The Organising Committee has the right to decide whether the entrant is acceptable

No National Authority organising an international race has the right to refuse the entry of a foreign driver commissioned by his/her own National Authority provided said driver conforms to UIM rules.

The closing date for inscriptions may be a fortnight before the event.

203.03 ENTRY FEE

Each organising committee fixes the amount of entry fee for the races. Entry is valid only after payment of the entry fee.

The National Authorities have the right to establish a rule whereby higher fees are imposed on late entries.

203.04 - MINIMUM AGE AND IDENTITY

Each National Authority has the right to fix a minimum age for the drivers allowed to race on its water. Such age restriction is to be shown in the advance-programme.

The driver may only race under his/her name or pseudonym written on the licence.

203.05 - PUBLICITY ON THE BOATS

Advertisements may be freely applied on the entire surface of the boat.

The driver or mechanic cannot be compelled to carry any advertising whatsoever on their person, clothes or upon the boat that is being raced and his/their refusal to do so cannot in any way be an obstacle to their participation in any race.

Penalties may be applied to any driver who, in the course of any sporting event, has made any statement contrary to the truth or distorting facts.

Political publicity or immoral advertisements are not allowed.

Should no publicity be admitted for an event, this has to be announced in the advance-programme.

Any National Authority has the right to fix its own rules regarding publicity for its own boats and courses.

204 - RACE PROGRAMME (RACING INSTRUCTIONS)

204.01

The Organising Committee must clearly state the following points in their race programme (the official programme intended for officials and participants, not the programme to be circulated among spectators) :

- 204.11 Dates and Venues of races
- 204.12 Layout of course drawn to scale
 - Length of the course
 - Direction of the course
 - Starting line and its marks
 - Finishing line and its marks
 - Full details of buoys
 - Full details of fixed obstacles.

- 204.13 Starting time of each race
Signals for each race
Signals of postponement, cancellation, re-start and shortening of the race
- 204.14 Time when the control closes for each race
- 204.15 Full particulars of prizes for each race
- 204.16 Time limit and place for handing over the protests
- 204.17 Time and place of the distribution of prizes
- 204.18 Appeal procedure
- 204.19 Composition of the Race Committee, the Jury and the Technical Commission
- 204.20 List of the boats entered for each race and if possible, names and clubs of drivers
- 204.21 Place and time at which written instructions will be issued. Where and when the official time is to be communicated and place and time of drivers' meeting
- 204.22 Only drivers whose entries have been accepted by the organising committee have their names printed in the programme.

205 - SAFETY

205.01 - PROTECTIONS

Adequate protection measures must be taken in order to avoid that a boat getting out of the water generate casualties or damage.

For the same safety reasons, it is recommended that boats be controlled from a point located at 1 meter minimum above water level.

The jury will have to determine whether safety conditions are fulfilled.

205.02 - RETRIEVING BOAT

The Organising Committee has to provide for a boat that will retrieve the boats stopped on the course.

One motorboat having all characteristics to guarantee the safety of people in charge of retrieving boats will be used in this purpose.

A spare boat with similar characteristics will be immediately available if required. The retrieving boat will be equipped with an equipment composed of a pole of an adequate length at the end of which a linen strip or cloth or any such device has been attached, up to about 150 cm.

This equipment is meant to hold the boats when the latter have run out of control after a breakdown.

205.03 - PEOPLE IN CHARGE OF RETRIEVING BOATS

People in charge of retrieving boats have to wear a life jacket when performing their duties.

These people are not to be selected among competitors, mechanics of people directly or indirectly concerned by the same competition.

The retrieving order is the order in which boats have stopped, whenever possible. In all cases, it is up to the Officer of the Day.

205.04 - INSURANCE

All drivers must be covered by an adequate insurance, either through an insurance policy subscribed by him and shown before the start or through an insurance policy subscribed by the National Authority.

Do not underestimate your responsibility in case of accidents during authorised official practice before the boats and the documents required are checked. Only this verification is the evidence that the driver is properly insured.

205.05 - TECHNICAL PROTECTION

An engine is not allowed to be on while the propeller is in the air, except when putting the boat immediately on the water.

205 - DISTINCTIVE MARKS

206.01

The national flag is painted on a 5 x 3 cm rectangle on the deck, the bonnet or on the vertical part of the planking. This flag must be visible on one side of the hull.

The boat must also bear on the same side as the national flag, the boat registration number with the country's identification lettering.

206.02 - RACE NUMBER

The race number is determined by the Organising Committee. It may therefore vary at each competition.

Competitors have to equip their boats with their own plates, in conformity with the data provided in Fig. 5 (Art. 902) and bear the number provided by the Organisation.

206.03

In case of loss or damage to the identification plate, the competitor has to withdraw the boat immediately from the course.

The boat is not allowed to resume the race if the identification plate is not replaced or restored to be legible. The laps covered without a legible identification plate could be not scored when manual laps count is used.

206.04 UIM STICKERS

The UIM actual logo, minimum 6 cm in length stickers, supplied by the UIM or other manufacturer, must be attached to at least one side of all boats participating in UIM titled events.

The loss of the UIM logo will not be a reason for disqualification at post race technical inspections.

GROUP 300

RULES FOR CIRCUIT RACES

300 - RULES FOR CIRCUIT RACES

300.01 - DEFINITIONS

French	English	Italian	German
Course	Race	Gara	Rennen
Manche	Heat	Prove	Lauf
Tour	Lap	Giro	Runde
Circuit	Circuit	Circuito	Strecke
Parcours	Course	Percorso	Rennstrecke
Base	Base	Base	Messtrecke

CIRCUIT

A circuit is a closed course defined by buoys where races are to be held.

BASE

A base is a course expressly measured for record attempts.

COURSE

Total distance to be covered per heat or race.

MARKS OF THE COURSE

Any objects specially indicated as such in the race instructions are to be considered as marks of the course.

OBSTACLE

Any non specified object is considered as being an obstacle to free navigation.

RACE

A race is a competition in speed between boats held in one or more heats.

301 - TIMING

In all international races and national championships, the MYLAPS - rc4 automatic timing must be used in order to ensure accurate and reliable laps counting and time keeping.

All the boats must be equipped with "rc43" personal transponders.

Each competitor is responsible for the proper installation of his/her own personal transponders and its satisfactory operation.

The race managing software must be able to handle all the data requested by the racing rules and assuring on line display of the ongoing race as well as recording and print out of the race data.

301.01 - MANUAL LAPS COUNTING

Manual laps counting is only allowed as emergency back-up when authorized by the OOD.

302 - CIRCUIT

302.01

All circuits must be measured on the spot by the Officer of the Day.

302.02 - RACE CONTROL

Race control :

- a) should be situated so that the circuit can easily be controlled
- b) - the Officer of the Day or his/her assistant
- one or two officials or one or two members of the Jury.
- c) the officer of the day is the general observer of the race. He/she must be in contact with his/her assistant and the Safety Officer
- d) the other two supervisors share the circuit in observation.

303 - MARKS OF THE COURSE

303.01 - DEFINITIONS

The Marks of the Course are any objects (boat, buoy...) that are specifically designated as such in the racing instructions. The objects that are not designated specifically as such are to be considered as obstacles.

A buoy officer is posted near the turning marks. He/she must observe the turning of the marks and report to the Race Committee.

Should any mark be removed from its proper position, the Officer of the Day shall have it replaced.

Should it be impossible to replace the mark in time for boats to round it, the Officer of the Day shall decide whether the race is to be restarted or not (see art. 311).

Protection buoys may be placed on the circuit.

305 - THE START

305.01

Starts are :

- flying starts with clock or digital display
- dead engine starts

The clock must have a dial of no less than 1 meter.

In case of digital display, the height of each digit must be no less than 20 cm.

The clock is driven mechanically or electrically. It may indicate the seconds but should preferably be moving continuously.

The official start is given by the clock. In case of digital display, time elapses second after second.

305.02 - PLACE OF THE CLOCK

The axis of the clock or the digital display panel must be located on the starting line, no less than 1 meter above water level.

306 - STARTING PROCEDURE - ENDURANCE SERIES

306.01 - CALL TO THE PIT

After the call by the Race Officer, the competitor has two minutes to come to the pontoon ; after this time, the latter will be considered as failing to start.

306.02 - RADIO TESTS

After these two minutes, the Start Officer carries-out a radio test ; competitors whose radio is transmitting on a frequency different from the frequency stated will be disqualified from the heat or the final in progress. Should the equipment be faulty, they will be allowed to start only after they have repaired their radio and only after being authorised to do so by the Start Officer while the race is proceeding normally.

306.03 - RADIO INTERFERENCE

Should there be radio interference between competitors, the Start Officer is allowed to modify the position of competitors on the pontoon. Should the problem persist, the Start Officer will draw by lots the competitor who will replace his/her quartz.

306.04 - ENGINE WARMING-UP

At the end of the radio test, the competitor has two minutes to warm-up the engine.

The hull can be placed on the water, provided it is still held. Should the competitor fail to do so, he/she would be disqualified.

After that time, signalled by the Start Officer, each competitor and mechanic go to the space he/she has been assigned behind the boat and stay there until the starting signal, without touching anything on the hull or on its stand.

306.05 - SPACES ON THE STARTING GRID

Spaces on the starting grid must be marked-off and numbered 12 to 1 (see drawing on fig 1). Number 1 must be closest to the first turning buoy.

They must be between 1.50 and 2 m wide and deep.

In the first series of eliminating heats, the space occupied by the competitor is determined by the Jury ; in the second series, spaces are reversed, with the same race numbers.

The space and race number for finals is based upon the classification established after the eliminating heats. Space 1 is granted to the competitor who covered the highest number of laps in qualifying heats, and so on. In case of a direct final, race and space numbers are allocated by the Jury.

306.06 - STARTING SIGNALS

The Start Officer does the countdown as follows: 30" - 15" - 10" - 5 " and starting signal.

After that signal only, competitors are allowed to come closer to the boat and touch it.

Should a competitor or a mechanic touch the hull or anything connected to it before the starting signal are penalised by one lap.

306.07 - EARLY START

In case of early start of the engine, the competitor is disqualified for the heat in progress.

306.08 - PENALTIES

Calls to order and penalties incurred by competitors during a competition are notified by the Jury to the competitor or his/her mechanic on a yellow card to indicate a blame or a red card for a disqualification.

306.09 - POSITION IN THE RACE

Whenever possible during the heats and the final, the Jury should provide "non official" information on positions in the classification.

307 - STARTING PROCEDURE - RC HEAT RACING SERIES

307.01 - CALL TO THE PIT

After the call by the Race Officer, the competitor has two minutes to come to the pontoon ; after this time, the latter will be considered as failing to start.

307.02 - RADIO TEST

After these two minutes, the Start Officer carries-out a radio test ; competitors whose radio is transmitting on a frequency different from the frequency stated will be disqualified from the heat or the final in progress.

307.03 - RADIO INTERFERENCE

Should there be radio interference between two competitors, the Start Officer is allowed to modify the position of competitors on the pontoon. Should the problem persist, the Start Officer will draw by lots the competitor who will replace his/her quartz.

307.04 - SPACES ON THE STARTING GRID

Spaces on the starting grid must be numbered 1 to 8 (see drawing on Fig.2), n°1 being closest to the first turning buoy.

307.05 - STARTING PROCEDURE

Each heat in Heat Racing is composed of three different stages in the starting procedure :

307.05.01 - STAGE 1

Stage 1 is so-called "Pit time" or preparation time. It lasts two minutes during which the competitor starts the engine and launches the boat. The Start Officer authorises the launching of the boats.

Failure to wait the authorisation by the Start Officer would lead to a disqualification from the heat in progress.

At the beginning of this stage the starting clock, located at the centre of the circuit, in line with the arrival line, is started and a whole round of it takes 30".

Four red lights are simultaneously on, each of them being off every 30".

Should a competitor fail to start the engine and launch the boats during Stage 1, he/she will be considered not Started.

Should a competitor fail to start the engine during Stage 1, the heat would be considered null and could not be

repeated.

Competitors keep running on the racing course until the end of Stage 2. In case of digital clock, time is displayed backwards.

307.05.02 - STAGE 2

Stage 2 is so-called "Clock time". Its duration is 30" and it starts at the end of Stage 1. An orange light is on during the whole stage.

No boat can be put on the water during Stage 2.

During Stage 2, drivers have to drive their boats clockwise on the circuit in order to get to the starting line at the end of this Stage, which coincides with the beginning of Stage 3.

The end of Stage 2 coincides with the effective beginning of the heat, whatever the position of competitors on the course. It is signalled by a flash located on the clock and by the arm on the zero.

The heat is considered as effectively started when boats cross the starting line after the end of Stage 2.

Boats crossing the starting line before the end of Stage 2 are considered as having taken an early start and must therefore complete the lap and cross again the starting line.

307.05.03 - STAGE 3

Stage 3 is so-called "Course Time".

This stage consists in covering the number of laps required. The boat completing them first is the winner. Course is considered as completed only after laps penalties, if any, have been cleared.

307.06 - PENALTIES

A driver infringing the rules is inflicted a penalty lap or disqualification for the heat in progress if he/she damages another competitor. The infringement and the penalties inflicted must be immediately notified by the Start Officer to the competitor.

A boat that rounds a buoy inside at any moment of the three stages incurs a 1 lap penalty for each buoy so fouled.

A fouled buoy cannot be re-rounded.

Touching one or several buoys involves no penalty.

Should an infringement be of a serious nature likely to damage competitors' hulls, hurt spectators, etc. because of a wilful violation of rules, the offender would be excluded from the competition in progress as well as from all the other races that are to take place during the same event : this is subjected to a final judgement by the jury.

307.07 - COLLIDING WITH HULLS STOPPED ON THE COURSE

Colliding with a hull stopped on the course involves disqualification for the heat in progress.

Should a driver collide with a hull stopped on the course twice on the same event, he/she would be disqualified for the competition in progress as well as for all the other races that are taking place during the same event.

308 - STARTING PROCEDURE – RC OFFSHORE RACING SERIES

308.01 - CALL TO THE PIT

After the call by the Race Officer, the competitor has two minutes to come the pontoon; after this time, the latter will be considered as failing the start.

308.02 – RADIO TEST

After these two minutes, the Start Officer carries –out a radio test; competitors whose radio is transmitting on a frequency different from the frequency stated will be disqualified from the heat or the final in progress.

308.03 - RADIO INTERFERENCE

Should there be radio interference between two competitors, the Start Officer is allowed to modify the position of competitors on the pontoon. Should the problem persist, the Start Officer will draw by lots the competitor who will replace his/her quartz.

308.04 - SPACES ON THE STARTING GRID

Spaces on the starting grid must be numbered 1 to 8 (see drawing on Fig.2), n° 1 being closest to the first turning buoy.

308.05 - STARTING PROCEDURE

Each heat in Offshore Racing is composed of the following three stages. For OF-1 starting procedure see also 308.05.04.

308.5.1- STAGE 1

Stage 1 is so-called “Pit Time” or preparation time. It lasts two minutes during which the competitor starts the engine and launches the boat. The Start Officer authorize the launching of the boats.

Failure to wait the authorization by the Start Officer would lead to a disqualification from the heat in progress.

At the beginning of this stage the starting clock, located at the center of the circuit, in line with the arrival line, is started and a whole round of its takes 30”.

Four red lights are simultaneous on, each of them being off every 30”. Competitors keep running on the racing course until the end of Stage 2. In case of digital clock, time is displayed backwards.

Should a competitor fail to start the engine and launch the boats during step one, he/she has to wait until Stage 3 starts before launching his/her boat giving right of way to the other competitors already in the water. One lap penalty is given to all late starters.

308.5.2- STAGE 2

Stage 2 is so-called “Clock Time”; its duration is 30” and it starts at the end of Stage 1. An orange light is on during the whole stage.

No boats can be put on the water during Stage 2.

During stage 2, drivers have to drive their boats clockwise on the circuit in order to get to the starting line at the end of this stage, which coincides with the beginning of stage 3.

The end of stage 2 coincides with the effective beginning of the heat, whatever the position of competitors on the course. It is signaled by a flash located on the clock and by the harm on zero.

The heat is considered as effectively started when boats cross the starting line after the end of stage 2.

DDD Boats crossing the starting line before the end of stage 2 are considered as having taken an early start and must therefore complete the lap and cross again the starting line.

308.5.3- STAGE 3

Stage 3 is so-called "Course Time".

This stage consists in covering as many laps as possible within the pre-set race time.

After the end of race signal all boats on the course must complete the last lap and the additional race time is recorded for each competitor;

The competitors must run an extra lap at low speed to come back to their own position at the start pontoon;

The boat crossing the arrival line more than twice after the end-of-race signal will be penalized by as many laps as the ones unnecessary covered.

308.05.04 – OF-1 STARTING PROCEDURE

When the "Red Lights assembly" is available this start procedure should be preferred;

- Pit - time of 2 (two) minutes with Count-down; where the competitors may Start the engine and the boat may be put on the water but not released.
- 15 seconds to red lights sequence is announced.
- all the boats must be put on the water and kept in position by the pit mechanics.
- Turn-on sequence of 5 (five) RED Lights is started.
- The RACE START when, after a random delay of up to 5 seconds the 5 RED LIGHTS are turned –off simultaneously; only at this moment the boats on the water can be released (NOT LAUNCHED).
- boats must leave the starting pits straight toward buoy n.1 for the first right turn.

308.06 - PENALTIES

A driver infringing the rules is inflicted a penalty lap or disqualification for the heat in progress if he/she damages another competitor. The infringement and the penalties inflicted must be immediately notified by the Start Officer to the competitor.

A boat that rounds a buoy inside at any moment of the three stages incurs a 1 lap penalty for each buoy so fouled, a fouled buoy can be re-rounded to avoid penalty.

Touching one or several buoy involve no penalties.

Should an infringement be of a serious nature likely to damage competitors' hull, hurt spectators, etc. because of a willful violation of rules, the offender would be excluded from the competition in progress as well as from all other races that are to take place during the same event; this is subjected to a final judgment by the jury.

308.07 - COLLIDING WITH HULLS STOPPED ON THE COURSE

Colliding with a hull stopped on the course involves disqualification for the heat in progress.

Should a driver collide with a hull stopped on the course twice in the same event, he/she would be disqualified for the competition in progress as well as for all other races that are taking place during the same event.

309 - RACE CANCELLED

The Race Committee has the power to cancel any race should unfavourable weather or reasons of "force majeure" render this action necessary.

310 - RACE POSTPONED

310.01

The officer of the Day has the power to postpone the start even after the first signals have been given, but only in cases of “force majeure” or if an error in the starting signals has been made.

310.02

In both cases, signalling is to be recommenced. When the need for postponement is over, the Race Committee signals the start according to the instructions contained in the programme.

New entries are not to be accepted for postponed races.

Only drivers who duly entered and were present when the race was postponed are admitted.

311 - RACE STOPPED

A stopped race is a race that has been interrupted by the Officer of the Day after the start. Stopping the race is decided by the Officer of the Day for reasons of which he/she is the sole judge.

A boat that has committed an infringement to the rules (leading to a disqualification) in a stopped race is not allowed to start in the re-started race.

312 - RACING CONDUCTS - R.C. ENDURANCE SERIES

312.01 COURSE

During the race, competitors have to maintain their course, avoiding other boats. Should a competitor infringe this rule, he/she would be first blamed and in case he/she would do it again, he/she would be disqualified upon a decision by the Jury.

312.02 - BACK TO THE PIT

It is not allowed to drive a boat back to the pit by crossing the course. Infringing this rule involves an immediate disqualification of the competitor for the heat in progress.

312.03 - STARTING MODE

The boat starts from the pontoon on a line parallel to the direction of the race, leaving priority to those boats coming from the left.

312.04 - REVERSED NAVIGATION DIRECTION

U-turns are not allowed. Any infringement to this rule would lead to disqualification.

312.05 - ROUNDING AND FOULING MARKS

A competitor that does not cover the course regularly, missing one or several marks in the same lap, will be penalised by as many laps as the marks missed.

A mark that has been missed can be fouled again and then no penalty is incurred.

312.06 - RADIO FAILURES

The competitor who has remote control problems should raise his/her arms and state "RADIO FAILURE", enabling then the Judge to take note of the number of the boat, to advise other competitors with the loudspeaker and to decide on its retrieval if required.

312.07 - RETRIEVAL

During retrieval procedures, competitors have to be most careful to avoid endangering the people in charge of retrieval.

Speed must be reduced near the retrieving boat operating on the circuit.

Those infringing these rules will be blamed and in case they do it again of in case of collision, they will be disqualified by a final judgement by the jury.

A boat retrieved can resume the race during a final only.

A boat retrieved during an eliminating heat and/or a semi-final is not allowed on the water for the whole heat in progress.

312.08

To better understand items 312, see group 900 Annex C herein.

313 - RACING CONDUCT - R.C. HEAT RACING AND OFFSHORE SERIES

313.01

During stage 2 of start procedure, competitors should navigate in such a way that they will cross the starting line at full speed.

However, during the last five seconds of Stage 2, they can neither slow down nor alter their course when they have passed Buoy n° 6.

313.02

As a general rule, it is forbidden to suddenly alter one's course and the competitor with the inside position has the priority.

313.03

When overtaking another boat, the competitor will have to provide for a length equal to the size of no less than three boats before cutting in, in order to avoid obstructing the course of the competitor overtaken.

313.04

Fast turns to the left (except intended to avoid a collision) are forbidden. Slight corrections to the left are admissible, but only to overtake a competitor. A turn to the left over 45° may be considered as an infringement.

313.05

Should a boat damaged be unable to complete the heat, the driver of the boat who has committed the infringement is disqualified for the heat in progress.

313.06 - RADIO FAILURES

The competitor having problems with his/her radio control must immediately raise his/her arms and state "RADIO FAILURE" enabling then the judge to take note of the number of the boat, to advise other competitors with the loudspeaker about the boat which is in trouble.

313.07

For safety reasons, the retrieving boat will not navigate while boats are racing. Once the race is over, the retrieving boat can navigate and retrieve the boats that have been damaged or have had a breakdown.

During practice, the retrieving boat will navigate only if all boats are stopped.

The competitor putting his/her boat on the water while the retrieving boat is navigating will be excluded from any competition.

313.08

To better understand items 313.01 to 313.07, see group 903 (Annex C).

318 - SCORING SYSTEM

318.01

In Endurance competitions, a competitor has to complete no less than one validated lap to be scored.

318.02

The competitor who has had no valid result is not scored.

318.03

The official results must be posted on the notice board within an hour of the end of the races.

318.04

A general classification of different classes racing together is not permitted.

318.05

National classes may be raced at international meetings.

318.06

If boats of different series or classes start together, every boat must be classified in its own class.

When the programme for a meeting does not provide races for all classes, boats not provided for may race in the next higher class in the programme, subject to their acceptance by the Race Committee.

318.07

It is forbidden to take part in a race for a lower class than that to which a boat belongs, except with the written consent of all competitors.

The Race Committee may hold a race, as a separate class, for one design hulls equipped with identical engines.

319 - DEAD HEAT

319.01

Two boats are in dead-heat when :

- They cross the line together
- They obtain the same points in a points race
- They obtain the same ratings in a rating race

320 - POSTING OF THE RESULTS

The results of each race must be posted at the pits in clearly visible position.

The officer in charge must sign the results and state the hour of posting. The same officer has to be present for one hour so as to receive protests.

321 - INSPECTION OF HULLS AND ENGINES

321.01

Boats and engines taking part in a race which are subject to checking must not leave the boat park until an hour after the results have been posted.

321.02

For special cases (inspection of multi-cylinder engines and others involving the use of special tools and equipment) the Technical Officers postpone the inspection and stipulate the time and place where the engines must be available.

321.03

In the meantime, the engine must be sealed to prevent any alterations being made. Refusing to produce the engine or the hull entails disqualification.

321.04

The scrutineers are requested to dismantle the engines according to the correct practice and limit their inspections to the necessary parts.

Engines and boats will be placed pending inspection in well defined place which remains under the care of the “boat park” official. This is called the “parc fermé”.

321.05

After the pre-race technical inspection, the boats must not leave the boat park except for practising or racing.

321.06

If any repairs can only be effected outside the boat park, they must be carried out in the presence of the Technical Officer.

321.07

Officers allowed to attend the inspection :

- The Officer of the Day
- The delegate of the interested National Authority
- The measurers named by the Organising Committee
- The driver and a mechanic if necessary
- The UIM Observer
- The UIM Commissioners

The presence of other persons is only allowed if authorised by the Officer of the Day.

320 - PRIZES

322.01

A National Authority may ask to reduce the number of prizes according to the number of competitors. However, the value of the prizes must be maintained as provided for in the advance-programme. This possibility must be explained in the advance-programme.

322.02

Challenge to be competed for over several years :

if a competitor fulfils the conditions for winning the challenge definitely, he/she is awarded the challenge. If two or more competitors fulfil the conditions for winning the challenge, the holder shall be decided by drawing lots.

323 - AFTER THE MEETING (REPORTS)

323.01

At the end of the meeting, the Secretary of the Race Committee must send to the Radio Controlled Commission of his/her National Authority a report including :

- 323.1.1 Classification and distribution of prizes ;
- 323.1.2 Report by timekeepers
- 323.1.3 List of drivers
- 323.1.4 Penalties
- 323.1.5 Documents on any records broken in conformity with UIM rules
- 323.1.6 List of protests and decisions relating to the meeting or the race
- 323.1.7 All necessary documents in order to evaluate the meeting or the race

323.02

These documents must be sent to the Radio Controlled Commission of the National Authority within 8 days of the end of the meeting or the race.

323.03

After each titled meeting, the organisers must send the results to the Secretariat of UIM

323.04

If the results are taken into consideration for the granting of a trophy or a prize, the points must be sent to the UIM by cable within 48 hours.

323.05

20 days after a competition, the organising club must send the final results to the National Authorities of all participants and to the Secretariat of the Union.

GROUP 500 SERIES AND CLASSES

500 - SERIES AND CLASSES

500.01 - ENDURANCE

- ED 3.5 up to 3.50 cc
- ED 7.5 up to 7.50 cc
- ED 15 up to 15.00 cc
- ED 27 up to 27.00 cc with ignition only
- E 35 up to 35.00 cc with ignition only

500.02 - "HYDRO" HEAT RACING

- H 3.5 up to 3.50 cc
- H 7.5 up to 7.50 cc
- H 15 up to 15.00 cc
- H 27 up to 27cc with ignition only
- HF-1 up to 3.50 cc outboard engine (semi scale catamaran hull)
- HF- ¼ up to 15cc or up to 30.5 cc with ignition only Outboard engine or in-outboard power plant (semi scale catamaran hull)

500.03 - OFFSHORE

- O 3,5 up to 3,50cc
- O 7,5 up to 7,50cc
- O 15 up to 15cc
- O 27 up to 27cc with ignition only O 35 up to 35cc with ignition only
- OF-1 up to 3,50cc outboard engine (semi-scale catamaran hull)
- OF-¼ up to 15cc or up to 30.5 cc with ignition only out-board engine or in/out-board power plant (semi-scale catamaran hull)

502 - INSPECTIONS

502.01

Hulls, engines, fuel, accessories and equipment's, subject to restrictions regarding dimensions and other characteristics must be submitted for verification.

502.02

The competitor must report with his/her boat at the inspection jury who will stamp it.

In this purpose, the boats must be in good working condition and must be provided with a port of no less than 1.5 mm diameter on a non-eradicable side.

502.03

The driver must report with his/her boat at the inspection and must comply with the instructions given by the Race Committee.

502.04

Technical inspectors have the right, once races are over, to carry out all the checks they consider necessary even when the inspection has taken place before practice and they have the right to inspect as they think fit.

502.05

Drivers are at all times responsible for the condition of their boat.

502.06

Errors, if any on the part of the manufacturer, builder, mechanic or even the previous owner do not justify in any way non-conformity with the rules.

502.07

Any driver refusing to comply with the decisions of the Technical inspectors or who do not comply with the conditions of the rules, is not allowed to take part in a race, or should he/she have raced cannot be classified and penalties can be applied.

502.08 - SEMI-SCALE CATAMARAN HULL

The shape of the hull must be a catamaran circuit type.

The hull must have on the cockpit at least one graphic showing the windscreen of the cockpit; for hulls with open canopies there must be a driver wearing a helmet conforming with rule 502.03.07.11.

502.09 - OUTBOARD ENGINE

The outboard motor is a mechanical assembly which can be removed from the boat as a single unit, complete with its transmission and which does not transmit the power through the hull up any point. The motor thus taken off and placed ashore must be capable of being started.

Any mechanism intended to modify the angle of attachment and/or the height of the motor is authorized.

502.10 - IN-OUTBOARD POWER PLANT

It is meant that engine, possible reducer, exhaust silencer can be fixed on board of the hull, drive shaft crosses the transom, a dummy outboard engine must be installed outside the hull transom.

502.11 - ENGINE WITH IGNITION ONLY

It is meant an engine fuelled with green gasoline and oil mixture ignited by spark plug system.

502.12 - ENGINE

When not specified it is meant an engine fuelled with methanol and oil mixture with glow plug system. The use of nitromethane is allowed in full respect of the rules and countries laws in force.

503 - EXTRA BOAT

503.01

A second boat for each class may be scrutineered. Only one boat at a time may be taken to the start pontoon and it can be anymore changed once the start procedure of the heat or final is on-going.

503.02

One boat may be raced in different Classes, provided than all class requirements are fully met and scrutineered.

504 - NOISE REDUCTION

504.01

The use of an efficient device to attenuate the noise is compulsory.

504.02

The noise emitted by the boat cannot exceed the maximum limit of 80 dB(A).

504.03

The noise measurement is done with the boat on the water while racing by means of suitable and freshly calibrated noise level meter placed at 22 metres from the running boat.

Standard noise level measurements techniques should be used along with the noise level meter manufacturer precautions given in order to minimise the influence of the environment.

504.04

Should the exhaust pipe or the silencer break-down, the competitor has to move back to the pits immediately, following a regular course and must have it repaired. Should this rule be infringed, the competitor would be disqualified for the heat in progress. In Heat Racing, the boat has to go back immediately to the pits. It will start again only if the race is still in Stage I.

504.05

However, should the laws of the organising countries be more drastic, the latter will apply.

505 - REPLACEMENT OF MECHANICAL PARTS

Mechanical parts as well as radio control parts can be replaced (without changing the frequency declared).

510 - CALLING TIME

Once the calling time is over, the competitor loses his/her right to take part in the heat for which he/she had been called.

512 - HULLS

512.01

512.01.1- ENDURANCE CATEGORY

The hull and the bottom are free.

512.01.2- “FREE HULLS” HEAT RACING CATEGORY

The hull and the bottom are free.

512.01.3 - “HYDRO” HEAT RACING CATEGORY

HYDRO means a hull that is born by two or more surfaces being separated under water while the boat is racing.

512.02 - WEIGHTS AND LENGTHS

There is no weights limit.

The total length, everything included, should not exceed 1800 mm.

513 - MACHINERY

513.01

The type and number of engine is free, cylinder capacities being defined under item 500.

513.02

One or more propulsion devices or engines are allowed and the pushing effort must be applied in the water. The class is defined by adding the engines cylinder capacities.

513.03

The transmission and the use of multipliers, reducers, differentials, clutches, etc. are free.

520 - BREAKING OF RULES

520.01

Should a competitor break the rules, he/she will be liable to the following :

- disqualification of the boat (for infringement of class rules; in that case, results obtained in races will be cancelled and the competitor is excluded from the classification);
- disqualification of the competitor (for infringement of the rules on courses, maximum time, class, noise level, misbehaviour during a race).

Should the competitor or the mechanics behave in way that goes against the sporting spirit, the competitor would be reported to the R.C. Commission by the Officer of the Day.

During the race, the competitor and his/her mechanic have to comply with the provisions taken by the Jury and to have a correct behaviour vis-à-vis all the race Officers, other competitors and the public. Should they fail to do so, they would be disqualified and reported to the R.C. Commission.

530 - RETRIEVAL OF BOATS

530.01

The driver and his/her mechanic may retrieve their boats only from their stand on the pontoon. In such a case, they are authorised to use a tool whose total length does not exceed 1.20 m. Any infringement of this rule would lead to the disqualification of the competitor for the heat in progress.

The retrieval of dead boats is to be done only by people in charge of the retrieval.

540 - LEAVING THE PONTOONS

The competitor who leaves the pontoon with the boat during a heat or a final in progress is considered as withdrawing from the heat or the final in progress.

550 - FUEL

Fuel has to be provided by the competitor who is the sole responsible for its composition.

According to class/category rules the basic components for fuel are lubricating oil and METHANOL or GASOLINE as appropriate.

- For GASOLINE fuels the use of substances aimed to increase engine performances is NOT ALLOWED.
- For METHANOL fuels the use of Nitro-Methane is allowed up to 30% p.p. max. The race officials are entitled to make fuel tests at any time during the event.

According to UIM fuel testing procedures the test will be done by using an Automatic Digital Density Tester:

- The max allowed density reading for gasoline fuels is (0,775)
- The max allowed density reading for Methanol fuels is (0,890)

All readings are referred to a 20°C environmental test temperature.

Use of fuel not complying to Class/Category rules led to disqualification from the involved race.

P.S. - The use of substances (e.g. Nitro-methane) aimed to increase engine performance is regulated by the Class/Category rules and must be in compliance to the "U.E. rule N. 98/2013 of 02 January 2013" in which is stated that the content of substances must not exceed 30% p.p. in all U.E. Countries starting from 02 march 2016.

580 - TURBO-JETS AND ROCKET PROPELLED BOATS

580.01

Turbo-jet and rocket propelled boats are accepted as international series.

580.02

These boats are not entitled to race, though they can attempt world speed records.

580.03

Propulsion is according to the physical law which states that action and reaction are equal and opposite.

580.04

A rocket is an engine which burns two fuels other than air. These two fuels are combined so as to obtain a mass of gas which is rejected at high speed.

GROUP 700 ENVIRONMENTAL

700 - ENVIRONMENTAL

701 - NOISE LEVEL

Every driver is responsible that his/her engine(s) does not exceed established noise levels at all times. See rules 504

702 - EMISSIONS

To reduce emissions as much as possible, all drivers are recommended to use biodegradable lubrication oil.

703 - RE-FUELLING

Every care must be taken not to spill fuel or oil. An absorbent carpet to avoid any spillage on to the ground must be used.

704 - ENVIRONMENTAL CARE IN RACE AREAS

704.1

Every organiser must appoint a responsible person or persons to make necessary arrangements to control the environment of the whole race area including spectator areas.

704.2

There must be large containers in the pits where waste, such as cans, containers, oil waste can be placed.

One person must be responsible for this and to authorise the proper removal after the race meeting with the Local Authorities.

704.3

It is mandatory to inform the Drivers of all these environmental matters at the Drivers meeting (Rule 204.021).

GROUP 800

OTHER COMPETITIONS

800.01 - ELECTRIC COMPETITION

a - CATEGORIES

- a.1 - Multi Racing (MR)
- a.2 - Heat Racing (HR)

B - ENGINES

Any type of motors are allowed (including Cobalt magnets type). More than one motor are allowed on a boat.

C - BATTERY CELLS

The only battery cells allowed as motor supply are:

- NiMH (23 mm x 43 mm)
- S1P Lipo
- S2P LiFe Po4(A123)
- Lipo 2S1P – 2S2P – 3S1P – 3S2P
- Lipo 4S1P – 4S2P – 6S1P – 6S2P

There are no restrictions for supply of Radio-control device.

A Lipo Batteries Hard Case may be used but it must be possible for the Officials to easily check the Net Weight of the battery cells themselves.

The boat must be equipped with a device that allows measurement of the battery voltage, by the officials, when the boat is closed and ready to race.

D - HULLS

- d.1 - MR Classes : Any material, mono-hull only, submerged prop. Drive.
- d.2 - HR Classes : No restrictions.

E - PROPELLERS

Only water propellers allowed.

No restrictions on propeller material, number of blades, etc.

F - POWER DRIVE

No restrictions on type of drive (direct drive and/or gear boxes allowed in all classes).

G - SPEED CONTROL

Must be remotely operated by the Radio Control device.

It must be able to completely stop the engine.

No restrictions on how the control is achieved.

H - ONBOARD ENGINE POWER BREAKER DEVICE

It must be fitted externally on all boats and clearly marked ON/OFF.

J - RACE NUMBERS

A vertical plate must be provided on all boats (80 mm X 80 mm.).

Number should be BLACK on WHITE background. See Rule 902 - Fig 5

Race number to be decided by the organiser committee and to be communicated to the competitor at time of entry.

K - CLASSES

k.1 - (MR) Multi racing eco-expert

Race time 6 minutes

Course Triangle (30x30x30 meters - anti-clockwise turns)

N. of Cells up to 7 NiMH

up to 2 S1P Lipo (300 gr. Max)

up to 3 S2P LiFe Po4 (A123) (520 gr. Max)

Maximum allowed Voltage : 8, 5 Volts

k.2 - (HR) Oval 1

Race time 5 minutes

Course Oval (clockwise turns)

N. of Cells up to 7 NiMH

up to 2 S1P Lipo (300 gr. Max)

up to 3 S2P LiFe Po4 (A123) (520 gr. Max)

Maximum allowed Voltage : 8, 5 Volts

k.3 - (HR) Oval 2

Race time 5 minutes

Course Oval (clockwise turns)

N. of Cells from 8 to 12 NiMH

from 3 up to 4 S1P Lipo (590 gr. Max)

from 4 up to 5 S2P LiFe Po4 (A123) (860 gr. Max)

Maximum allowed Voltage : 17,0 Volts

k.4 - (HR) Oval 3

Race time 5 minutes

Course Oval (clockwise turns)

N. of Cells from 13 to 20 NiMH

from 5 up to 6 S1P Lipo (895 gr. Max)

from 6 up to 7 S2P LiFe Po4 (A123) (1200 gr. Max) Maximum allowed Voltage : 25,5 Volts

L - RACING COURSES

L.1 - Triangular type

See Art. 901.04 (fig.4) for Course layout Sizes : 30 x 30 x 30 meters

L.2 - Oval type

See Art. 901.05 (fig.4a) for Course layout

Normal sizes : Straights = 90 meters - Turns radius = 14.0 meters
Emergency sizes : Straights = 44 meters - Turn radius = 7.6 meters

M - NUMBER OF BOATS

A maximum of 6 boats are allowed in each heat. Only one driver for each boat is permitted.

N - NUMBER OF HEATS

When competitors in a Class are 6 or less:

Three heats are run - the two best results (laps and time) of each competitor are added - the total is the final result.

The competitor with the highest number of laps is the winner.

When competitors in a Class are more than 6: Groups are created with max of 6 competitors each, three qualifying

heats are run for each group,

the two best results (laps and time) of each competitor are added - the total is the qualifying result, no matter which group they belong to.

The 6 competitors with the highest number of laps will access to the final heat. A Competitor must complete at least one valid laps in order to be ranked.

Tie Breaks

In case of equal results (laps and time) at the end of the qualifying or final heats the discarded result has to be considered, If a tie still exist the best ranking will go to the competitors who got most first places finishes in raced heats, then the second place finishes, then third place finishes and so on. If a tie still exist after this process has been exhausted it shall be broken in favor of the higher placed boats from the last heats run.

In case of equal points at the end of the championship, the winner shall be decided by the most first places finish in races, then the second place finishes, then third place finishes and so on. If a tie still exist after this process has been exhausted it shall be broken in favor of the higher placed boats from the last race.

O - STARTING PROCEDURES

o.1 - Multi Racing

- a) call to the pits (2 minutes to complete the starting grid)
- b) Radio Controls check should be successfully performed
- c) 15 seconds to start is announced
- d) all the boats must be put on the water and kept in position by the pit mechanics
- e) 5 seconds to start is announced and then a second by second count down to GO
- f) boats must live the starting pits straight toward buoy n.2 for the first left turn

o.2 - Heat Racing

- a) call to the pits (2 minutes to complete the starting grid)
- b) Radio Control check should be successfully performed
- c) all the boats must be put on the water and kept in position by the pits mechanics
- d) at the START signal the boats may be launched
- e) boats must leave the starting pits straight towards buoy n.4 for the first right turn
- f) START signal is immediately followed by a 15 second count down announced as follows :

10, 8, 6, 5, 4, 3, 2, 1, GO
- g) boats not launched before 5 seconds announce are considered retired for that heat
- h) once entering the course a boat must keep going
- i) launched boats should manage not to cross the start line before the GO.

P - END OF RACES

At the end of the Race Time the STOP is announced. All boats on the course shall complete the lap they had begun prior the STOP announcement. The time to complete the lap after STOP is recorded for each boat and the lap is recorded as well.

The last lap is not scored if the time to complete it after STOP exceeds 60 seconds.

Q - PENALTIES

Early START, buoy jumping, stop the boat after launching it during H.R. starting procedure will lead to 1 lap penalty.

Hitting an identified dead boat on the course will lead to disqualification for the heat.

When this occurs, the disqualified boat must leave immediately the course whenever possible.

R - OTHER APPLICABLE RULES

For every situation not specifically addressed in this set of rules, the UIM Radio Controlled Rules are

applicable as appropriate.

Fig. 1 901.01 ENDURANCE COURSE

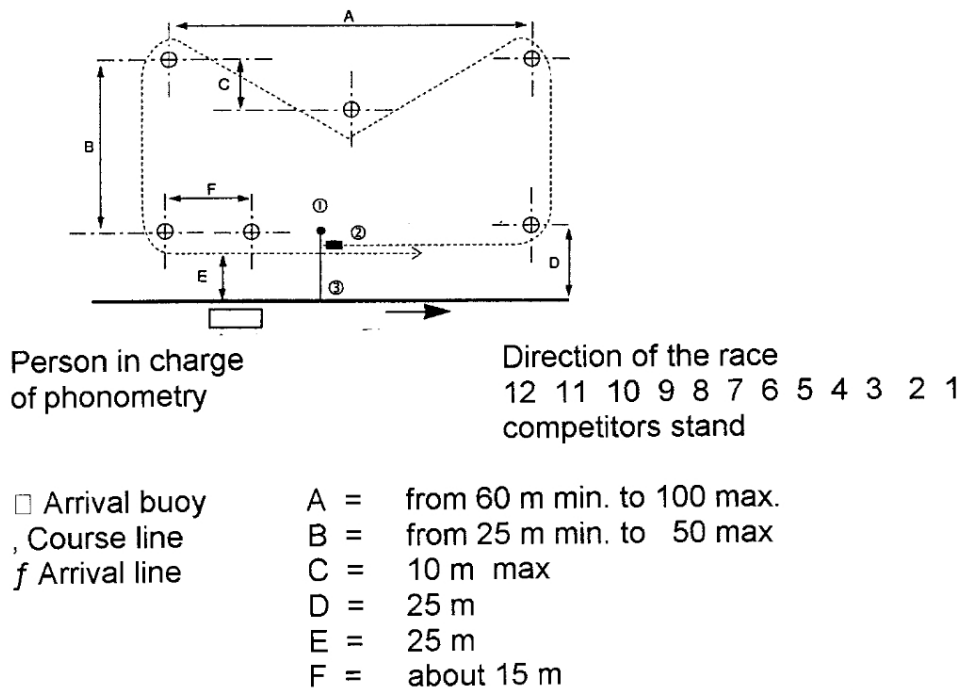

Note : a minimum clearance of 15 metres must be checked all around the course.

Fig. 2 901.02 HEAT RACING COURSE

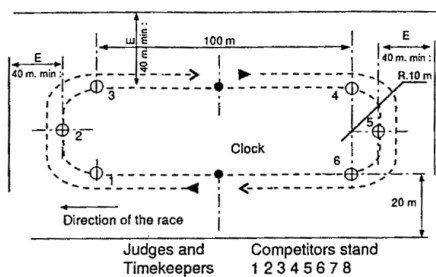

1 - 6 Course buoys
 Arrival buoy

Note : A minimum clearance of 40 metres must be checked all around the course.

Fig. 3 901.03 SPEED RECORD COURSE

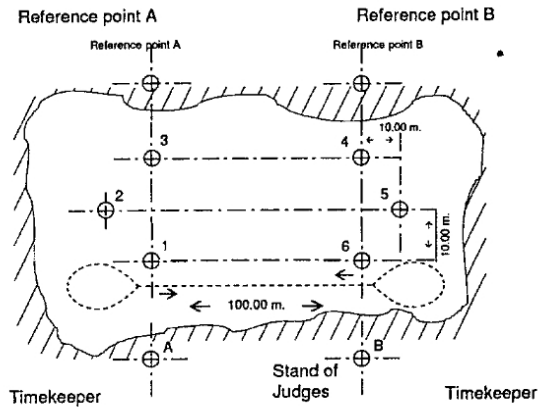
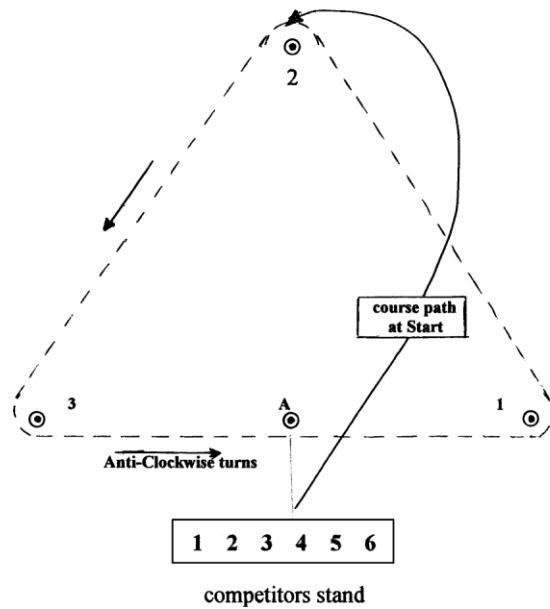
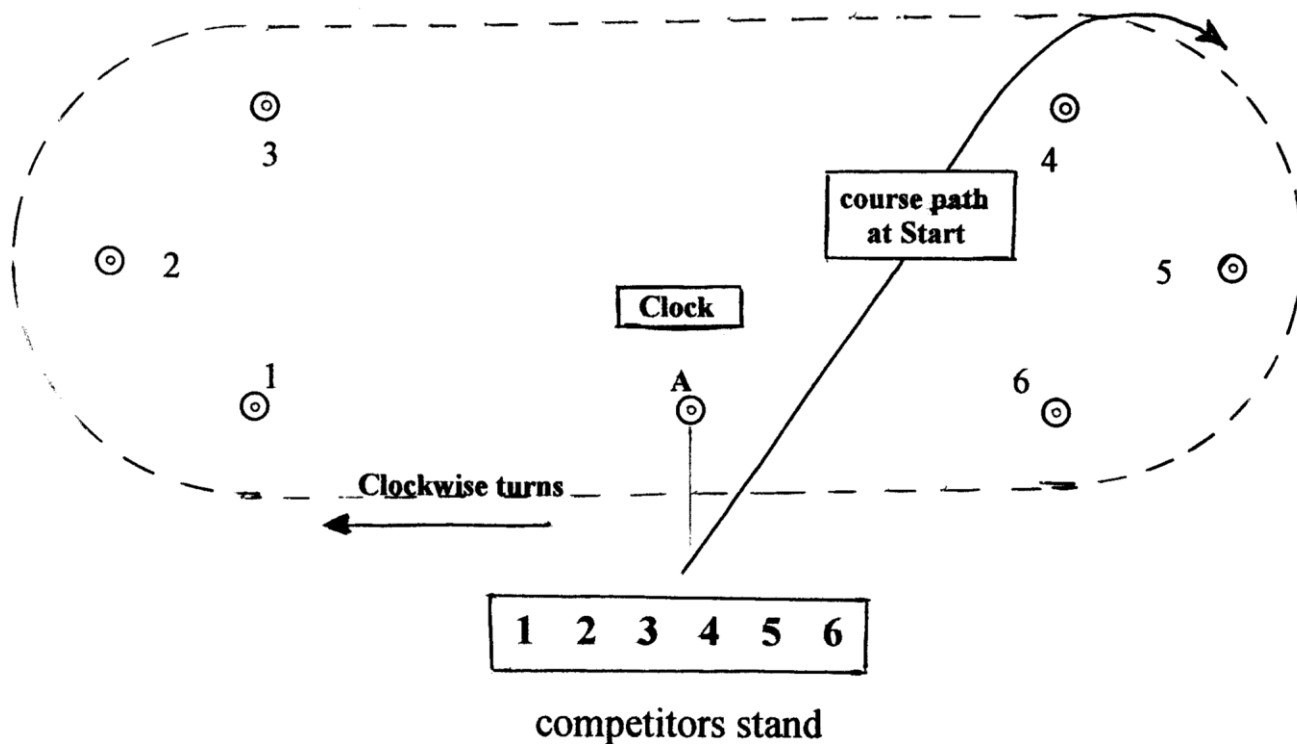

Fig. 4 901.04 ELECTRIC TRIANGLE COURSE



Straights : 30 + 30 + 30 meters
 Buoys 1, 2, 3 : Course buoys
 Buoy A : Arrival buoy
 Note : a minimum clearance of 15 meters must be checked all around the course

Fig. 4a 901.05 ELECTRIC OVAL COURSE



Standard : Straights - 90 meters / Turns radius – 14 meters.

Emergency: Straights - 44 meters / Turns radius – 7,6 meters

Buoys 1, 2, 3, 4, 5, 6 : Course buoys

Buoy A : Arrival buoy

Note: a minimum clearance of 30 meters must be checked all around the course

Fig. 5 902 RACING NUMBER PLATES

a. Endurance and Offshore

Black number on White background 100x140 mm

Numbers Height: Minimum 75 mm Maximum 80 mm

Numbers Width: Minimum 30 mm (except for n° 1)

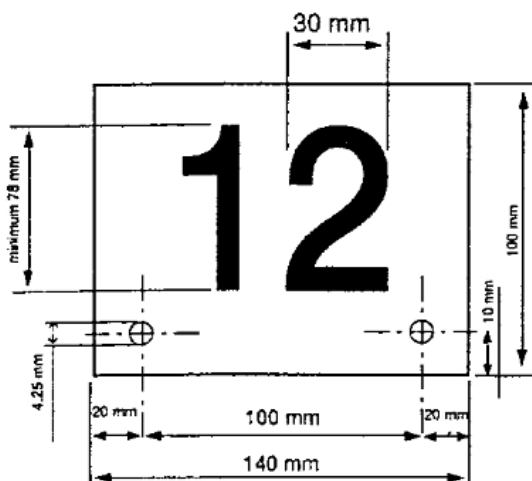

b. Heat racing , electric boat and OF-1 class

Black number on White background 80x80 mm

Numbers Height: Minimum 65 mm

Numbers Width: Minimum 25 mm (except for N° 1)

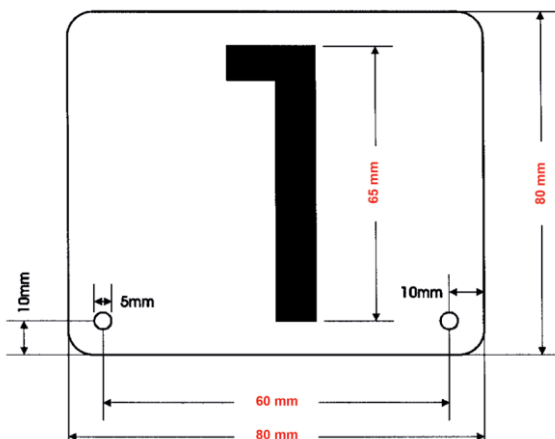
**801 – SOLAR CELL**

Technical specifications will be settled as soon as the experimental test will be completed.

802 – MARATHON RACE**802.01 – INDIVIDUAL RACE****802.01.01 – CLASS ALLOWED**

Ref. Art. 501.01

802.01.02 – FORMAT RACE**A - DURATION RACE : 2 HOUR**

dead boats are retrieved and may restart.

B – PIT-STOP

Any driver during the race can stop to make changes to the boat and refuel.

C - CLASSIFICATION

The classification is established on the basis of the number of laps completed by each boat, from the starting signal up to the end-of-race signal, penalties deducted if any.

For the rest, reference is made to Art. 110 to follow.

802.02 – 2 DRIVERS TEAM RELAY RACE**802.02.01 – CLASSES ALLOWED**

Ref. Art. 501.01

802.02.02 – FORMAT RACE**A - DURATION RACE : 2 HOUR**

Dead boats are retrieved and may restart.

B - TEAM COMPOSITION : 2 DRIVER and 2 BOAT

For each team there may be only one boat in water at a time.

C – DRIVER AND BOAT CHANGE

The pilot and boat change can only take place if the competing boat stops for a failure or for regular arrival at the jetty start .

D - PIT-STOP

Any drivers during the race can stop to make changes to the boat and refuel.

E - CLASSIFICATION

The classification is established on the basis of the number of laps completed by the two boats of the team, from the starting signal up to the end-of-race signal, penalties deducted if any.

F - RED CARD

If the driver receives a red card, he/she and his/her boat can not continue the race; other team member can go on to complete the race.

For the rest, reference is made to Art. 110 to follow.

802.03 – 3 DRIVERS TEAM RELAY RACE**802.03.01 - CLASSES ALLOWED**

Ref. Art. 501.01

802.03.02 - FORMAT RACE**A - DURATION RACE : 6 HOUR**

Dead boats are retrieved and may restart.

B - TEAM COMPOSITION : 3 DRIVER and 3 BOAT

for each team there may be only one boat in water at a time.

C – DRIVER AND BOAT CHANGE

the pilot and boat change can only take place if the competing boat stops for a failure or for regular arrival at the jetty start .

D - PIT-STOP

Any drivers during the race can stop to make changes to the boat and refuel.

E - CLASSIFICATION

the classification is established on the basis of the number of laps completed by the three boats of the team, from the starting signal up to the end-of-race signal, penalties deducted if any.

F - RED CARD

If the driver receives a red card, he/she and his/her boat can not continue the race; other team members can go on to complete the race.

for the rest, reference is made to Art. 110 to follow.

ANNEX C 903 - REF. RULES 312 AND 313

BREACH OF THE RULES

Rules set forth hereunder are mandatory. Any failure to comply with them will be considered as a breach and will lead immediately to a reprimand, a lap penalty or disqualification for the race.

a) Turns

Sharp turns are not allowed, except to avoid a collision. A slight correction may be required to overtake a boat but a turn exceeding 45° during the race is considered as a breach of rules.

Should a sharp turn cause a competitor to overturn, the person having committed the fault would have one lap penalty.

Should the boat so overturned break down in such a way that it cannot resume the race, the person having committed the fault would be disqualified for the heat.

b) Rules of the road

1. A boat following its course on the circuit must be able to keep it without having its way obstructed by other competitors trying to interfere.

A boat wishing to overtake another boat and to race on its lane must cover a length corresponding to no less than three boats before cutting in.

2. During a race, the natural course is the one which the most similar to the course drawn.
3. The above-listed rules also apply to turns.
4. Driving and sporting rules require that water lanes or courses be kept. Zigzagging or any other action aimed at preventing or obstructing the way to an overtaking competitor is considered as an infringement to the rule by the said boat.
5. Any failure to comply with these rules are breaches and lead to penalty laps.

c) Overtaking

Overtaking is allowed anywhere on the circuit provided rules set forth in Chapter “ a “ (turns) and “ b” (rules of the road) are being complied with. Examples are given hereafter.

Drawing n° 1 : Boat n° 1 has the right of way. Boat 2 and 3 try to incorrectly overtake it. Boat n° 2 cuts the course of boat n° 1. This is a breach of rules. Boat n° 3 tries to get closer from the inside, it has to turn left and cuts the course of boat n° 1 to avoid the buoy. This is a breach of rules.

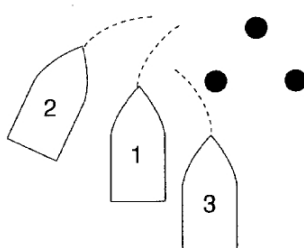

Drawing n° 2 : Boat n° 2 overtakes correctly. If a boat overtakes another and keeps its course in such a way that it covers the length of three boats before cutting in it acts correctly.

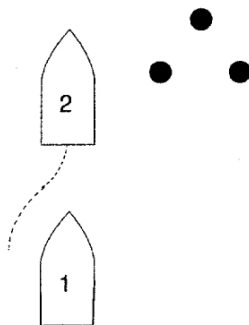

Drawing n° 3 : This procedure also applies to turns . N° 2 is to be penalised. Note that n° 1 has to cut in towards the buoy to avoid a foreseen collision. N° 2 breaks the rules.

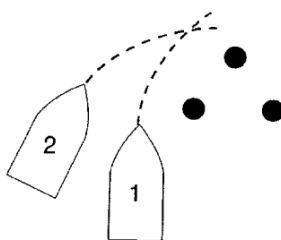

Drawing n° 4 : N° 2 turns and provides much space between itself and the other boat. N° 1 does not have to cut in towards the buoy. No breach.

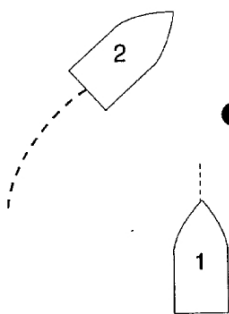

Drawing n° 5 : In this case, competitor 1 leaves its course by turning off far, making it possible for the other driver to take up its course by turning sharp. There is no breach. Now n° 2, at point « X », is on the right course.

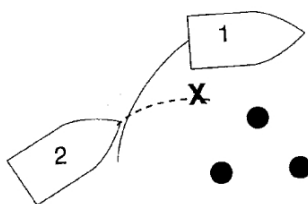

© (2024) Copyright by UIM - Union Internationale Motonautique. All rights reserved. No part of this document/publication may be reproduced, distributed, or transmitted in any form or by any means without the prior written consent of the UIM, except for the non-commercial use within the scope of authority of the UIM and its affiliated members.



CODE OF ETHICS 2024

TABLE OF CONTENTS

CODE OF ETHICS	185
THE ETHICAL PILLARS OF THE UIM.....	187
1.1 Equality	187
1.2 Fair play	187
1.3 Respect.....	187
1.4 Integrity	188
1.4.1 Conflicts of interest	188
1.5 Environment.....	189
2. GENERAL CONDUCT REGULATIONS.....	190
2.1 Basic Rules	190
2.2 Representational Duties	190
2.3 Conduct Towards Government and Private Organizations	190
2.4 Ban on Discrimination.....	190
2.5 Eligibility and Dismissal	190
2.6 Protection of Personal Rights	190
2.7 Loyalty and Confidentiality.....	190
3. PROCEEDINGS	191
4. ENFORCEMENT	191

1. PREAMBLE

The UIM is committed to the highest standards of conduct in sport administration and competition. To meet this commitment, the UIM has developed a Code of Ethics to express the core values of both the organisation and the sport of Powerboating. Such values and ethics underpin the UIM's policies, procedures and rules. Observance of the code is vital to the integrity of Powerboating. The UIM Code of Ethics is inspired to the ethical principles of the Olympic Movement of which the UIM is member.

The UIM Code of Ethics comprises five pillars. It imposes obligations in terms of respect and responsibility to competitors, teams, promoters, participants and all other UIM accredited persons.

This Code shall apply to all UIM members (either national federation or any other similar affiliated entity), UIM staff, persons elected or appointed to any position within the organization of the UIM or the Continental Organizations, and other individuals engaged in UIM activities, including drivers, competitors, team managers, team members etc. (collectively referred to herein as "Participants"). It shall also apply to consultants and contractually connected persons/firms, including those representing or serving UIM.

Unless otherwise specified, infringements are punishable regardless of whether they have been committed deliberately or negligently.

Acts amounting to attempted infringements are also punishable. In the case of acts amounting to attempted infringements, the Executive Committee may reduce the sanction envisaged for the actual infringement accordingly. It will determine the extent of the mitigation as it sees fit; it shall not go below the general lower limit of the fine applicable to the concerned infringement.

The fact that a natural person is not anymore a member of the UIM or has left a member of the UIM neither cancel out liability nor prevents from carrying out disciplinary proceedings. The same provision applies to legal persons members of the UIM.

THE ETHICAL PILLARS OF THE UIM

1.1 Equality

Discrimination and harassment against others on grounds of race, disability, marital status, sex, sexuality, age, political or religious conviction are not condoned in Powerboating.

All forms of harassment, be they physical, mental, professional or sexual, are strictly prohibited. Powerboating promotes the inclusion of men and women equally.

1.2 Fair play

Fair play is the guiding principle in the sport of Powerboating. All Participants taking part in Powerboating shall behave with fairness and honesty.

All Participants shall operate within and abide by the rules of the sport.

All doping practices at all levels are strictly prohibited. The provisions against doping in the Anti-Doping Code shall be scrupulously observed. Powerboating is committed to be a drug free sport.

1.3 Respect

Powerboating shall be characterised by mutual respect and self-responsibility. All Participants involved in powerboating shall be treated with dignity.

The contribution that people make to the sport shall be recognised.

In pursuing the sport's goals, the governance of Powerboating shall be mindful of the physical and psychological well-being of its members.

Violence and abusive behaviour are not tolerated.

1.4 Integrity

All persons subject to this Code shall use due care and diligence in fulfilling their roles for, and on behalf of, the UIM or Powerboating in general.

Decisions by the UIM will be made in accordance with established procedures, objectively, fairly and with honesty and integrity.

Conflicts of interest must be avoided.

1.4.1 Conflicts of interest

In discharging their duties to UIM, all Participants shall act for the benefit of UIM when making decisions that affect, or may affect, UIM and to do so without reference to their own personal interests, either financial or otherwise.

When performing an activity for UIM or before being elected or appointed, the candidate or Participant shall disclose to the Executive Committee any personal interests that could be linked with their prospective UIM activities. The Executive Committee may draw the attention of the candidate or Participant to potential conflicts of interest that it identifies.

Participants shall avoid any situation that could lead to conflicts of interest. Potential conflicts of interest arise:

- a) If Participants have, or appear to have, private or personal interests that detract from their ability to perform their duties with integrity in an independent and purposeful manner. Private or personal interests include gaining any possible advantage for the persons bound by this Code themselves, their family, relatives, friends and acquaintances;
- b) If the opinion or decision of an Official, acting alone or within an organisation, is influenced by, or may be reasonably considered as liable to be influenced by relations that such Official has, has had or is on the point of having, with another person or organisation that would be affected by the person's opinion or decision;
- c) If an Official is also involved in the executive day to day running of Continental/National federations of powerboating sports.

In the following non-exhaustive list of examples, the circumstances in which a conflict of interests could arise are personal and/or material involvement (salary, shareholding, various benefits) with:

- a) Suppliers of the party concerned;
- b) Sponsors, broadcasters, various contracting parties;
- c) Organisations liable to benefit from the assistance of the party concerned (including subsidy, approval clause or election).

Participants shall not perform their duties in matters with an existing or potential conflict of interest. Should a conflict of interest, or the appearance of a conflict of interest, arise, or if there is a danger of such conflict arising, the individual concerned must refrain from taking any further part in the handling of the matter. If it is unclear whether such a conflict of interest exists in any given situation, the matter may be submitted to the Ethics Panel.

If an objection is made concerning an existing or potential conflict of interest of a Participant, it shall be reported immediately to the Ethics Panel for appropriate measures.

If an Official neglects to declare a situation of a potential conflict of interest, any interested party in the UIM may refer the matter to the Executive Committee. When such a situation regards the President or any member of the Executive Committee, the member concerned shall abstain from taking part in the meetings of the Executive Committee where his/her position is to be adjudged, without prejudice of his/her right of defence.

1.4.2 Corruption

No Participant shall, directly or indirectly, solicit, accept or offer any concealed remuneration, commission, gifts, benefit or service of any nature connected with their participation in powerboating activities or with their function as an Official.

No Participant shall, directly or indirectly bribe or attempt to bribe third parties or urge or incite others to do so in order to gain an advantage for them or a third party.

No Participant shall solicit or accept benefits, entertainment or gifts in exchange for, or as a condition of, the exercise of their duties, or as an inducement for performing an act associated with their duties or responsibilities, except that gifts, hospitality or other benefits associated with their official duties and responsibilities may be accepted if such gifts, hospitality or other benefits:

- a) Are within the bounds of propriety, a normal expression of courtesy, or within the normal standards of hospitality;
- b) Would not bring suspicion on the Official's objectivity and impartiality; and
- c) Would not compromise the integrity of UIM.

No Participant may be involved with any company, association, firm or person whose activity is inconsistent with the objectives or interests of UIM. If it is unclear, whether this kind of a connection exists in any given situation, the matter shall be submitted to the Executive Committee for a decision.

1.4.3 Betting

Anyone subject to this Code shall not bet on Powerboating either directly or indirectly and shall not use any privileged, sensitive or inside information they may have in order to profit or facilitate third persons to profit from such information.

Anyone subject to this Code shall not perform corrupt practices relating to the sport of Powerboating, including improperly influencing either the course of an event (partially or entirely) or the outcomes and results of an event or race.

Anyone subject to this Code is forbidden from having stakes, either actively or passively, in any entity or, organization that promotes, brokers, arranges or conducts such activities or transactions.

Anyone subject to this Code shall exercise due care and diligence in fulfilling their roles for, or on behalf of UIM and not disclose information received if such disclosure is made maliciously in order to damage the interests of UIM or to obtain an unjust advantage or profit.

No UIM staff, governance bodies and other committee or commission member shall make adverse comments on a policy adopted by the UIM once the UIM decision has been taken.

1.5 Environment

The UIM is committed to raise environmental performance of power boating and make our sport a vector of environmental protection and sustainable development.

UIM looks to youth to breed a future for sportsmanship and safety while nurturing a passion and respect for water and its environment.

The UIM will promote the optimal use of resources and materials, efficient logistics and transport, reduction of polluting discharges to water and emissions to air.

2. GENERAL CONDUCT REGULATIONS

2.1 Basic Rules

All Participants shall show commitment to an ethical attitude while fulfilling their task. They shall pledge to behave in accordance with the ethical pillars of the UIM.

Participants may not abuse their position as part of their function in any way, especially to take advantage of their function for private aims or gains.

2.2 Representational Duties

Participants shall represent UIM honestly, respectably and with integrity.

2.3 Conduct Towards Government and Private Organizations

In dealings with government institutions, national and international organizations, associations and groupings, Participants shall, in addition to observing the basic rules of art.2.1, remain politically neutral, in accordance with the principles and objectives of UIM and act in a manner compatible with their function and integrity.

2.4 Ban on Discrimination

Participants may not act in a discriminatory manner, especially with regard to ethnicity, race, culture, politics, religion, gender or language.

2.5 Eligibility and Dismissal

Only those persons who demonstrate a high degree of ethics and integrity and pledge to observe the provisions of this Code without reservation are eligible to serve as UIM officials. Anyone who do not comply with these conditions are either no longer eligible or shall be removed from office.

2.6 Protection of Personal Rights

During the course of their activities, Participants shall ensure that the personal rights of those persons whom they contact and with whom they deal are protected, respected and safeguarded.

2.7 Loyalty and Confidentiality

While performing their duties, participants shall remain loyal to UIM Depending on their function, any information divulged to officials during the course of their duties shall be treated as confidential. Any information or opinions shall be passed on in accordance with the principles and objectives of UIM.

3. PROCEEDINGS

The UIM Executive Committee shall have exclusive jurisdiction on any infringement of the rules contemplated in this Code. Anyone who has interest can refer to the UIM Executive Committee the infringement of this Code of Ethics. Proceedings before the UIM Executive Committee shall be without particular formalities, provided that the right of defence and the principles of fair process are always respected.

The UIM Executive Committee appoints an investigator, who may, but not necessarily has to a member of the Executive Committee. The Investigator shall investigate the case and deliver to the UIM Executive Committee a written report. Such report shall be sent to the party or the parties concerned, with an invitation to submit defensive briefs and appear before the Executive Committee at the discussion hearing.

At the discussion hearing parties may be assisted by an attorney. The Executive Committee members and the appointed Investigator may attend the hearing also by video or tele-conference.

The infringements of the rules of this Code shall be sanctioned as follows:

- i) First violation, up to six months suspension and up to Euro 5,000 fine;
- ii) Second violation, from six months up to two years suspension and from Euro 5,000 up to Euro 10,000 fine;
- iii) Third violation, life ban and Euro 15,000 fine;
- iv) Highly serious infringements shall be sanctioned with no less than a two year suspension and then Euro 15,000 fine.

Should the infringement be committed by a consultant or any other contracted party of the UIM, the relevant contract shall be immediately terminated *de iure*.

Should the infringement be committed to obtain an illicit benefit, including sport outcomes, the relevant results, such as titles, prizes etc. shall not be awarded or revoked if already awarded.

The Executive Committee may reduce the sanctions envisaged for each actual infringement in accordance with the extent of the mitigation as it sees fit. In any event the sanction shall not go below the general lower limit of the fine applicable to the concerned infringement.

The parties to the proceedings shall keep strictly confidential and shall not disclose any information received or appraised during the proceedings. The decision taken by the UIM Executive Committee shall be published on the UIM website. The sanctioned party shall have 21 days as of the publication of the decision on the UIM website to appeal the decision before the Court of Arbitration for Sport in Lausanne.

4. ENFORCEMENT

This Code of Ethics is an integral and binding part of the UIM By-Laws and has entered into force and is fully effective since approval by the General Assembly on 26th October 2014.



ANTI-DOPING RULES 2024

TABLE OF CONTENTS

ANTI-DOPING RULES 2024	192
INTRODUCTION.....	194
ARTICLE 1 DEFINITION OF DOPING.....	196
ARTICLE 2 ANTI-DOPING RULE VIOLATIONS	196
ARTICLE 3 PROOF OF DOPING	199
ARTICLE 4 THE PROHIBITED LIST.....	201
ARTICLE 5 TESTING AND INVESTIGATIONS.....	205
ARTICLE 6 ANALYSIS OF SAMPLES.....	208
ARTICLE 7 RESULTS MANAGEMENT: RESPONSIBILITY, INITIAL REVIEW, NOTICE AND PROVISIONAL SUSPENSIONS.....	210
ARTICLE 8 RESULTS MANAGEMENT: RIGHT TO A FAIR HEARING AND NOTICE OF HEARING DECISION	213
ARTICLE 9 AUTOMATIC DISQUALIFICATION OF INDIVIDUAL RESULTS	215
ARTICLE 10 SANCTIONS ON INDIVIDUALS	215
ARTICLE 11 CONSEQUENCES TO TEAMS	225
ARTICLE 12 SANCTIONS BY the UIM AGAINST OTHER SPORTING BODIES.....	225
ARTICLE 13 RESULTS MANAGEMENT: APPEALS	226
ARTICLE 14 CONFIDENTIALITY AND REPORTING	229
ARTICLE 15 IMPLEMENTATION OF DECISIONS	233
ARTICLE 16 STATUTE OF LIMITATIONS	234
ARTICLE 17 EDUCATION	234
ARTICLE 18 ADDITIONAL ROLES AND RESPONSIBILITIES OF NATIONAL AUTHORITIES 234	
ARTICLE 19 ADDITIONAL ROLES AND RESPONSIBILITIES OF the UIM.....	235
ARTICLE 20 ADDITIONAL ROLES AND RESPONSIBILITIES OF ATHLETES.....	236
ARTICLE 21 ADDITIONAL ROLES AND RESPONSIBILITIES OF ATHLETE SUPPORT PERSONNEL 236	
ARTICLE 22 ADDITIONAL ROLES AND RESPONSIBILITIES OF OTHER PERSONS SUBJECT TO THESE ANTI-DOPING RULES	237
ARTICLE 23 INTERPRETATION OF THE CODE	237
ARTICLE 24 FINAL PROVISIONS.....	237
APPENDIX 1 DEFINITIONS.....	239

INTRODUCTION

Preface

These Anti-Doping Rules are adopted and implemented in accordance with the UIM's responsibilities under the *Code*, and in furtherance of the UIM's continuing efforts to eradicate doping in sport.

These Anti-Doping Rules are sport rules governing the conditions under which sport is played. Aimed at enforcing anti-doping rules in a global and harmonized manner, they are distinct in nature from criminal and civil laws. They are not intended to be subject to or limited by any national requirements and legal standards applicable to criminal or civil proceedings, although they are intended to be applied in a manner which respects the principles of proportionality and human rights. When reviewing the facts and the law of a given case, all courts, arbitral tribunals and other adjudicating bodies should be aware of and respect the distinct nature of these Anti-Doping Rules, which implement the *Code*, and the fact that these rules represent the consensus of a broad spectrum of stakeholders around the world as to what is necessary to protect and ensure fair sport.

As provided in the *Code*, the UIM shall be responsible for conducting all aspects of *Doping Control*. Any aspect of *Doping Control* or anti-doping *Education* may be delegated by the UIM to a *Delegated Third Party*, such as the International Testing Agency (ITA), however, the UIM shall require the *Delegated Third Party* to perform such aspects in compliance with the *Code*, *International Standards*, and these Anti-Doping Rules. The UIM may delegate its adjudication responsibilities and *Results Management* to the CAS Anti-Doping Division.

When the UIM has delegated its responsibilities to implement part or all of *Doping Control* to the ITA or to any other *Delegated Third Party*, any reference to the UIM in these *Rules* should be intended as a reference to the ITA or to the other *Delegated Third Party*, where applicable and within the context of the aforementioned delegation. The UIM shall always remain fully responsible for ensuring that any delegated aspects are performed in compliance with the *Code*.

Italicized terms in these Anti-Doping Rules are defined terms in Appendix 1.

Unless otherwise specified, references to Articles are references to Articles of these Anti-Doping Rules.

Fundamental Rationale for the *Code* and the UIM's Anti-Doping Rules

Anti-doping programs are founded on the intrinsic value of sport. This intrinsic value is often referred to as "the spirit of sport": the ethical pursuit of human excellence through the dedicated perfection of each *Athlete's* natural talents.

Anti-doping programs seek to protect the health of *Athletes* and to provide the opportunity for *Athletes* to pursue human excellence without the *Use of Prohibited Substances and Methods*.

Anti-doping programs seek to maintain the integrity of sport in terms of respect for rules, other competitors, fair competition, a level playing field, and the value of clean sport to the world.

The spirit of sport is the celebration of the human spirit, body and mind. It is the essence of Olympism and is reflected in the values we find in and through sport, including:

- Health
- Ethics, fair play and honesty
- *Athletes'* rights as set forth in the *Code*
- Excellence in performance
- Character and *Education*
- Fun and joy
- Teamwork
- Dedication and commitment
- Respect for rules and laws
- Respect for self and other *Participants*
- Courage
- Community and solidarity

The spirit of sport is expressed in how we play true.

Doping is fundamentally contrary to the spirit of sport.

Scope of these Anti-Doping Rules

These Anti-Doping Rules shall apply to:

- (a) the UIM, including its board members, directors, officers and specified employees, and *Delegated Third Parties* and their employees, who are involved in any aspect of *Doping Control*;
- (b) each of its *National Authorities*, including their board members, directors, officers and specified employees, and *Delegated Third Parties* and their employees, who are involved in any aspect of *Doping Control*;
- (c) the following *Athletes*, *Athlete Support Personnel* and other *Persons*:
 - (i) all *Athletes* and *Athlete Support Personnel* who are members of the UIM, or of any *National Authority*, or of any member or affiliate organization of any *National Authority* (including any clubs, teams, associations, or leagues);
 - (ii) all *Athletes* and *Athlete Support Personnel* who participate in such capacity in *Events*, *Competitions* and other activities organized, convened, authorized or recognized by the UIM, or any *National Authority*, or by any member or affiliate organization of any *National Authority* (including any clubs, teams, associations, or leagues), wherever held;
 - (iii) any other *Athlete* or *Athlete Support Personnel* or other *Person* who, by virtue of an accreditation, a license or other contractual arrangement, or otherwise, is subject to the authority of the UIM, or of any *National Authority*, or of any member or affiliate organization of any *National Authority* (including any clubs, teams, associations, or leagues), for purposes of anti-doping; and;
 - (iv) *Athletes* who are not regular members of the UIM or of one of its *National Authorities* but who want to be eligible to compete in a particular *International Event*.

Each of the abovementioned *Persons* is deemed, as a condition of his or her participation or involvement in the sport, to have agreed to and be bound by these Anti-Doping Rules, and to have submitted to the authority of the UIM to enforce these Anti-Doping Rules, including any *Consequences* for the breach thereof, and to the jurisdiction of the hearing panels specified in Article 8 and Article 13 to hear and determine cases and appeals brought under these Anti-Doping Rules.¹

Within the overall pool of *Athletes* set out above who are bound by and required to comply with these Anti-Doping Rules, the following *Athletes* shall be considered to be *International-Level Athletes* for the purposes of these Anti-Doping Rules, and, therefore, the specific provisions in these Anti-Doping Rules applicable to *International-Level Athletes* (e.g., *Testing*, *TUEs*, whereabouts, and *Results Management*) shall apply to such *Athletes*:

- (a) *Athletes* who hold the following license: UIM Superlicence, UIM Serieslicence;
- (b) *Athletes* who compete in any of the following *International Events*: UIM World Championship or Cup, UIM Continental Championships,
- (c) *Athletes* included in the UIM *Registered Testing Pool*, *Testing Pool* and any other Pool established by UIM;

¹ [Comment: Where the Code requires a Person other than an Athlete or Athlete Support Person to be bound by the Code, such Person would of course not be subject to Sample collection or Testing, and would not be charged with an anti-doping rule violation under the Code for Use or Possession of a Prohibited Substance or Prohibited Method. Rather, such Person would only be subject to discipline for a violation of Code Articles 2.5 (Tampering), 2.7 (Trafficking), 2.8 (Administration), 2.9 (Complicity), 2.10 (Prohibited Association) and 2.11 (Retaliation). Furthermore, such Person would be subject to the additional roles and responsibilities according to Code Article 21.3. Also, the obligation to require an employee to be bound by the Code is subject to applicable law.]

The UIM shall ensure that, as per Article 19 of these Anti-Doping Rules, any arrangements with their board members, directors, officers, and specified employees, as well as with the *Delegated Third Parties* and their employees – either employment, contractual or otherwise – have explicit provisions incorporated according to which such Persons are bound by, agree to comply with these Anti-Doping Rules, and agree on the UIM's authority to solve the anti-doping cases.]

ARTICLE 1 DEFINITION OF DOPING

Doping is defined as the occurrence of one or more of the anti-doping rule violations set forth in Article 2.1 through Article 2.11 of these Anti-Doping Rules.

ARTICLE 2 ANTI-DOPING RULE VIOLATIONS

The purpose of Article 2 is to specify the circumstances and conduct which constitute anti-doping rule violations. Hearings in doping cases will proceed based on the assertion that one or more of these specific rules have been violated.

Athletes or other *Persons* shall be responsible for knowing what constitutes an anti-doping rule violation and the substances and methods which have been included on the *Prohibited List*.

The following constitute anti-doping rule violations:

2.1 Presence of a Prohibited Substance or its Metabolites or Markers in an Athlete's Sample

- 2.1.1** It is the *Athletes'* personal duty to ensure that no *Prohibited Substance* enters their bodies. *Athletes* are responsible for any *Prohibited Substance* or its *Metabolites* or *Markers* found to be present in their *Samples*. Accordingly, it is not necessary that intent, *Fault*, *Negligence* or knowing *Use* on the *Athlete's* part be demonstrated in order to establish an anti-doping rule violation under Article 2.1.²
- 2.1.2** Sufficient proof of an anti-doping rule violation under Article 2.1 is established by any of the following: presence of a *Prohibited Substance* or its *Metabolites* or *Markers* in the *Athlete's* A *Sample* where the *Athlete* waives analysis of the B *Sample* and the B *Sample* is not analysed; or, where the *Athlete's* B *Sample* is analysed and the analysis of the *Athlete's* B *Sample* confirms the presence of the *Prohibited Substance* or its *Metabolites* or *Markers* found in the *Athlete's* A *Sample*; or where the *Athlete's* A or B *Sample* is split into two (2) parts and the analysis of the confirmation part of the split *Sample* confirms the presence of the *Prohibited Substance* or its *Metabolites* or *Markers* found in the first part of the split *Sample* or the *Athlete* waives analysis of the confirmation part of the split *Sample*.³
- 2.1.3** Excepting those substances for which a *Decision Limit* is specifically identified in the *Prohibited List* or a *Technical Document*, the presence of any reported quantity of a *Prohibited Substance* or its *Metabolites* or *Markers* in an *Athlete's* *Sample* shall constitute an anti-doping rule violation.
- 2.1.4** As an exception to the general rule of Article 2.1, the *Prohibited List*, *International Standards* or *Technical Documents* may establish special criteria for reporting or the evaluation of certain *Prohibited Substances*.

2.2 Use or Attempted Use by an Athlete of a Prohibited Substance or a Prohibited Method⁴

² [Comment to Article 2.1.1: An anti-doping rule violation is committed under this Article without regard to an Athlete's Fault. This rule has been referred to in various CAS decisions as "Strict Liability". An Athlete's Fault is taken into consideration in determining the Consequences of this anti-doping rule violation under Article 10. This principle has consistently been upheld by CAS.]

³ [Comment to Article 2.1.2: The Anti-Doping Organization with Results Management responsibility may, at its discretion, choose to have the B Sample analysed even if the Athlete does not request the analysis of the B Sample.]

⁴ [Comment to Article 2.2: It has always been the case that Use or Attempted Use of a Prohibited Substance or Prohibited Method may be established by any reliable means. As noted in the Comment to Article 3.2, unlike the proof required to establish an anti-doping rule violation under Article 2.1, Use or Attempted Use may also be established by other reliable means such as admissions by the Athlete, witness statements, documentary evidence, conclusions drawn from longitudinal profiling, including data collected as part of the Athlete Biological Passport, or other analytical information which does not otherwise satisfy all the requirements to establish "Presence" of a Prohibited Substance under Article 2.1.

For example, Use may be established based upon reliable analytical data from the analysis of an A Sample (without confirmation from an analysis of a B Sample) or from the analysis of a B Sample alone where the Anti-Doping Organization provides a satisfactory explanation for the lack of confirmation in the other Sample.]

- 2.2.1** It is the *Athletes'* personal duty to ensure that no *Prohibited Substance* enters their bodies and that no *Prohibited Method* is *Used*. Accordingly, it is not necessary that intent, *Fault*, *Negligence* or knowing *Use* on the *Athlete's* part be demonstrated in order to establish an anti-doping rule violation for *Use* of a *Prohibited Substance* or a *Prohibited Method*.
- 2.2.2** The success or failure of the *Use* or *Attempted Use* of a *Prohibited Substance* or *Prohibited Method* is not material. It is sufficient that the *Prohibited Substance* or *Prohibited Method* was *Used* or *Attempted* to be *Used* for an anti-doping rule violation to be committed.⁵

2.3 Evading, Refusing or Failing to Submit to Sample Collection by an Athlete

Evading *Sample* collection; or refusing or failing to submit to *Sample* collection without compelling justification after notification by a duly authorized *Person*.⁶

2.4 Whereabouts Failures by an Athlete

Any combination of three (3) missed tests and/or filing failures, as defined in the *International Standard for Results Management*, within a twelve (12) month period by an *Athlete* in a *Registered Testing Pool*.

2.5 Tampering or Attempted Tampering with any Part of Doping Control by an Athlete or Other Person

2.6 Possession of a Prohibited Substance or a Prohibited Method by an Athlete or Athlete Support Person

- 2.6.1** *Possession* by an *Athlete In-Competition* of any *Prohibited Substance* or any *Prohibited Method*, or *Possession* by an *Athlete Out-of-Competition* of any *Prohibited Substance* or any *Prohibited Method* which is prohibited *Out-of-Competition* unless the *Athlete* establishes that the *Possession* is consistent with a *Therapeutic Use Exemption* ("TUE") granted in accordance with Article 4.4 or other acceptable justification.
- 2.6.2** *Possession* by an *Athlete Support Person In-Competition* of any *Prohibited Substance* or any *Prohibited Method*, or *Possession* by an *Athlete Support Person Out-of-Competition* of any *Prohibited Substance* or any *Prohibited Method* which is prohibited *Out-of-Competition* in connection with an *Athlete*, *Competition* or training, unless the *Athlete Support Person* establishes that the *Possession* is consistent with a *TUE* granted to an *Athlete* in accordance with Article 4.4 or other acceptable justification.⁷

2.7 Trafficking or Attempted Trafficking in any Prohibited Substance or Prohibited Method by an Athlete or Other Person

⁵ [Comment to Article 2.2.2: Demonstrating the "Attempted Use" of a *Prohibited Substance* or a *Prohibited Method* requires proof of intent on the *Athlete's* part. The fact that intent may be required to prove this particular anti-doping rule violation does not undermine the *Strict Liability* principle established for violations of Article 2.1 and violations of Article 2.2 in respect of *Use* of a *Prohibited Substance* or *Prohibited Method*.

An *Athlete's Use* of a *Prohibited Substance* constitutes an anti-doping rule violation unless such substance is not prohibited *Out-of-Competition* and the *Athlete's Use* takes place *Out-of-Competition*. (However, the presence of a *Prohibited Substance* or its *Metabolites* or *Markers* in a *Sample* collected *In-Competition* is a violation of Article 2.1 regardless of when that substance might have been administered.)]

⁶ [Comment to Article 2.3: For example, it would be an anti-doping rule violation of "evading *Sample* collection" if it were established that an *Athlete* was deliberately avoiding a *Doping Control* official to evade notification or *Testing*. A violation of "failing to submit to *Sample* collection" may be based on either intentional or negligent conduct of the *Athlete*, while "evading" or "refusing" *Sample* collection contemplates intentional conduct by the *Athlete*.]

⁷ [Comment to Articles 2.6.1 and 2.6.2: Acceptable justification would not include, for example, buying or Possessing a *Prohibited Substance* for purposes of giving it to a friend or relative, except under justifiable medical circumstances where that *Person* had a physician's prescription, e.g., buying *Insulin* for a diabetic child.]

[Comment to Article 2.6.1 and 2.6.2: Acceptable justification may include, for example, (a) an *Athlete* or a team doctor carrying *Prohibited Substances* or *Prohibited Methods* for dealing with acute and emergency situations (e.g., an *epinephrine auto-injector*), or (b) an *Athlete* Possessing a *Prohibited Substance* or *Prohibited Method* for therapeutic reasons shortly prior to applying for and receiving a determination on a *TUE*.]

2.8 Administration or Attempted Administration by an Athlete or Other Person to any Athlete In-Competition of any Prohibited Substance or Prohibited Method, or Administration or Attempted Administration to any Athlete Out-of-Competition of any Prohibited Substance or any Prohibited Method that is Prohibited Out-of-Competition

2.9 Complicity or Attempted Complicity by an Athlete or Other Person

Assisting, encouraging, aiding, abetting, conspiring, covering up or any other type of intentional complicity or *Attempted* complicity involving an anti-doping rule violation, *Attempted* anti-doping rule violation or violation of Article 10.14.1 by another *Person*.⁸

2.10 Prohibited Association by an Athlete or Other Person

2.10.1 Association by an *Athlete* or other *Person* subject to the authority of an *Anti-Doping Organization* in a professional or sport-related capacity with any *Athlete Support Person* who:

2.10.1.1 If subject to the authority of an *Anti-Doping Organization*, is serving a period of *Ineligibility*, or

2.10.1.2 If not subject to the authority of an *Anti-Doping Organization* and where *Ineligibility* has not been addressed in a *Results Management* process pursuant to the *Code*, has been convicted or found in a criminal, disciplinary or professional proceeding to have engaged in conduct which would have constituted a violation of anti-doping rules if *Code*-compliant rules had been applicable to such *Person*. The disqualifying status of such *Person* shall be in force for the longer of six (6) years from the criminal, professional or disciplinary decision or the duration of the criminal, disciplinary or professional sanction imposed; or

2.10.1.3 Is serving as a front or intermediary for an individual described in Article 2.10.1.1 or 2.10.1.2.

2.10.2 To establish a violation of Article 2.10, an *Anti-Doping Organization* must establish that the *Athlete* or other *Person* knew of the *Athlete Support Person*'s disqualifying status.

The burden shall be on the *Athlete* or other *Person* to establish that any association with an *Athlete Support Person* described in Article 2.10.1.1 or 2.10.1.2 is not in a professional or sport-related capacity and/or that such association could not have been reasonably avoided.

Anti-Doping Organizations that are aware of *Athlete Support Personnel* who meet the criteria described in Article 2.10.1.1, 2.10.1.2, or 2.10.1.3 shall submit that information to WADA.⁹

2.11 Acts by an Athlete or Other Person to Discourage or Retaliate Against Reporting to Authorities

Where such conduct does not otherwise constitute a violation of Article 2.5:

2.11.1 Any act which threatens or seeks to intimidate another *Person* with the intent of discouraging the *Person* from the good-faith reporting of information that relates to an alleged anti-doping rule violation or alleged non-compliance with the *Code* to WADA, an

⁸ [Comment to Article 2.9: Complicity or Attempted Complicity may include either physical or psychological assistance.]

⁹ [Comment to Article 2.10: Athletes and other Persons must not work with coaches, trainers, physicians or other Athlete Support Personnel who are Ineligible on account of an anti-doping rule violation or who have been criminally convicted or professionally disciplined in relation to doping. This also prohibits association with any other Athlete who is acting as a coach or Athlete Support Person while serving a period of Ineligibility. Some examples of the types of association which are prohibited include: obtaining training, strategy, technique, nutrition or medical advice; obtaining therapy, treatment or prescriptions; providing any bodily products for analysis; or allowing the Athlete Support Person to serve as an agent or representative. Prohibited association need not involve any form of compensation.]

While Article 2.10 does not require the *Anti-Doping Organization* to notify the *Athlete* or other *Person* about the *Athlete Support Person*'s disqualifying status, such notice, if provided, would be important evidence to establish that the *Athlete* or other *Person* knew about the disqualifying status of the *Athlete Support Person*.]

Anti-Doping Organization, law enforcement, regulatory or professional disciplinary body, hearing body or *Person* conducting an investigation for *WADA* or an *Anti-Doping Organization*.

- 2.11.2** Retaliation against a *Person* who, in good faith, has provided evidence or information that relates to an alleged anti-doping rule violation or alleged non-compliance with the *Code to WADA*, an *Anti-Doping Organization*, law enforcement, regulatory or professional disciplinary body, hearing body or *Person* conducting an investigation for *WADA* or an *Anti-Doping Organization*.

For purposes of Article 2.11, retaliation, threatening and intimidation include an act taken against such *Person* either because the act lacks a good faith basis or is a disproportionate response.¹⁰

ARTICLE 3 PROOF OF DOPING

3.1 Burdens and Standards of Proof

The UIM shall have the burden of establishing that an anti-doping rule violation has occurred. The standard of proof shall be whether the UIM has established an anti-doping rule violation to the comfortable satisfaction of the hearing panel bearing in mind the seriousness of the allegation which is made. This standard of proof in all cases is greater than a mere balance of probability but less than proof beyond a reasonable doubt. Where these Anti-Doping Rules place the burden of proof upon the *Athlete* or other *Person* alleged to have committed an anti-doping rule violation to rebut a presumption or establish specified facts or circumstances, except as provided in Articles 3.2.2 and 3.2.3, the standard of proof shall be by a balance of probability.¹¹

3.2 Methods of Establishing Facts and Presumptions

Facts related to anti-doping rule violations may be established by any reliable means, including admissions.¹² The following rules of proof shall be applicable in doping cases:

- 3.2.1** Analytical methods or *Decision Limits* approved by *WADA* after consultation within the relevant scientific community or which have been the subject of peer review are presumed to be scientifically valid. Any *Athlete* or other *Person* seeking to challenge whether the conditions for such presumption have been met or to rebut this presumption of scientific validity shall, as a condition precedent to any such challenge, first notify *WADA* of the challenge and the basis of the challenge. The initial hearing body, appellate body or *CAS*, on its own initiative, may also inform *WADA* of any such challenge. Within ten (10) days of *WADA*'s receipt of such notice and the case file related to such challenge, *WADA* shall also have the right to intervene as a party, appear as amicus curiae or otherwise provide evidence in such proceeding. In cases before *CAS*, at

¹⁰ [Comment to Article 2.11.2: This Article is intended to protect Persons who make good faith reports, and does not protect Persons who knowingly make false reports.]

[Comment to Article 2.11.2: Retaliation would include, for example, actions that threaten the physical or mental well-being or economic interests of the reporting Persons, their families or associates. Retaliation would not include an Anti-Doping Organization asserting in good faith an anti-doping rule violation against the reporting Person. For purposes of Article 2.11, a report is not made in good faith where the Person making the report knows the report to be false.]

¹¹ Comment to Article 3.1: This standard of proof required to be met by the UIM is comparable to the standard which is applied in most countries to cases involving professional misconduct.]

¹² [Comment to Article 3.2: For example, the UIM may establish an anti-doping rule violation under Article 2.2 based on the Athlete's admissions, the credible testimony of third Persons, reliable documentary evidence, reliable analytical data from either an A or B Sample as provided in the Comments to Article 2.2, or conclusions drawn from the profile of a series of the Athlete's blood or urine Samples, such as data from the Athlete Biological Passport.]

[

WADA's request, the CAS panel shall appoint an appropriate scientific expert to assist the panel in its evaluation of the challenge.¹³

- 3.2.2** WADA-accredited laboratories, and other laboratories approved by WADA, are presumed to have conducted *Sample* analysis and custodial procedures in accordance with the *International Standard* for Laboratories. The *Athlete* or other *Person* may rebut this presumption by establishing that a departure from the *International Standard* for Laboratories occurred which could reasonably have caused the *Adverse Analytical Finding*.

If the *Athlete* or other *Person* rebuts the preceding presumption by showing that a departure from the *International Standard* for Laboratories occurred which could reasonably have caused the *Adverse Analytical Finding*, then the UIM shall have the burden to establish that such departure did not cause the *Adverse Analytical Finding*.¹⁴

- 3.2.3** Departures from any other *International Standard* or other anti-doping rule or policy set forth in the *Code* or these Anti-Doping Rules shall not invalidate analytical results or other evidence of an anti-doping rule violation, and shall not constitute a defense to an anti-doping rule violation;¹⁵ provided, however, if the *Athlete* or other *Person* establishes that a departure from one of the specific *International Standard* provisions listed below could reasonably have caused an anti-doping rule violation based on an *Adverse Analytical Finding* or whereabouts failure, then the UIM shall have the burden to establish that such departure did not cause the *Adverse Analytical Finding* or the whereabouts failure:

- (i) a departure from the *International Standard* for *Testing* and *Investigations* related to *Sample* collection or *Sample* handling which could reasonably have caused an anti-doping rule violation based on an *Adverse Analytical Finding*, in which case the UIM shall have the burden to establish that such departure did not cause the *Adverse Analytical Finding*;
- (ii) a departure from the *International Standard* for *Results Management* or *International Standard* for *Testing* and *Investigations* related to an *Adverse Passport Finding* which could reasonably have caused an anti-doping rule violation, in which case the UIM shall have the burden to establish that such departure did not cause the anti-doping rule violation;
- (iii) a departure from the *International Standard* for *Results Management* related to the requirement to provide notice to the *Athlete* of the B *Sample* opening which could reasonably have caused an anti-doping rule violation based on an *Adverse Analytical Finding*, in which case the UIM shall have the burden

¹³ [Comment to Article 3.2.1: For certain Prohibited Substances, WADA may instruct WADA-accredited laboratories not to report Samples as an Adverse Analytical Finding if the estimated concentration of the Prohibited Substance or its Metabolites or Markers is below a Minimum Reporting Level. WADA's decision in determining that Minimum Reporting Level or in determining which Prohibited Substances should be subject to Minimum Reporting Levels shall not be subject to challenge. Further, the laboratory's estimated concentration of such Prohibited Substance in a Sample may only be an estimate. In no event shall the possibility that the exact concentration of the Prohibited Substance in the Sample may be below the Minimum Reporting Level constitute a defense to an anti-doping rule violation based on the presence of that Prohibited Substance in the Sample.]

¹⁴ [Comment to Article 3.2.2: The burden is on the Athlete or other Person to establish, by a balance of probability, a departure from the International Standard for Laboratories that could reasonably have caused the Adverse Analytical Finding. Thus, once the Athlete or other Person establishes the departure by a balance of probability, the Athlete or other Person's burden on causation is the somewhat lower standard of proof – "could reasonably have caused." If the Athlete or other Person satisfies these standards, the burden shifts to the UIM to prove to the comfortable satisfaction of the hearing panel that the departure did not cause the Adverse Analytical Finding.]

¹⁵ [Comment to Article 3.2.3: Departures from an International Standard or other rule unrelated to Sample collection or handling, Adverse Passport Finding, or Athlete notification relating to whereabouts failure or B Sample opening – e.g., the International Standards for Education, International Standard for the Protection of Privacy and Personal Information or International Standard for Therapeutic Use Exemptions – may result in compliance proceedings by WADA but are not a defense in an anti-doping rule violation proceeding and are not relevant on the issue of whether the Athlete committed an anti-doping rule violation. Similarly, the UIM's violation of the document referenced in Article 20.7.7 of the Code shall not constitute a defense to an anti-doping rule violation.]

to establish that such departure did not cause the *Adverse Analytical Finding*.¹⁶

- (iv) a departure from the *International Standard for Results Management* related to *Athlete* notification which could reasonably have caused an anti-doping rule violation based on a whereabouts failure, in which case the UIM shall have the burden to establish that such departure did not cause the whereabouts failure.

3.2.4 The facts established by a decision of a court or professional disciplinary tribunal of competent jurisdiction which is not the subject of a pending appeal shall be irrebuttable evidence against the *Athlete* or other *Person* to whom the decision pertained of those facts unless the *Athlete* or other *Person* establishes that the decision violated principles of natural justice.

3.2.5 The hearing panel in a hearing on an anti-doping rule violation may draw an inference adverse to the *Athlete* or other *Person* who is asserted to have committed an anti-doping rule violation based on the *Athlete's* or other *Person's* refusal, after a request made in a reasonable time in advance of the hearing, to appear at the hearing (either in person or telephonically as directed by the hearing panel) and to answer questions from the hearing panel or the UIM.

ARTICLE 4 THE *PROHIBITED LIST*

4.1 Incorporation of the *Prohibited List*

These Anti-Doping Rules incorporate the *Prohibited List*, which is published and revised by WADA as described in Article 4.1 of the *Code*.

Unless provided otherwise in the *Prohibited List* or a revision, the *Prohibited List* and revisions shall go into effect under these Anti-Doping Rules three (3) months after publication by WADA, without requiring any further action by the UIM or its *National Authorities*. All *Athletes* and other *Persons* shall be bound by the *Prohibited List*, and any revisions thereto, from the date they go into effect, without further formality. It is the responsibility of all *Athletes* and other *Persons* to familiarize themselves with the most up-to-date version of the *Prohibited List* and all revisions thereto.

The UIM shall provide its *National Authorities* with the most recent version of the *Prohibited List*. Each *National Authority* shall in turn ensure that its members, and the constituents of its members, are also provided with the most recent version of the *Prohibited List*.¹⁷

4.2 Prohibited Substances and Prohibited Methods Identified on the Prohibited List

4.2.1 *Prohibited Substances and Prohibited Methods*

The *Prohibited List* shall identify those *Prohibited Substances* and *Prohibited Methods* which are prohibited as doping at all times (both *In-Competition* and *Out-of-Competition*) because of their potential to enhance performance in future *Competitions* or their masking potential, and those substances and methods which are prohibited *In-Competition* only. The *Prohibited List* may be expanded by WADA for a particular sport. *Prohibited Substances* and *Prohibited Methods* may be included in the *Prohibited List* by general category (e.g., anabolic agents) or by specific reference to a particular substance or method.¹⁸

¹⁶ [Comment to Article 3.2.3 (iii): the UIM would meet its burden to establish that such departure did not cause the *Adverse Analytical Finding* by showing that, for example, the B Sample opening and analysis were observed by an independent witness and no irregularities were observed.]

¹⁷ [Comment to Article 4.1: The current *Prohibited List* is available on WADA's website at <https://www.wada-ama.org>. The *Prohibited List* will be revised and published on an expedited basis whenever the need arises. However, for the sake of predictability, a new *Prohibited List* will be published every year whether or not changes have been made.]

¹⁸ [Comment to Article 4.2.1: *Out-of-Competition Use of a substance which is only prohibited In-Competition is not an anti-doping rule violation unless an Adverse Analytical Finding for the substance or its Metabolites or Markers is reported for a Sample collected In-Competition.*]

4.2.2 Specified Substances or Specified Methods

For purposes of the application of Article 10, all *Prohibited Substances* shall be *Specified Substances* except as identified on the *Prohibited List*. No *Prohibited Method* shall be a *Specified Method* unless it is specifically identified as a *Specified Method* on the *Prohibited List*.¹⁹

4.2.3 Substances of Abuse

For purposes of applying Article 10, *Substances of Abuse* shall include those *Prohibited Substances* which are specifically identified as *Substances of Abuse* on the *Prohibited List* because they are frequently abused in society outside of the context of sport.

4.3 WADA's Determination of the *Prohibited List*

WADA's determination of the *Prohibited Substances* and *Prohibited Methods* that will be included on the *Prohibited List*, the classification of substances into categories on the *Prohibited List*, the classification of a substance as prohibited at all times or *In-Competition* only, the classification of a substance or method as a *Specified Substance*, *Specified Method* or *Substance of Abuse* is final and shall not be subject to any challenge by an *Athlete* or other *Person* including, but not limited to, any challenge based on an argument that the substance or method was not a masking agent or did not have the potential to enhance performance, represent a health risk or violate the spirit of sport.

4.4 Therapeutic Use Exemptions ("TUEs")

4.4.1 The presence of a *Prohibited Substance* or its *Metabolites* or *Markers*, and/or the *Use* or *Attempted Use*, *Possession* or *Administration* or *Attempted Administration* of a *Prohibited Substance* or *Prohibited Method*, shall not be considered an anti-doping rule violation if it is consistent with the provisions of a *TUE* granted in accordance with the *International Standard for Therapeutic Use Exemptions*.

4.4.2 TUE Applications

4.4.2.1 *Athletes* who are not *International-Level Athletes* shall apply to their *National Anti-Doping Organization* for a *TUE*. If the *National Anti-Doping Organization* denies the application, the *Athlete* may appeal exclusively to the national-level appeal body described in Article 13.2.2.

4.4.2.2 *Athletes* who are *International-Level Athletes* shall apply to the UIM.

4.4.3 TUE Recognition²⁰

4.4.3.1 Where the *Athlete* already has a *TUE* granted by their *National Anti-Doping Organization* pursuant to Article 4.4 of the *Code* for the substance or method in question and provided that such *TUE* has been reported in accordance with Article 5.5 of the *International Standard for Therapeutic Use Exemptions*, the UIM will automatically recognize it for purposes of international-level *Competition* without the need to review the relevant clinical information.

4.4.3.2 If the UIM chooses to test an *Athlete* who is not an *International-Level Athlete*, the UIM must recognize a *TUE* granted to that *Athlete* by their *National Anti-Doping Organization* unless the *Athlete* is required to apply for recognition of

¹⁹ [Comment to Article 4.2.2: The *Specified Substances* and *Methods* identified in Article 4.2.2 should not in any way be considered less important or less dangerous than other doping substances or methods. Rather, they are simply substances and methods which are more likely to have been consumed or used by an *Athlete* for a purpose other than the enhancement of sport performance.]

²⁰ [Comment to Article 4.4.3: If the UIM refuses to recognize a *TUE* granted by a *National Anti-Doping Organization* only because medical records or other information are missing that are needed to demonstrate satisfaction with the criteria in the *International Standard for Therapeutic Use Exemptions*, the matter should not be referred to WADA. Instead, the file should be completed and re-submitted to the UIM.]

[Comment to Article 4.4.3: the UIM may agree with a *National Anti-Doping Organization* that the *National Anti-Doping Organization* will consider *TUE* applications on behalf of the UIM.]

the *TUE* pursuant to Articles 5.8 and 7.0 of the *International Standard for Therapeutic Use Exemptions*.

4.4.4 *TUE* Application Process ²¹

- 4.4.4.1** If the *Athlete* does not already have a *TUE* granted by their *National Anti-Doping Organization* for the substance or method in question, the *Athlete* must apply directly to the UIM.
- 4.4.4.2** An application to the UIM for grant or recognition of a *TUE* must be made as soon as possible, save where Articles 4.1 or 4.3 of the *International Standard for Therapeutic Use Exemptions* apply. The application shall be made in accordance with Article 6 of the *International Standard for Therapeutic Use Exemptions* as posted on the UIM's website.
- 4.4.4.3** The UIM shall establish a *Therapeutic Use Exemption Committee* ("TUEC") to consider applications for the grant or recognition of *TUEs*.. in accordance with Article 4.4.4.3(a)-(d) below:
- (a) The TUEC shall consist of a minimum of five (5) members with experience in the care and treatment of *Athletes* and sound knowledge of clinical, sports and exercise medicine. Each appointed member should serve a term of four (4) years which is renewable.
 - (b) Before serving as a member of the TUEC, each member must sign a conflict of interest and confidentiality declaration. The appointed members shall not be employees of [IF]the UIM.
 - (c) When an application to [IF]the UIM for the grant or recognition of a *TUE* is made, the Chair of the TUEC or the [IF]the UIM shall appoint three (3) members (which may include the Chair) to consider the application.
 - (d) Before considering a *TUE* application, each member shall disclose any circumstances likely to affect their impartiality with respect to the *Athlete* making the application. If a member is unwilling or unable to assess the *Athlete's TUE* application, for any reason, the Chair or the [IF]the UIM shall appoint a replacement from the pool of members appointed under point (a) above. The Chair cannot serve as a member of the TUEC if there are any circumstances which are likely to affect the impartiality of the *TUE* decision.
- 4.4.4.4** The TUEC shall promptly evaluate and decide upon the application in accordance with the relevant provisions of the *International Standard for Therapeutic Use Exemptions* and usually (i.e., unless exceptional circumstances apply) within no more than twenty-one (21) days of receipt of a complete application. Where the application is made in a reasonable time prior to an *Event*, the TUEC must use its best endeavors to issue its decision before the start of the *Event*.
- 4.4.4.5** The TUEC decision shall be the final decision of the UIM and may be appealed in accordance with Article 4.4.7. the UIM TUEC decision shall be notified in writing to the *Athlete*, and to *WADA* and other *Anti-Doping Organizations* in accordance with the *International Standard for Therapeutic Use Exemptions*. It shall also promptly be reported into *ADAMS*.
- 4.4.4.6** If the UIM (or the *National Anti-Doping Organization*, where it has agreed to consider the application on behalf of the UIM) denies the *Athlete's* application,

²¹ [Comment to Article 4.4.4: The submission of falsified documents to a TUEC or the UIM, offering or accepting a bribe to a Person to perform or fail to perform an act, procuring false testimony from any witness, or committing any other fraudulent act or any other similar intentional interference or Attempted interference with any aspect of the *TUE* process shall result in a charge of *Tampering* or *Attempted Tampering* under Article 2.5.

An *Athlete* should not assume that their application for the grant or recognition of a *TUE* (or for renewal of a *TUE*) will be granted. Any Use or Possession or Administration of a Prohibited Substance or Prohibited Method before an application has been granted is entirely at the *Athlete's* own risk.]

it must notify the *Athlete* promptly, with reasons. If the UIM grants the *Athlete's* application, it must notify not only the *Athlete* but also their *National Anti-Doping Organization*. If the *National Anti-Doping Organization* considers that the *TUE* granted by the UIM does not meet the criteria set out in the *International Standard for Therapeutic Use Exemptions*, it has twenty-one (21) days from such notification to refer the matter to WADA for review in accordance with Article 4.4.7.

If the *National Anti-Doping Organization* refers the matter to WADA for review, the *TUE* granted by the UIM remains valid for international-level *Competition* and *Out-of-Competition Testing* (but is not valid for national-level *Competition*) pending WADA's decision. If the *National Anti-Doping Organization* does not refer the matter to WADA for review, the *TUE* granted by the UIM becomes valid for national-level *Competition* as well when the twenty-one (21) day review deadline expires.

4.4.5 Retroactive *TUE* Applications

If the UIM chooses to collect a *Sample* from an *Athlete* who is not an *International-Level Athlete* or a *National-Level Athlete*, and that *Athlete* is *Using a Prohibited Substance* or *Prohibited Method* for therapeutic reasons, the UIM must permit that *Athlete* to apply for a retroactive *TUE*.

4.4.6 Expiration, Withdrawal or Reversal of a *TUE*

4.4.6.1 A *TUE* granted pursuant to these Anti-Doping Rules: (a) shall expire automatically at the end of any term for which it was granted, without the need for any further notice or other formality; (b) will be withdrawn if the *Athlete* does not promptly comply with any requirements or conditions imposed by the TUEC upon grant of the *TUE*; (c) may be withdrawn by the TUEC if it is subsequently determined that the criteria for grant of a *TUE* are not in fact met; or (d) may be reversed on review by WADA or on appeal.

4.4.6.2 In such event, the *Athlete* shall not be subject to any *Consequences* based on their *Use* or *Possession* or *Administration* of the *Prohibited Substance* or *Prohibited Method* in question in accordance with the *TUE* prior to the effective date of expiry, withdrawal, or reversal of the *TUE*. The review pursuant to Article 5.1.1.1 of the *International Standard for Results Management* of an *Adverse Analytical Finding*, reported shortly after the *TUE* expiry, withdrawal or reversal, shall include consideration of whether such finding is consistent with *Use* of the *Prohibited Substance* or *Prohibited Method* prior to that date, in which event no anti-doping rule violation shall be asserted.

4.4.7 Reviews and Appeals of *TUE* Decisions

4.4.7.1 WADA must review the UIM's decision not to recognize a *TUE* granted by the *National Anti-Doping Organization* that is referred to WADA by the *Athlete* or the *Athlete's National Anti-Doping Organization*. In addition, WADA must review the UIM's decision to grant a *TUE* that is referred to WADA by the *Athlete's National Anti-Doping Organization*. WADA may review any other *TUE* decisions at any time, whether upon request by those affected or on its own initiative. If the *TUE* decision being reviewed meets the criteria set out in the *International Standard for Therapeutic Use Exemptions*, WADA will not interfere with it. If the *TUE* decision does not meet those criteria, WADA will reverse it.²²

4.4.7.2 Any *TUE* decision by the UIM (or by a *National Anti-Doping Organization* where it has agreed to consider the application on behalf of the UIM) that is not reviewed by WADA, or that is reviewed by WADA but is not reversed upon

²² [Comment to Article 4.4.7.1: WADA shall be entitled to charge a fee to cover the costs of: (a) any review it is required to conduct in accordance with Article 4.4.7; and (b) any review it chooses to conduct, where the decision being reviewed is reversed.]

review, may be appealed by the *Athlete* and/or the *Athlete's National Anti-Doping Organization*, exclusively to CAS.²³

4.4.7.3 A decision by WADA to reverse a *TUE* decision may be appealed by the *Athlete*, the *National Anti-Doping Organization* and/or the UIM, exclusively to CAS.

4.4.7.4 A failure to render a decision within a reasonable time on a properly submitted application for grant/recognition of a *TUE* or for review of a *TUE* decision shall be considered a denial of the application thus triggering the applicable rights of review/appeal.

ARTICLE 5 TESTING AND INVESTIGATIONS

5.1 Purpose of *Testing* and Investigations²⁴

5.1.1 *Testing* and investigations may be undertaken for any anti-doping purpose. They shall be conducted in conformity with the provisions of the *International Standard for Testing and Investigations*.

5.1.2 *Testing* shall be undertaken to obtain analytical evidence as to whether the *Athlete* has violated Article 2.1 (Presence of a *Prohibited Substance* or its *Metabolites* or *Markers* in an *Athlete's Sample*) or Article 2.2 (*Use or Attempted Use* by an *Athlete* of a *Prohibited Substance* or a *Prohibited Method*).

5.2 Authority to Test

5.2.1 Subject to the limitations for *Event Testing* set out in Article 5.3, the UIM shall have *In-Competition* and *Out-of-Competition Testing* authority over all *Athletes* specified in the Introduction to these Anti-Doping Rules (Section "Scope of these Anti-Doping Rules").

5.2.2 The UIM may require any *Athlete* over whom it has *Testing* authority (including any *Athlete* serving a period of *Ineligibility*) to provide a *Sample* at any time and at any place.²⁵

5.2.3 WADA shall have *In-Competition* and *Out-of-Competition Testing* authority as set out in Article 20.7.10 of the *Code*.

5.2.4 If the UIM delegates or contracts any part of *Testing* to a *National Anti-Doping Organization* directly or through a *National Authority*, that *National Anti-Doping Organization* may collect additional *Samples* or direct the laboratory to perform additional types of analysis at the *National Anti-Doping Organization's* expense. If additional *Samples* are collected or additional types of analysis are performed, the UIM shall be notified.

5.3 Event Testing

5.3.1 Except as otherwise provided below, only a single organization shall have authority to conduct *Testing* at *Event Venues* during an *Event Period*. At *International Events*, the UIM (or other international organization which is the ruling body for an *Event*) shall have

²³ [Comment to Article 4.4.7.2: In such cases, the decision being appealed is the UIM's *TUE* decision, not WADA's decision not to review the *TUE* decision or (having reviewed it) not to reverse the *TUE* decision. However, the time to appeal the *TUE* decision does not begin to run until the date that WADA communicates its decision. In any event, whether the decision has been reviewed by WADA or not, WADA shall be given notice of the appeal so that it may participate if it sees fit.]

²⁴ [Comment to Article 5.1: Where *Testing* is conducted for anti-doping purposes, the analytical results and data may be used for other legitimate purposes under the *Anti-Doping Organization's* rules. See, e.g., Comment to Article 23.2.2 of the *Code*.]

²⁵ [Comment to Article 5.2.2: the UIM may obtain additional authority to conduct *Testing* by means of bilateral or multilateral agreements with other Signatories. Unless the *Athlete* has identified a sixty (60) minute *Testing* window between the hours of 11:00 p.m. and 6:00 a.m., or has otherwise consented to *Testing* during that period, the UIM will not test an *Athlete* during that period unless it has a serious and specific suspicion that the *Athlete* may be engaged in doping. A challenge to whether the UIM had sufficient suspicion for *Testing* during this time period shall not be a defense to an anti-doping rule violation based on such test or attempted test.]

authority to conduct *Testing*. At *National Events*, the *National Anti-Doping Organization* of that country shall have authority to conduct *Testing*. At the request of the UIM (or other international organization which is the ruling body for an *Event*), any *Testing* during the *Event Period* outside of the *Event Venues* shall be coordinated with the UIM (or the relevant ruling body of the *Event*).

- 5.3.2** If an *Anti-Doping Organization*, which would otherwise have *Testing* authority but is not responsible for initiating and directing *Testing* at an *Event*, desires to conduct *Testing* of *Athletes* at the *Event Venues* during the *Event Period*, the *Anti-Doping Organization* shall first confer with the UIM (or other international organization which is the ruling body of the *Event*) to obtain permission to conduct and coordinate such *Testing*. If the *Anti-Doping Organization* is not satisfied with the response from the UIM (or other international organization which is the ruling body of the *Event*), the *Anti-Doping Organization* may, in accordance with the procedures described in the *International Standard for Testing and Investigations*, ask WADA for permission to conduct *Testing* and to determine how to coordinate such *Testing*. WADA shall not grant approval for such *Testing* before consulting with and informing the UIM (or other international organization which is the ruling body for the *Event*). WADA's decision shall be final and not subject to appeal. Unless otherwise provided in the authorization to conduct *Testing*, such tests shall be considered *Out-of-Competition* tests. *Results Management* for any such test shall be the responsibility of the *Anti-Doping Organization* initiating the test unless provided otherwise in the rules of the ruling body of the *Event*.²⁶

5.4 Testing Requirements

- 5.4.1** The UIM shall conduct test distribution planning and *Testing* as required by the *International Standard for Testing and Investigations*.
- 5.4.2** Where reasonably feasible, *Testing* shall be coordinated through ADAMS in order to maximize the effectiveness of the combined *Testing* effort and to avoid unnecessary repetitive *Testing*.

5.5 Athlete Whereabouts Information

- 5.5.1** The UIM may establish a *Registered Testing Pool* of those *Athletes* who are required to provide whereabouts information in the manner specified in the *International Standard for Testing and Investigations* and who shall be subject to *Consequences* for Article 2.4 violations as provided in Article 10.3.2. the UIM shall coordinate with *National Anti-Doping Organizations* to identify such *Athletes* and to collect their whereabouts information.
- 5.5.2** The UIM shall make available through ADAMS a list which identifies those *Athletes* included in its *Registered Testing Pool* by name. the UIM shall regularly review and update as necessary its criteria for including *Athletes* in its *Registered Testing Pool*, and shall periodically (but not less than quarterly) review the list of *Athletes* in its *Registered Testing Pool* to ensure that each listed *Athlete* continues to meet the relevant criteria. *Athletes* shall be notified before they are included in the *Registered Testing Pool* and when they are removed from that pool. The notification shall contain the information set out in the *International Standard for Testing and Investigations*.
- 5.5.3** Where an *Athlete* is included in an international *Registered Testing Pool* by the UIM and in a national *Registered Testing Pool* by their *National Anti-Doping Organization*, the *National Anti-Doping Organization* and the UIM shall agree between themselves which of them shall accept that *Athlete's* whereabouts filings; in no case shall an *Athlete* be required to make whereabouts filings to more than one of them.
- 5.5.4** In accordance with the *International Standard for Testing and Investigations*, each *Athlete* in the *Registered Testing Pool* shall do the following: (a) advise the UIM of his/her

²⁶ [Comment to Article 5.3.2: Before giving approval to a National Anti-Doping Organization to initiate and conduct Testing at an International Event, WADA shall consult with the international organization which is the ruling body for the Event. Before giving approval to an International Federation to initiate and conduct Testing at a National Event, WADA shall consult with the National Anti-Doping Organization of the country where the Event takes place. The Anti-Doping Organization "initiating and directing Testing" may, if it chooses, enter into agreements with a Delegated Third Party to which it delegates responsibility for Sample collection or other aspects of the Doping Control process.]

whereabouts on a quarterly basis; (b) update that information as necessary so that it remains accurate and complete at all times; and (c) make himself or herself available for *Testing* at such whereabouts.

- 5.5.5** For purposes of Article 2.4, an *Athlete's* failure to comply with the requirements of the *International Standard for Testing and Investigations* shall be deemed a filing failure or a missed test, as defined in Annex B of the *International Standard for Results Management*, where the conditions set forth in Annex B are met.
- 5.5.6** An *Athlete* in the UIM's *Registered Testing Pool* shall continue to be subject to the obligation to comply with the whereabouts requirements set in the *International Standard for Testing and Investigations* unless and until (a) the *Athlete* gives written notice to the UIM that he or she has retired or (b) the UIM has informed him or her that he or she no longer satisfies the criteria for inclusion in the UIM's *Registered Testing Pool*.
- 5.5.7** Whereabouts information provided by an *Athlete* while in the *Registered Testing Pool* will be accessible through ADAMS to WADA and to other *Anti-Doping Organizations* having authority to test that *Athlete* as provided in Article 5.2. Whereabouts information shall be maintained in strict confidence at all times; it shall be used exclusively for purposes of planning, coordinating or conducting *Doping Control*, providing information relevant to the *Athlete Biological Passport* or other analytical results, to support an investigation into a potential anti-doping rule violation, or to support proceedings alleging an anti-doping rule violation; and shall be destroyed after it is no longer relevant for these purposes in accordance with the *International Standard for the Protection of Privacy and Personal Information*.
- 5.5.8** The UIM may, in accordance with the *International Standard for Testing and Investigations*, collect whereabouts information from *Athletes* who are not included within a *Registered Testing Pool*. If it chooses to do so, an *Athlete's* failure to provide requested whereabouts information on or before the date required by the UIM or the *Athlete's* failure to provide accurate whereabouts information may result in consequences defined in Article 5.5.12 below (if one established).
- 5.5.9** In accordance with the *International Standard for Testing and Investigations*, the UIM may establish a *Testing Pool*, which includes *Athletes* who are subject to less stringent whereabouts requirements than *Athletes* included in the UIM's *Registered Testing Pool*.
- 5.5.10** The UIM shall notify *Athletes* before they are included in the *Testing Pool* and when they are removed. Such notification shall include the whereabouts requirements and the consequences that apply in case of non-compliance, as indicated in Articles 5.5.11 and 5.5.12.
- 5.5.11** *Athletes* included in the *Testing Pool* shall provide the UIM at least with the following whereabouts information so that they may be located and subjected to *Testing*:
- (a) An overnight address;
 - (b) Competition / Event schedule; and
 - (c) Regular training activities.
- Such whereabouts information shall be filed in ADAMS to enable better *Testing* coordination with other *Anti-Doping Organizations*.
- 5.5.12** An *Athlete's* failure to provide whereabouts information on or before the date required by the UIM or the *Athlete's* failure to provide accurate whereabouts information may result in the UIM elevating the *Athlete* to the UIM's *Registered Testing Pool* (if one established) and additional appropriate and proportionate non-Code Article 2.4 consequences, established by the UIM if any.

5.6 Retired *Athletes* Returning to *Competition*

- 5.6.1** If an *International-Level Athlete* or *National-Level Athlete* in the UIM's *Registered Testing Pool* retires and then wishes to return to active participation in sport, the *Athlete* shall not compete in *International Events* or *National Events* until the *Athlete* has made himself or

herself available for *Testing*, by giving six (6) months prior written notice to the UIM and their *National Anti-Doping Organization*.

WADA, in consultation with the UIM and the *Athlete's National Anti-Doping Organization*, may grant an exemption to the six (6) month written notice rule where the strict application of that rule would be unfair to the *Athlete*. This decision may be appealed under Article 13.²⁷

Any competitive results obtained in violation of this Article 5.6.1 shall be *Disqualified* unless the *Athlete* can establish that he or she could not have reasonably known that this was an *International Event* or a *National Event*.

- 5.6.2** If an *Athlete* retires from sport while subject to a period of *Ineligibility*, the *Athlete* must notify the *Anti-Doping Organization* that imposed the period of *Ineligibility* in writing of such retirement. If the *Athlete* then wishes to return to active competition in sport, the *Athlete* shall not compete in *International Events* or *National Events* until the *Athlete* has made himself or herself available for *Testing* by giving six (6) months prior written notice (or notice equivalent to the period of *Ineligibility* remaining as of the date the *Athlete* retired, if that period was longer than six (6) months) to the UIM and to their *National Anti-Doping Organization*.

5.7 Independent Observer Program

The UIM and the organizing committees for the UIM's *Events*, as well as the *National Authorities* and the organizing committees for *National Events*, shall authorize and facilitate the *Independent Observer Program* at *such Events*.

ARTICLE 6 ANALYSIS OF SAMPLES

Samples shall be analysed in accordance with the following principles:

6.1 Use of Accredited, Approved Laboratories and Other Laboratories

- 6.1.1** For purposes of directly establishing an *Adverse Analytical Finding* under Article 2.1, *Samples* shall be analysed only in WADA-accredited laboratories or laboratories otherwise approved by WADA. The choice of the WADA-accredited or WADA-approved laboratory used for the *Sample* analysis shall be determined exclusively by the UIM.²⁸
- 6.1.2** As provided in Article 3.2, facts related to anti-doping rule violations may be established by any reliable means. This would include, for example, reliable laboratory or other forensic testing conducted outside of WADA-accredited or approved laboratories.

6.2 Purpose of Analysis of Samples and Data

Samples and related analytical data or *Doping Control* information shall be analysed to detect *Prohibited Substances* and *Prohibited Methods* identified on the *Prohibited List* and other substances as may be directed by WADA pursuant to the monitoring program described in Article 4.5 of the *Code*, or to assist the UIM in profiling relevant parameters in an *Athlete's* urine, blood or other matrix, including for DNA or genomic profiling, or for any other legitimate anti-doping purpose.²⁹

²⁷ [Comment to Article 5.6.1: WADA has developed a [protocol and exemption application form](#) that Athletes must use to make such requests, and a [decision template](#) that the International Federations must use. Both documents are available on WADA's website at <https://www.wada-ama.org>.]

²⁸ [Comment to Article 6.1: Violations of Article 2.1 may be established only by Sample analysis performed by a WADA-accredited laboratory or another laboratory approved by WADA. Violations of other Articles may be established using analytical results from other laboratories so long as the results are reliable.]

²⁹ [Comment to Article 6.2: For example, relevant Doping Control-related information could be used to direct Target Testing or to support an anti-doping rule violation proceeding under Article 2.2, or both.]

6.3 Research on Samples and Data

Samples, related analytical data and *Doping Control* information may be used for anti-doping research purposes, although no *Sample* may be used for research without the *Athlete's* written consent. *Samples* and related analytical data or *Doping Control* information used for research purposes shall first be processed in such a manner as to prevent *Samples* and related analytical data or *Doping Control* information being traced back to a particular *Athlete*. Any research involving *Samples* and related analytical data or *Doping Control* information shall adhere to the principles set out in Article 19 of the *Code*.³⁰

6.4 Standards for Sample Analysis and Reporting

In accordance with Article 6.4 of the *Code*, the UIM shall ask laboratories to analyse *Samples* in conformity with the *International Standard* for Laboratories and Article 4.7 of the *International Standard* for Testing and Investigations.

Laboratories at their own initiative and expense may analyse *Samples* for *Prohibited Substances* or *Prohibited Methods* not included on the standard *Sample* analysis menu, or as requested by the UIM. Results from any such analysis shall be reported to the UIM and have the same validity and *Consequences* as any other analytical result.³¹

6.5 Further Analysis of a Sample Prior to or During Results Management

There shall be no limitation on the authority of a laboratory to conduct repeat or additional analysis on a *Sample* prior to the time the UIM notifies an *Athlete* that the *Sample* is the basis for an Article 2.1 anti-doping rule violation charge. If after such notification the UIM wishes to conduct additional analysis on that *Sample*, it may do so with the consent of the *Athlete* or approval from a hearing body.

6.6 Further Analysis of a Sample After it has been Reported as Negative or has Otherwise not Resulted in an Anti-Doping Rule Violation Charge

After a laboratory has reported a *Sample* as negative, or the *Sample* has not otherwise resulted in an anti-doping rule violation charge, it may be stored and subjected to further analyses for the purpose of Article 6.2 at any time exclusively at the direction of either the *Anti-Doping Organization* that initiated and directed *Sample* collection or WADA. Any other *Anti-Doping Organization* with authority to test the *Athlete* that wishes to conduct further analysis on a stored *Sample* may do so with the permission of the *Anti-Doping Organization* that initiated and directed *Sample* collection or WADA, and shall be responsible for any follow-up *Results Management*. Any *Sample* storage or further analysis initiated by WADA or another *Anti-Doping Organization* shall be at WADA's or that organization's expense. Further analysis of *Samples* shall conform with the requirements of the *International Standard* for Laboratories.

6.7 Split of A or B Sample

Where WADA, an *Anti-Doping Organization* with *Results Management* authority, and/or a WADA-accredited laboratory (with approval from WADA or the *Anti-Doping Organization* with *Results Management* authority) wishes to split an A or B *Sample* for the purpose of using the first part of the split *Sample* for an A *Sample* analysis and the second part of the split *Sample* for confirmation, then the procedures set forth in the *International Standard* for Laboratories shall be followed.

6.8 WADA's Right to Take Possession of Samples and Data

WADA may, in its sole discretion at any time, with or without prior notice, take physical possession of any *Sample* and related analytical data or information in the possession of a laboratory or *Anti-Doping Organization*. Upon request by WADA, the laboratory or *Anti-Doping Organization* in possession of the

³⁰ [Comment to Article 6.3: As is the case in most medical or scientific contexts, use of *Samples* and related information for quality assurance, quality improvement, method improvement and development or to establish reference populations is not considered research. *Samples* and related information used for such permitted non-research purposes must also first be processed in such a manner as to prevent them from being traced back to the particular *Athlete*, having due regard to the principles set out in Article 19 of the *Code*, as well as the requirements of the *International Standard* for Laboratories and *International Standard* for the Protection of Privacy and Personal Information.]

³¹ [Comment to Article 6.4: The objective of this Article is to extend the principle of "Intelligent Testing" to the *Sample* analysis menu so as to most effectively and efficiently detect doping. It is recognized that the resources available to fight doping are limited and that increasing the *Sample* analysis menu may, in some sports and countries, reduce the number of *Samples* which can be analysed.]

Sample or data shall immediately grant access to and enable WADA to take physical possession of the *Sample* or data. If WADA has not provided prior notice to the laboratory or *Anti-Doping Organization* before taking possession of a *Sample* or data, it shall provide such notice to the laboratory and each *Anti-Doping Organization* whose *Samples* or data have been taken by WADA within a reasonable time after taking possession. After analysis and any investigation of a seized *Sample* or data, WADA may direct another *Anti-Doping Organization* with authority to test the *Athlete* to assume *Results Management* responsibility for the *Sample* or data if a potential anti-doping rule violation is discovered.³²

ARTICLE 7 RESULTS MANAGEMENT: RESPONSIBILITY, INITIAL REVIEW, NOTICE AND PROVISIONAL SUSPENSIONS

Results Management under these Anti-Doping Rules establishes a process designed to resolve anti-doping rule violation matters in a fair, expeditious and efficient manner.

7.1 Responsibility for Conducting *Results Management*

- 7.1.1** Except as otherwise provided in Articles 6.6, 6.8 and Code Article 7.1, *Results Management* shall be the responsibility of, and shall be governed by, the procedural rules of the *Anti-Doping Organization* that initiated and directed *Sample* collection (or, if no *Sample* collection is involved, the *Anti-Doping Organization* which first provides notice to an *Athlete* or other Person of a potential anti-doping rule violation and then diligently pursues that anti-doping rule violation).
- 7.1.2** In circumstances where the rules of a *National Anti-Doping Organization* do not give the *National Anti-Doping Organization* authority over an *Athlete* or other Person who is not a national, resident, license holder, or member of a sport organization of that country, or the *National Anti-Doping Organization* declines to exercise such authority, *Results Management* shall be conducted by the applicable International Federation or by a third party with authority over the *Athlete* or other Person as directed by the rules of the applicable International Federation.
- 7.1.3** In the event the *Major Event Organization* assumes only limited *Results Management* responsibility relating to a *Sample* initiated and taken during an *Event* conducted by a *Major Event Organization*, or an anti-doping rule violation occurring during such *Event*, the case shall be referred by the *Major Event Organization* to the applicable International Federation for completion of *Results Management*.
- 7.1.4** *Results Management* in relation to a potential whereabouts failure (a filing failure or a missed test) shall be administered by the UIM or the *National Anti-Doping Organization* with whom the *Athlete* in question files whereabouts information, as provided in the *International Standard for Results Management*. If the UIM determines a filing failure or a missed test, it shall submit that information to WADA through ADAMS, where it will be made available to other relevant *Anti-Doping Organizations*.
- 7.1.5** Other circumstances in which the UIM shall take responsibility for conducting *Results Management* in respect of anti-doping rule violations involving *Athletes* and other Persons under its authority shall be determined by reference to and in accordance with Article 7 of the Code.
- 7.1.6** WADA may direct the UIM to conduct *Results Management* in particular circumstances. If the UIM refuses to conduct *Results Management* within a reasonable deadline set by WADA, such refusal shall be considered an act of non-compliance, and WADA may direct another *Anti-Doping Organization* with authority over the *Athlete* or other Person,

³² [Comment to Article 6.8: Resistance or refusal to WADA taking physical possession of Samples or data could constitute Tampering, Complicity or an act of non-compliance as provided in the International Standard for Code Compliance by Signatories, and could also constitute a violation of the International Standard for Laboratories. Where necessary, the laboratory and/or the Anti-Doping Organization shall assist WADA in ensuring that the seized Sample or data are not delayed in exiting the applicable country.]

WADA would not, of course, unilaterally take possession of Samples or analytical data without good cause related to a potential anti-doping rule violation, non-compliance by a Signatory or doping activities by another Person. However, the decision as to whether good cause exists is for WADA to make in its discretion and shall not be subject to challenge. In particular, whether there is good cause or not shall not be a defense against an anti-doping rule violation or its Consequences.]

that is willing to do so, to take *Results Management* responsibility in place of the UIM or, if there is no such *Anti-Doping Organization*, any other *Anti-Doping Organization* that is willing to do so. In such case, the UIM shall reimburse the costs and attorney's fees of conducting *Results Management* to the other *Anti-Doping Organization* designated by WADA, and a failure to reimburse costs and attorney's fees shall be considered an act of non-compliance.

7.2 Review and Notification Regarding Potential Anti-Doping Rule Violations

The UIM shall carry out the review and notification with respect to any potential anti-doping rule violation in accordance with the *International Standard for Results Management*.

7.3 Identification of Prior Anti-Doping Rule Violations

Before giving an *Athlete* or other *Person* notice of a potential anti-doping rule violation as provided above, the UIM shall refer to ADAMS and contact WADA and other relevant *Anti-Doping Organizations* to determine whether any prior anti-doping rule violation exists.

7.4 Provisional Suspensions³³

7.4.1 Mandatory Provisional Suspension after an Adverse Analytical Finding or Adverse Passport Finding

If the UIM receives an *Adverse Analytical Finding* or an *Adverse Passport Finding* (upon completion of the *Adverse Passport Finding* review process) for a *Prohibited Substance* or a *Prohibited Method* that is not a *Specified Substance* or a *Specified Method*, the UIM shall impose a *Provisional Suspension* on the *Athlete* promptly upon or after the review and notification required by Article 7.2.

A mandatory *Provisional Suspension* may be eliminated if: (i) the *Athlete* demonstrates to the UIM Anti-Doping Hearing Panel that the violation is likely to have involved a *Contaminated Product*, or (ii) the violation involves a *Substance of Abuse* and the *Athlete* establishes entitlement to a reduced period of *Ineligibility* under Article 10.2.4.1.

The UIM Anti-Doping Hearing Panel's decision not to eliminate a mandatory *Provisional Suspension* on account of the *Athlete's* assertion regarding a *Contaminated Product* shall not be appealable.

7.4.2 Optional Provisional Suspension Based on an Adverse Analytical Finding for Specified Substances, Specified Methods, Contaminated Products, or Other Anti-Doping Rule Violations

The UIM may impose a *Provisional Suspension* for anti-doping rule violations not covered by Article 7.4.1 prior to the analysis of the *Athlete's* B Sample or final hearing as described in Article 8.

An optional *Provisional Suspension* may be lifted at the discretion of the UIM at any time prior to the UIM Anti-Doping Hearing Panel's decision under Article 8, unless provided otherwise in the *International Standard for Results Management*.

7.4.3 Opportunity for Hearing or Appeal

Notwithstanding Articles 7.4.1 and 7.4.2, a *Provisional Suspension* may not be imposed unless the *Athlete* or other *Person* is given: (a) an opportunity for a *Provisional Hearing*, either before or on a timely basis after imposition of the *Provisional Suspension*; or (b) an opportunity for an expedited hearing in accordance with Article 8 on a timely basis after imposition of the *Provisional Suspension*.

The imposition of a *Provisional Suspension*, or the decision not to impose a *Provisional Suspension*, may be appealed in an expedited process in accordance with Article 13.2.

³³ [Comment to Article 7.4: Before a Provisional Suspension can be unilaterally imposed by the UIM, the internal review specified in these Anti-Doping Rules and the International Standard for Results Management must first be completed.]

7.4.4 Voluntary Acceptance of *Provisional Suspension*

Athletes on their own initiative may voluntarily accept a *Provisional Suspension* if done so prior to the later of: (i) the expiration of ten (10) days from the report of the B *Sample* (or waiver of the B *Sample*) or ten (10) days from the notice of any other anti-doping rule violation, or (ii) the date on which the *Athlete* first competes after such report or notice.

Other *Persons* on their own initiative may voluntarily accept a *Provisional Suspension* if done so within ten (10) days from the notice of the anti-doping rule violation.

Upon such voluntary acceptance, the *Provisional Suspension* shall have the full effect and be treated in the same manner as if the *Provisional Suspension* had been imposed under Article 7.4.1 or 7.4.2; provided, however, at any time after voluntarily accepting a *Provisional Suspension*, the *Athlete* or other *Person* may withdraw such acceptance, in which event the *Athlete* or other *Person* shall not receive any credit for time previously served during the *Provisional Suspension*.

- 7.4.5** If a *Provisional Suspension* is imposed based on an A *Sample Adverse Analytical Finding* and a subsequent B *Sample* analysis (if requested by the *Athlete* or the UIM) does not confirm the A *Sample* analysis, then the *Athlete* shall not be subject to any further *Provisional Suspension* on account of a violation of Article 2.1. In circumstances where the *Athlete* (or the *Athlete's* team has been removed from an *Event* based on a violation of Article 2.1 and the subsequent B *Sample* analysis does not confirm the A *Sample* finding, then, if it is still possible for the *Athlete* or team to be reinserted, without otherwise affecting the *Event*, the *Athlete* or team may continue to take part in the *Event*.

7.5 Results Management Decisions

Results Management decisions or adjudications by the UIM must not purport to be limited to a particular geographic area or the UIM's sport and shall address and determine without limitation the following issues: (i) whether an anti-doping rule violation was committed or a *Provisional Suspension* should be imposed, the factual basis for such determination, and the specific Articles that have been violated, and (ii) all *Consequences* flowing from the anti-doping rule violation(s), including applicable *Disqualifications* under Articles 9 and 10.10, any forfeiture of medals or prizes, any period of *Ineligibility* (and the date it begins to run) and any *Financial Consequences*.³⁴

7.6 Notification of *Results Management* Decisions

The UIM shall notify *Athletes*, other *Persons*, *Signatories* and WADA of *Results Management* decisions as provided in Article 14.2 and in the *International Standard for Results Management*.

7.7 Retirement from Sport³⁵

If an *Athlete* or other *Person* retires while the UIM's *Results Management* process is underway, the UIM retains authority to complete its *Results Management* process. If an *Athlete* or other *Person* retires before any *Results Management* process has begun, and the UIM would have had *Results Management* authority over the *Athlete* or other *Person* at the time the *Athlete* or other *Person* committed an anti-doping rule violation, the UIM has authority to conduct *Results Management*.

³⁴ [Comment to Article 7.5: *Results Management* decisions include *Provisional Suspensions*.

Each decision by the UIM should address whether an anti-doping rule violation was committed and all *Consequences* flowing from the violation, including any *Disqualifications* other than *Disqualification* under Article 10.1 (which is left to the ruling body for an *Event*). Pursuant to Article 15, such decision and its imposition of *Consequences* shall have automatic effect in every sport in every country. For example, for a determination that an *Athlete* committed an anti-doping rule violation based on an *Adverse Analytical Finding* for a *Sample* taken *In-Competition*, the *Athlete's* results obtained in the *Competition* would be *Disqualified* under Article 9 and all other competitive results obtained by the *Athlete* from the date the *Sample* was collected through the duration of the period of *Ineligibility* are also *Disqualified* under Article 10.10; if the *Adverse Analytical Finding* resulted from *Testing* at an *Event*, it would be the *Major Event Organization's* responsibility to decide whether the *Athlete's* other individual results in the *Event* prior to *Sample* collection are also *Disqualified* under Article 10.1.]

³⁵ [Comment to Article 7.7: Conduct by an *Athlete* or other *Person* before the *Athlete* or other *Person* was subject to the authority of any *Anti-Doping Organization* would not constitute an anti-doping rule violation but could be a legitimate basis for denying the *Athlete* or other *Person* membership in a sports organization.]

ARTICLE 8 RESULTS MANAGEMENT: RIGHT TO A FAIR HEARING AND NOTICE OF HEARING DECISION

For any *Person* who is asserted to have committed an anti-doping rule violation, the UIM shall provide a fair hearing within a reasonable time by a fair, impartial and *Operationally Independent* hearing panel in compliance with the *Code* and the *International Standard for Results Management*.

8.1 Fair Hearings

8.1.1 Fair, Impartial and *Operationally Independent* Hearing Panel

- 8.1.1.1 The UIM shall establish a Hearing Panel [the UIM Anti-Doping Hearing Panel] which has jurisdiction to hear and determine whether an *Athlete* or other *Person*, subject to these Anti-Doping Rules, has committed an anti-doping rule violation and, if applicable, to impose relevant *Consequences*.
- 8.1.1.2 The UIM shall ensure that the UIM Anti-Doping Hearing Panel is free of conflict of interest and that its composition, term of office, professional experience, *Operational Independence* and adequate financing comply with the requirements of the *International Standard for Results Management*.
- 8.1.1.3 Board members, staff members, commission members, consultants and officials of the UIM or its affiliates (e.g. *National Authorities* or confederation), as well as any *Person* involved in the investigation and pre-adjudication of the matter, cannot be appointed as members and/or clerks (to the extent that such clerk is involved in the deliberation process and/or drafting of any decision) of the UIM Anti-Doping Hearing Panel. In particular, no member shall have previously considered any *TUE* application, *Results Management* decision, or appeals in the same given case.
- 8.1.1.4 The UIM Anti-Doping Hearing Panel shall consist of an independent Chair and two (2) other independent members.
- 8.1.1.5 Each member shall be appointed by taking into consideration their requisite anti-doping experience including their legal, sports, medical and/or scientific expertise. Each member shall be appointed for a once renewable term of three (3) years.
- 8.1.1.6 The UIM Anti-Doping Hearing Panel shall be in a position to conduct the hearing and decision-making process without interference from the UIM or any third party.

8.1.2 Hearing Process

- 8.1.2.1 When the UIM sends a notice to an *Athlete* or other *Person* notifying them of a potential anti-doping rule violation, and the *Athlete* or other *Person* does not waive a hearing in accordance with Article 8.3.1 or Article 8.3.2, then the case shall be referred to the UIM Anti-Doping Hearing Panel for hearing and adjudication, which shall be conducted in accordance with the principles described in Articles 8 and 9 of the *International Standard for Results Management*.
- 8.1.2.2 The Chair shall appoint three (3) members (which may include the Chair) to hear that case. When hearing a case, one (1) panel member shall be a qualified lawyer, with no less than three (3) years of relevant legal experience, and one (1) panel member shall be a qualified medical practitioner, with no less than three (3) years of relevant medical experience.

- 8.1.2.3** Upon appointment by the Chair as a member of the UIM Anti-Doping Hearing Panel, each member must also sign a declaration that there are no facts or circumstances known to him or her which might call into question their impartiality in the eyes of any of the parties, other than those circumstances disclosed in the declaration.
- 8.1.2.4** Hearings held in connection with *Events* in respect to *Athletes* and other *Persons* who are subject to these Anti-Doping Rules may be conducted by an expedited process where permitted by the UIM Anti-Doping Hearing Panel.³⁶
- 8.1.2.5** WADA, the *National Authority* and the *National Anti-Doping Organization* of the *Athlete* or other *Person* may attend the hearing as observers. In any event, the UIM shall keep them fully apprised as to the status of pending cases and the result of all hearings.

8.2 Notice of Decisions

- 8.2.1** At the end of the hearing, or promptly thereafter, the UIM Anti-Doping Hearing Panel shall issue a written decision that conforms with Article 9 of the *International Standard for Results Management* and which includes the full reasons for the decision, the period of *Ineligibility* imposed, the *Disqualification* of results under Article 10.10 and, if applicable, a justification for why the greatest potential *Consequences* were not imposed.
- 8.2.2** The UIM shall notify that decision to the *Athlete* or other *Person* and to other *Anti-Doping Organizations* with a right to appeal under Article 13.2.3, and shall promptly report it into ADAMS. The decision may be appealed as provided in Article 13.

8.3 Waiver of Hearing

- 8.3.1** An *Athlete* or other *Person* against whom an anti-doping violation is asserted may waive a hearing expressly and agree with the *Consequences* proposed by the UIM.
- 8.3.2** However, if the *Athlete* or other *Person* against whom an anti-doping rule violation is asserted fails to dispute that assertion within twenty (20) days or the deadline otherwise specified in the notice sent by the UIM asserting the violation, then they shall be deemed to have waived a hearing, to have admitted the violation, and to have accepted the proposed *Consequences*.
- 8.3.3** In cases where Article 8.3.1 or 8.3.2 applies, a hearing before the UIM Anti-Doping Hearing Panel shall not be required. Instead the UIM shall promptly issue a written decision that conforms with Article 9 of the *International Standard for Results Management* and which includes the full reasons for the decision, the period of *Ineligibility* imposed, the *Disqualification* of results under Article 10.10 and, if applicable, a justification for why the greatest potential *Consequences* were not imposed.
- 8.3.4** The UIM shall notify that decision to the *Athlete* or other *Person* and to other *Anti-Doping Organizations* with a right to appeal under Article 13.2.3, and shall promptly report it into ADAMS. The UIM shall *Publicly Disclose* that decision in accordance with Article 14.3.2.

8.4 Single Hearing Before CAS

Anti-doping rule violations asserted against *International-Level Athletes*, *National-Level Athletes* or other *Persons* may, with the consent of the *Athlete* or other *Person*, the UIM (where it has *Results Management* responsibility in accordance with Article 7) and WADA, be heard in a single hearing directly at CAS.³⁷

³⁶ [Comment to Article 8.1.2.4: For example, a hearing could be expedited on the eve of a major Event where the resolution of the anti-doping rule violation is necessary to determine the Athlete's eligibility to participate in the Event, or during an Event where the resolution of the case will affect the validity of the Athlete's results or continued participation in the Event.]

³⁷ [Comment to Article 8.4: In some cases, the combined cost of holding a hearing in the first instance at the international or national level, then rehearing the case de novo before CAS can be very substantial. Where all of the parties identified in this Article are satisfied that their interests will be adequately protected in a single hearing, there is no need for the Athlete or Anti-Doping Organizations to incur the extra expense of two (2) hearings. An Anti-Doping Organization may participate in the CAS hearing as an observer. Nothing set out in Article 8.4 precludes the Athlete or other Person and the UIM (where it has Results Management responsibility) to waive their right to appeal by

ARTICLE 9 AUTOMATIC DISQUALIFICATION OF INDIVIDUAL RESULTS

An anti-doping rule violation in *Individual Sports* in connection with an *In-Competition* test automatically leads to *Disqualification* of the result obtained in that *Competition* with all resulting *Consequences*, including forfeiture of any medals, points and prizes.³⁸

ARTICLE 10 SANCTIONS ON INDIVIDUALS

10.1 Disqualification of Results in the Event during which an Anti-Doping Rule Violation Occurs

- 10.1.1** An anti-doping rule violation occurring during or in connection with an *Event* may, upon the decision of the ruling body of the *Event*, lead to *Disqualification* of all of the *Athlete's* individual results obtained in that *Event* with all *Consequences*, including forfeiture of all medals, points and prizes, except as provided in Article 10.1.2.

Factors to be included in considering whether to *Disqualify* other results in an *Event* might include, for example, the seriousness of the *Athlete's* anti-doping rule violation and whether the *Athlete* tested negative in the other *Competitions*.³⁹

- 10.1.2** If the *Athlete* establishes that he or she bears *No Fault* or *Negligence* for the violation, the *Athlete's* individual results in the other *Competitions* shall not be *Disqualified*, unless the *Athlete's* results in *Competitions* other than the *Competition* in which the anti-doping rule violation occurred were likely to have been affected by the *Athlete's* anti-doping rule violation.

10.2 Ineligibility for Presence, Use or Attempted Use, or Possession of a Prohibited Substance or Prohibited Method

The period of *Ineligibility* for a violation of Article 2.1, 2.2 or 2.6 shall be as follows, subject to potential elimination, reduction or suspension pursuant to Article 10.5, 10.6 or 10.7:

- 10.2.1** The period of *Ineligibility*, subject to Article 10.2.4, shall be four (4) years where:
- 10.2.1.1** The anti-doping rule violation does not involve a *Specified Substance* or a *Specified Method*, unless the *Athlete* or other *Person* can establish that the anti-doping rule violation was not intentional.⁴⁰
 - 10.2.1.2** The anti-doping rule violation involves a *Specified Substance* or a *Specified Method* and the UIM can establish that the anti-doping rule violation was intentional.
- 10.2.2** If Article 10.2.1 does not apply, subject to Article 10.2.4.1, the period of *Ineligibility* shall be two (2) years.

agreement. Such waiver, however, only binds the parties to such agreement and not any other entity with a right of appeal under the Code.]

³⁸ [Comment to Article 9: For Team Sports, any awards received by individual players will be *Disqualified*. However, *Disqualification* of the team will be as provided in Article 11. In sports which are not Team Sports but where awards are given to teams, *Disqualification* or other disciplinary action against the team when one or more team members have committed an anti-doping rule violation shall be as provided in the applicable rules of the International Federation.]

³⁹ [Comment to Article 10.1.1: Whereas Article 9 *Disqualifies* the result in a single *Competition* in which the *Athlete* tested positive (e.g., the 100 meter backstroke), this Article may lead to *Disqualification* of all results in all races during the *Event* (e.g., the swimming World Championships).]

⁴⁰ [Comment to Article 10.2.1.1: While it is theoretically possible for an *Athlete* or other *Person* to establish that the anti-doping rule violation was not intentional without showing how the *Prohibited Substance* entered one's system, it is highly unlikely that in a doping case under Article 2.1 an *Athlete* will be successful in proving that the *Athlete* acted unintentionally without establishing the source of the *Prohibited Substance*.]

- 10.2.3** As used in Article 10.2, the term “intentional” is meant to identify those *Athletes* or other *Persons* who engage in conduct which they knew constituted an anti-doping rule violation or knew that there was a significant risk that the conduct might constitute or result in an anti-doping rule violation and manifestly disregarded that risk. An anti-doping rule violation resulting from an *Adverse Analytical Finding* for a substance which is only prohibited *In-Competition* shall be rebuttably presumed to be not “intentional” if the substance is a *Specified Substance* and the *Athlete* can establish that the *Prohibited Substance* was *Used Out-of-Competition*. An anti-doping rule violation resulting from an *Adverse Analytical Finding* for a substance which is only prohibited *In-Competition* shall not be considered “intentional” if the substance is not a *Specified Substance* and the *Athlete* can establish that the *Prohibited Substance* was *Used Out-of-Competition* in a context unrelated to sport performance.⁴¹
- 10.2.4** Notwithstanding any other provision in Article 10.2, where the anti-doping rule violation involves a *Substance of Abuse*:
- 10.2.4.1** If the *Athlete* can establish that any ingestion or *Use* occurred *Out-of-Competition* and was unrelated to sport performance, then the period of *Ineligibility* shall be three (3) months *Ineligibility*.
- In addition, the period of *Ineligibility* calculated under this Article 10.2.4.1 may be reduced to one (1) month if the *Athlete* or other *Person* satisfactorily completes a *Substance of Abuse* treatment program approved by the UIM. The period of *Ineligibility* established in this Article 10.2.4.1 is not subject to any reduction based on any provision in Article 10.6.⁴²
- 10.2.4.2** If the ingestion, *Use* or *Possession* occurred *In-Competition*, and the *Athlete* can establish that the context of the ingestion, *Use* or *Possession* was unrelated to sport performance, then the ingestion, *Use* or *Possession* shall not be considered intentional for purposes of Article 10.2.1 and shall not provide a basis for a finding of *Aggravating Circumstances* under Article 10.4.

10.3 *Ineligibility* for Other Anti-Doping Rule Violations

The period of *Ineligibility* for anti-doping rule violations other than as provided in Article 10.2 shall be as follows, unless Article 10.6 or 10.7 are applicable:

- 10.3.1** For violations of Article 2.3 or 2.5, the period of *Ineligibility* shall be four (4) years except: (i) in the case of failing to submit to *Sample* collection, if the *Athlete* can establish that the commission of the anti-doping rule violation was not intentional, the period of *Ineligibility* shall be two (2) years; (ii) in all other cases, if the *Athlete* or other *Person* can establish exceptional circumstances that justify a reduction of the period of *Ineligibility*, the period of *Ineligibility* shall be in a range from two (2) years to four (4) years depending on the *Athlete* or other *Person's* degree of *Fault*; or (iii) in a case involving a *Protected Person* or *Recreational Athlete*, the period of *Ineligibility* shall be in a range between a maximum of two (2) years and, at a minimum, a reprimand and no period of *Ineligibility*, depending on the *Protected Person* or *Recreational Athlete's* degree of *Fault*.
- 10.3.2** For violations of Article 2.4, the period of *Ineligibility* shall be two (2) years, subject to reduction down to a minimum of one (1) year, depending on the *Athlete's* degree of *Fault*. The flexibility between two (2) years and one (1) year of *Ineligibility* in this Article is not available to *Athletes* where a pattern of last-minute whereabouts changes or other conduct raises a serious suspicion that the *Athlete* was trying to avoid being available for *Testing*.

⁴¹ [Comment to Article 10.2.3: Article 10.2.3 provides a special definition of “intentional” which is to be applied solely for purposes of Article 10.2.]

⁴² [Comment to Article 10.2.4.1: The determinations as to whether the treatment program is approved and whether the *Athlete* or other *Person* has satisfactorily completed the program shall be made in the sole discretion of the UIM. This Article is intended to give the UIM the leeway to apply their own judgment to identify and approve legitimate and reputable, as opposed to “sham”, treatment programs. It is anticipated, however, that the characteristics of legitimate treatment programs may vary widely and change over time such that it would not be practical for WADA to develop mandatory criteria for acceptable treatment programs.]

- 10.3.3** For violations of Article 2.7 or 2.8, the period of *Ineligibility* shall be a minimum of four (4) years up to lifetime *Ineligibility*, depending on the seriousness of the violation. An Article 2.7 or Article 2.8 violation involving a *Protected Person* shall be considered a particularly serious violation and, if committed by *Athlete Support Personnel* for violations other than for *Specified Substances*, shall result in lifetime *Ineligibility* for *Athlete Support Personnel*. In addition, significant violations of Article 2.7 or 2.8 which may also violate non-sporting laws and regulations, shall be reported to the competent administrative, professional or judicial authorities.⁴³
- 10.3.4** For violations of Article 2.9, the period of *Ineligibility* imposed shall be a minimum of two (2) years, up to lifetime *Ineligibility*, depending on the seriousness of the violation.
- 10.3.5** For violations of Article 2.10, the period of *Ineligibility* shall be two (2) years, subject to reduction down to a minimum of one (1) year, depending on the *Athlete* or other *Person's* degree of *Fault* and other circumstances of the case.⁴⁴
- 10.3.6** For violations of Article 2.11, the period of *Ineligibility* shall be a minimum of two (2) years, up to lifetime *Ineligibility*, depending on the seriousness of the violation by the *Athlete* or other *Person*.⁴⁵

10.4 **Aggravating Circumstances which may Increase the Period of *Ineligibility***

If the UIM establishes in an individual case involving an anti-doping rule violation other than violations under Article 2.7 (*Trafficking* or *Attempted Trafficking*), 2.8 (*Administration* or *Attempted Administration*), 2.9 (*Complicity*) or 2.11 (*Acts by an Athlete or Other Person to Discourage or Retaliate Against Reporting*) that *Aggravating Circumstances* are present which justify the imposition of a period of *Ineligibility* greater than the standard sanction, then the period of *Ineligibility* otherwise applicable shall be increased by an additional period of *Ineligibility* of up to two (2) years depending on the seriousness of the violation and the nature of the *Aggravating Circumstances*, unless the *Athlete* or other *Person* can establish that he or she did not knowingly commit the anti-doping rule violation.⁴⁶

10.5 **Elimination of the Period of *Ineligibility* where there is *No Fault* or *Negligence***

If an *Athlete* or other *Person* establishes in an individual case that he or she bears *No Fault* or *Negligence*, then the otherwise applicable period of *Ineligibility* shall be eliminated.⁴⁷

⁴³ [Comment to Article 10.3.3: Those who are involved in doping Athletes or covering up doping should be subject to sanctions which are more severe than the Athletes who test positive. Since the authority of sport organizations is generally limited to *Ineligibility* for accreditation, membership and other sport benefits, reporting Athlete Support Personnel to competent authorities is an important step in the deterrence of doping.]

⁴⁴ [Comment to Article 10.3.5: Where the "other Person" referenced in Article 2.10 is an entity and not an individual, that entity may be disciplined as provided in Article 12.]

⁴⁵ [Comment to Article 10.3.6: Conduct that is found to violate both Article 2.5 (*Tampering*) and Article 2.11 (*Acts by an Athlete or Other Person to Discourage or Retaliate Against Reporting to Authorities*) shall be sanctioned based on the violation that carries the more severe sanction.]

⁴⁶ [Comment to Article 10.4: Violations under Articles 2.7 (*Trafficking* or *Attempted Trafficking*), 2.8 (*Administration* or *Attempted Administration*), 2.9 (*Complicity* or *Attempted Complicity*) and 2.11 (*Acts by an Athlete or Other Person to Discourage or Retaliate Against Reporting to Authorities*) are not included in the application of Article 10.4 because the sanctions for these violations already build in sufficient discretion up to a lifetime ban to allow consideration of any *Aggravating Circumstance*.]

⁴⁷ [Comment to Article 10.5: This Article and Article 10.6.2 apply only to the imposition of sanctions; they are not applicable to the determination of whether an anti-doping rule violation has occurred. They will only apply in exceptional circumstances, for example, where an Athlete could prove that, despite all due care, he or she was sabotaged by a competitor. Conversely, *No Fault* or *Negligence* would not apply in the following circumstances: (a) a positive test resulting from a mislabelled or contaminated vitamin or nutritional supplement (Athletes are responsible for what they ingest (Article 2.1) and have been warned against the possibility of supplement contamination); (b) the Administration of a Prohibited Substance by the Athlete's personal physician or trainer without disclosure to the Athlete (Athletes are responsible for their choice of medical personnel and for advising medical personnel that they cannot be given any Prohibited Substance); and (c) sabotage of the Athlete's food or drink by a spouse, coach or other Person within the Athlete's circle of associates (Athletes are responsible for what they ingest and for the conduct of those Persons to whom they entrust access to their food and drink). However, depending on the unique facts of a particular case, any of the referenced illustrations could result in a reduced sanction under Article 10.6 based on *No Significant Fault* or *Negligence*.]

10.6 Reduction of the Period of Ineligibility based on No Significant Fault or Negligence

10.6.1 Reduction of Sanctions in Particular Circumstances for Violations of Article 2.1, 2.2 or 2.6.

All reductions under Article 10.6.1 are mutually exclusive and not cumulative.

10.6.1.1 Specified Substances or Specified Methods

Where the anti-doping rule violation involves a *Specified Substance* (other than a *Substance of Abuse*) or *Specified Method*, and the *Athlete* or other *Person* can establish *No Significant Fault or Negligence*, then the period of *Ineligibility* shall be, at a minimum, a reprimand and no period of *Ineligibility*, and at a maximum, two (2) years of *Ineligibility*, depending on the *Athlete's* or other *Person's* degree of *Fault*.

10.6.1.2 Contaminated Products

In cases where the *Athlete* or other *Person* can establish both *No Significant Fault or Negligence* and that the detected *Prohibited Substance* (other than a *Substance of Abuse*) came from a *Contaminated Product*, then the period of *Ineligibility* shall be, at a minimum, a reprimand and no period of *Ineligibility*, and at a maximum, two (2) years *Ineligibility*, depending on the *Athlete* or other *Person's* degree of *Fault*.⁴⁸

10.6.1.3 Protected Persons or Recreational Athletes

Where the anti-doping rule violation not involving a *Substance of Abuse* is committed by a *Protected Person* or *Recreational Athlete*, and the *Protected Person* or *Recreational Athlete* can establish *No Significant Fault or Negligence*, then the period of *Ineligibility* shall be, at a minimum, a reprimand and no period of *Ineligibility*, and at a maximum, two (2) years *Ineligibility*, depending on the *Protected Person* or *Recreational Athlete's* degree of *Fault*.

10.6.2 Application of *No Significant Fault or Negligence* beyond the Application of Article 10.6.1

If an *Athlete* or other *Person* establishes in an individual case where Article 10.6.1 is not applicable that he or she bears *No Significant Fault or Negligence*, then, subject to further reduction or elimination as provided in Article 10.7, the otherwise applicable period of *Ineligibility* may be reduced based on the *Athlete* or other *Person's* degree of *Fault*, but the reduced period of *Ineligibility* may not be less than one-half of the period of *Ineligibility* otherwise applicable. If the otherwise applicable period of *Ineligibility* is a lifetime, the reduced period under this Article may be no less than eight (8) years.⁴⁹

⁴⁸ [Comment to Article 10.6.1.2: In order to receive the benefit of this Article, the *Athlete* or other *Person* must establish not only that the detected *Prohibited Substance* came from a *Contaminated Product*, but must also separately establish *No Significant Fault or Negligence*. It should be further noted that *Athletes* are on notice that they take nutritional supplements at their own risk. The sanction reduction based on *No Significant Fault or Negligence* has rarely been applied in *Contaminated Product* cases unless the *Athlete* has exercised a high level of caution before taking the *Contaminated Product*. In assessing whether the *Athlete* can establish the source of the *Prohibited Substance*, it would, for example, be significant for purposes of establishing whether the *Athlete* actually Used the *Contaminated Product*, whether the *Athlete* had declared the product which was subsequently determined to be contaminated on the *Doping Control* form.]

This Article should not be extended beyond products that have gone through some process of manufacturing. Where an Adverse Analytical Finding results from environment contamination of a “non-product” such as tap water or lake water in circumstances where no reasonable person would expect any risk of an anti-doping rule violation, typically there would be *No Fault or Negligence* under Article 10.5.]

⁴⁹ [Comment to Article 10.6.2: Article 10.6.2 may be applied to any anti-doping rule violation except those Articles where intent is an element of the anti-doping rule violation (e.g., Article 2.5, 2.7, 2.8, 2.9 or 2.11) or an element of a particular sanction (e.g., Article 10.2.1) or a range of *Ineligibility* is already provided in an Article based on the *Athlete* or other *Person's* degree of *Fault*.]

10.7 Elimination, Reduction, or Suspension of Period of *Ineligibility* or Other *Consequences* for Reasons Other than *Fault*

10.7.1 *Substantial Assistance* in Discovering or Establishing Code Violations⁵⁰

10.7.1.1 The UIM may, prior to an appellate decision under Article 13 or the expiration of the time to appeal, suspend a part of the *Consequences* (other than *Disqualification* and mandatory *Public Disclosure*) imposed in an individual case where the *Athlete* or other *Person* has provided *Substantial Assistance* to an *Anti-Doping Organization*, criminal authority or professional disciplinary body which results in: (i) the *Anti-Doping Organization* discovering or bringing forward an anti-doping rule violation by another *Person*; or (ii) which results in a criminal or disciplinary body discovering or bringing forward a criminal offense or the breach of professional rules committed by another *Person* and the information provided by the *Person* providing *Substantial Assistance* is made available to the UIM or other *Anti-Doping Organization* with *Results Management* responsibility; or (iii) which results in WADA initiating a proceeding against a *Signatory*, WADA-accredited laboratory, or *Athlete* passport management unit (as defined in the *International Standard for Laboratories*) for non-compliance with the *Code*, *International Standard* or *Technical Document*; or (iv) with the approval by WADA, which results in a criminal or disciplinary body bringing forward a criminal offense or the breach of professional or sport rules arising out of a sport integrity violation other than doping. After an appellate decision under Article 13 or the expiration of time to appeal, the UIM may only suspend a part of the otherwise applicable *Consequences* with the approval of WADA.

The extent to which the otherwise applicable period of *Ineligibility* may be suspended shall be based on the seriousness of the anti-doping rule violation committed by the *Athlete* or other *Person* and the significance of the *Substantial Assistance* provided by the *Athlete* or other *Person* to the effort to eliminate doping in sport, non-compliance with the *Code* and/or sport integrity violations. No more than three-quarters of the otherwise applicable period of *Ineligibility* may be suspended. If the otherwise applicable period of *Ineligibility* is a lifetime, the non-suspended period under this Article must be no less than eight (8) years. For purposes of this paragraph, the otherwise applicable period of *Ineligibility* shall not include any period of *Ineligibility* that could be added under Article 10.9.3.2 of these Anti-Doping Rules.

If so requested by an *Athlete* or other *Person* who seeks to provide *Substantial Assistance*, the UIM shall allow the *Athlete* or other *Person* to provide the information to it subject to a *Without Prejudice Agreement*.

If the *Athlete* or other *Person* fails to continue to cooperate and to provide the complete and credible *Substantial Assistance* upon which a suspension of *Consequences* was based, the UIM shall reinstate the original *Consequences*. If the UIM decides to reinstate suspended *Consequences* or decides not to reinstate suspended *Consequences*, that decision may be appealed by any *Person* entitled to appeal under Article 13.

10.7.1.2 To further encourage *Athletes* and other *Persons* to provide *Substantial Assistance* to *Anti-Doping Organizations*, at the request of the UIM or at the request of the *Athlete* or other *Person* who has, or has been asserted to have, committed an anti-doping rule violation, or other violation of the *Code*, WADA may agree at any stage of the *Results Management* process, including after an appellate decision under Article 13, to what it considers to be an appropriate suspension of the otherwise-applicable period of *Ineligibility* and other *Consequences*. In exceptional circumstances, WADA may agree to suspensions of the period of *Ineligibility* and other *Consequences* for *Substantial Assistance* greater than those otherwise provided in this Article, or even no period of *Ineligibility*, no mandatory *Public Disclosure* and/or no return

⁵⁰ [Comment to Article 10.7.1: The cooperation of *Athletes*, *Athlete Support Personnel* and other *Persons* who acknowledge their mistakes and are willing to bring other anti-doping rule violations to light is important to clean sport.]

of prize money or payment of fines or costs. WADA's approval shall be subject to reinstatement of *Consequences*, as otherwise provided in this Article. Notwithstanding Article 13, WADA's decisions in the context of this Article 10.7.1.2 may not be appealed.

- 10.7.1.3** If the UIM suspends any part of an otherwise applicable sanction because of *Substantial Assistance*, then notice providing justification for the decision shall be provided to the other *Anti-Doping Organizations* with a right to appeal under Article 13.2.3 as provided in Article 14.2. In unique circumstances where WADA determines that it would be in the best interest of anti-doping, WADA may authorize the UIM to enter into appropriate confidentiality agreements limiting or delaying the disclosure of the *Substantial Assistance* agreement or the nature of *Substantial Assistance* being provided.

10.7.2 Admission of an Anti-Doping Rule Violation in the Absence of Other Evidence

Where an *Athlete* or other *Person* voluntarily admits the commission of an anti-doping rule violation before having received notice of a *Sample* collection which could establish an anti-doping rule violation (or, in the case of an anti-doping rule violation other than Article 2.1, before receiving first notice of the admitted violation pursuant to Article 7) and that admission is the only reliable evidence of the violation at the time of admission, then the period of *Ineligibility* may be reduced, but not below one-half of the period of *Ineligibility* otherwise applicable.⁵¹

10.7.3 Application of Multiple Grounds for Reduction of a Sanction

Where an *Athlete* or other *Person* establishes entitlement to reduction in sanction under more than one provision of Article 10.5, 10.6 or 10.7, before applying any reduction or suspension under Article 10.7, the otherwise applicable period of *Ineligibility* shall be determined in accordance with Articles 10.2, 10.3, 10.5, and 10.6. If the *Athlete* or other *Person* establishes entitlement to a reduction or suspension of the period of *Ineligibility* under Article 10.7, then the period of *Ineligibility* may be reduced or suspended, but not below one-fourth of the otherwise applicable period of *Ineligibility*.

10.8 Results Management Agreements

- 10.8.1** One (1) Year Reduction for Certain Anti-Doping Rule Violations Based on Early Admission and Acceptance of Sanction

Where an *Athlete* or other *Person*, after being notified by the UIM of a potential anti-doping rule violation that carries an asserted period of *Ineligibility* of four (4) or more years (including any period of *Ineligibility* asserted under Article 10.4), admits the violation and accepts the asserted period of *Ineligibility* no later than twenty (20) days after receiving notice of an anti-doping rule violation charge, the *Athlete* or other *Person* may receive a one (1) year reduction in the period of *Ineligibility* asserted by the UIM. Where the *Athlete* or other *Person* receives the one (1) year reduction in the asserted period of *Ineligibility* under this Article 10.8.1, no further reduction in the asserted period of *Ineligibility* shall be allowed under any other Article.⁵²

- 10.8.2** Case Resolution Agreement

Where the *Athlete* or other *Person* admits an anti-doping rule violation after being confronted with the anti-doping rule violation by the UIM and agrees to *Consequences* acceptable to the UIM and WADA, at their sole discretion, then: (a) the *Athlete* or other *Person* may receive a reduction in the period of *Ineligibility* based on an assessment by the UIM and WADA of the application of Articles

⁵¹ [Comment to Article 10.7.2: This Article is intended to apply when an *Athlete* or other *Person* comes forward and admits to an anti-doping rule violation in circumstances where no *Anti-Doping Organization* is aware that an anti-doping rule violation might have been committed. It is not intended to apply to circumstances where the admission occurs after the *Athlete* or other *Person* believes he or she is about to be caught. The amount by which *Ineligibility* is reduced should be based on the likelihood that the *Athlete* or other *Person* would have been caught had he or she not come forward voluntarily.]

⁵² [Comment to Article 10.8.1: For example, if the UIM alleges that an *Athlete* has violated Article 2.1 for Use of an anabolic steroid and asserts the applicable period of *Ineligibility* is four (4) years, then the *Athlete* may unilaterally reduce the period of *Ineligibility* to three (3) years by admitting the violation and accepting the three (3) year period of *Ineligibility* within the time specified in this Article, with no further reduction allowed. This resolves the case without any need for a hearing.]

10.1 through 10.7 to the asserted anti-doping rule violation, the seriousness of the violation, the *Athlete* or other *Person's* degree of *Fault* and how promptly the *Athlete* or other *Person* admitted the violation; and (b) the period of *Ineligibility* may start as early as the date of *Sample* collection or the date on which another anti-doping rule violation last occurred. In each case, however, where this Article is applied, the *Athlete* or other *Person* shall serve at least one-half of the agreed-upon period of *Ineligibility* going forward from the earlier of the date the *Athlete* or other *Person* accepted the imposition of a sanction or a *Provisional Suspension* which was subsequently respected by the *Athlete* or other *Person*. The decision by WADA and the UIM to enter or not enter into a case resolution agreement, and the amount of the reduction to, and the starting date of, the period of *Ineligibility* are not matters for determination or review by a hearing body and are not subject to appeal under Article 13.

If so requested by an *Athlete* or other *Person* who seeks to enter into a case resolution agreement under this Article, the UIM shall allow the *Athlete* or other *Person* to discuss an admission of the anti-doping rule violation with it subject to a *Without Prejudice Agreement*.⁵³

10.9 Multiple Violations

10.9.1 Second or Third Anti-Doping Rule Violation

10.9.1.1 For an *Athlete* or other *Person's* second anti-doping rule violation, the period of *Ineligibility* shall be the greater of:

(a) A six (6) month period of *Ineligibility*; or

(b) A period of *Ineligibility* in the range between:

- (i) the sum of the period of *Ineligibility* imposed for the first anti-doping rule violation plus the period of *Ineligibility* otherwise applicable to the second anti-doping rule violation treated as if it were a first violation, and
- (ii) twice the period of *Ineligibility* otherwise applicable to the second anti-doping rule violation treated as if it were a first violation. The period of *Ineligibility* shall be determined based on the entirety of the circumstances and the *Athlete* or other *Person's* degree of *Fault* with respect to the second violation.

10.9.1.2 A third anti-doping rule violation will always result in a lifetime period of *Ineligibility*, except if the third violation fulfils the condition for elimination or reduction of the period of *Ineligibility* under Article 10.5 or 10.6, or involves a violation of Article 2.4. In these particular cases, the period of *Ineligibility* shall be from eight (8) years to lifetime *Ineligibility*.

10.9.1.3 The period of *Ineligibility* established in Articles 10.9.1.1 and 10.9.1.2 may then be further reduced by the application of Article 10.7.

10.9.2 An anti-doping rule violation for which an *Athlete* or other *Person* has established *No Fault* or *Negligence* shall not be considered a violation for purposes of this Article 10.9. In addition, an anti-doping rule violation sanctioned under Article 10.2.4.1 shall not be considered a violation for purposes of Article 10.9.

10.9.3 Additional Rules for Certain Potential Multiple Violations

10.9.3.1 For purposes of imposing sanctions under Article 10.9, except as provided in Articles 10.9.3.2 and 10.9.3.3, an anti-doping rule violation will only be considered a second violation if the UIM can establish that the *Athlete* or other *Person* committed the additional anti-doping rule violation after the *Athlete* or other *Person* received notice pursuant to Article 7, or after the UIM made reasonable efforts to give notice of the first anti-doping rule violation. If the UIM

⁵³ [Comment to Article 10.8: Any mitigating or aggravating factors set forth in this Article 10 shall be considered in arriving at the Consequences set forth in the case resolution agreement, and shall not be applicable beyond the terms of that agreement.]

cannot establish this, the violations shall be considered together as one single first violation, and the sanction imposed shall be based on the violation that carries the more severe sanction, including the application of *Aggravating Circumstances*. Results in all *Competitions* dating back to the earlier anti-doping rule violation will be *Disqualified* as provided in Article 10.10.⁵⁴

- 10.9.3.2** If the UIM establishes that an *Athlete* or other *Person* committed an additional anti-doping rule violation prior to notification, and that the additional violation occurred twelve (12) months or more before or after the first-noticed violation, then the period of *Ineligibility* for the additional violation shall be calculated as if the additional violation were a stand-alone first violation and this period of *Ineligibility* is served consecutively, rather than concurrently, with the period of *Ineligibility* imposed for the earlier-noticed violation. Where this Article 10.9.3.2 applies, the violations taken together shall constitute a single violation for purposes of Article 10.9.1.
- 10.9.3.3** If the UIM establishes that an *Athlete* or other *Person* committed a violation of Article 2.5 in connection with the *Doping Control* process for an underlying asserted anti-doping rule violation, the violation of Article 2.5 shall be treated as a stand-alone first violation and the period of *Ineligibility* for such violation shall be served consecutively, rather than concurrently, with the period of *Ineligibility*, if any, imposed for the underlying anti-doping rule violation. Where this Article 10.9.3.3 is applied, the violations taken together shall constitute a single violation for purposes of Article 10.9.1.
- 10.9.3.4** If the UIM establishes that an *Athlete* or other *Person* has committed a second or third anti-doping rule violation during a period of *Ineligibility*, the periods of *Ineligibility* for the multiple violations shall run consecutively, rather than concurrently.

10.9.4 Multiple Anti-Doping Rule Violations during Ten (10) Year Period

For purposes of Article 10.9, each anti-doping rule violation must take place within the same ten (10) year period in order to be considered multiple violations.

10.10 Disqualification of Results in Competitions Subsequent to Sample Collection or Commission of an Anti-Doping Rule Violation

In addition to the automatic *Disqualification* of the results in the *Competition* which produced the positive *Sample* under Article 9, all other competitive results of the *Athlete* obtained from the date a positive *Sample* was collected (whether *In-Competition* or *Out-of-Competition*), or other anti-doping rule violation occurred, through the commencement of any *Provisional Suspension* or *Ineligibility* period, shall, unless fairness requires otherwise, be *Disqualified* with all of the resulting *Consequences* including forfeiture of any medals, points and prizes.⁵⁵

10.11 Forfeited Prize Money

If the UIM recovers prize money forfeited as a result of an anti-doping rule violation, it shall take reasonable measures to allocate and distribute this prize money to the *Athletes* who would have been entitled to it had the forfeiting *Athlete* not competed.⁵⁶

⁵⁴ [Comment to Article 10.9.3.1: The same rule applies where, after the imposition of a sanction, the UIM discovers facts involving an anti-doping rule violation that occurred prior to notification for a first anti-doping rule violation – e.g., the UIM shall impose a sanction based on the sanction that could have been imposed if the two (2) violations had been adjudicated at the same time, including the application of *Aggravating Circumstances*.]

⁵⁵ [Comment to Article 10.10: Nothing in these Anti-Doping Rules precludes clean *Athletes* or other *Persons* who have been damaged by the actions of a *Person* who has committed an anti-doping rule violation from pursuing any right which they would otherwise have to seek damages from such *Person*.]

⁵⁶ [Comment to Article 10.11: This Article is not intended to impose an affirmative duty on the UIM to take any action to collect forfeited prize money. If the UIM elects not to take any action to collect forfeited prize money, it may assign its right to recover such money to the *Athlete(s)* who should have otherwise received the money. "Reasonable measures to allocate and distribute this prize money" could include using collected forfeited prize money as agreed upon by the UIM and its *Athletes*.]

10.12 Financial Consequences

- 10.12.1** Where an *Athlete* or other *Person* commits an anti-doping rule violation, the UIM may, in its discretion and subject to the principle of proportionality, elect to (a) recover from the *Athlete* or other *Person* costs associated with the anti-doping rule violation, regardless of the period of *Ineligibility* imposed and/or (b) fine the *Athlete* or other *Person* in an amount up to 5'000 Euros, only in cases where the maximum period of *Ineligibility* otherwise applicable has already been imposed.
- 10.12.2** The imposition of a financial sanction or the UIM's recovery of costs shall not be considered a basis for reducing the *Ineligibility* or other sanction which would otherwise be applicable under these Anti-Doping Rules.

10.13 Commencement of *Ineligibility* Period

Where an *Athlete* is already serving a period of *Ineligibility* for an anti-doping rule violation, any new period of *Ineligibility* shall commence on the first day after the current period of *Ineligibility* has been served. Otherwise, except as provided below, the period of *Ineligibility* shall start on the date of the final hearing decision providing for *Ineligibility* or, if the hearing is waived or there is no hearing, on the date *Ineligibility* is accepted or otherwise imposed.

10.13.1 Delays Not Attributable to the *Athlete* or other *Person*

Where there have been substantial delays in the hearing process or other aspects of *Doping Control*, and the *Athlete* or other *Person* can establish that such delays are not attributable to the *Athlete* or other *Person*, the UIM or the UIM Anti-Doping Hearing Panel, if applicable, may start the period of *Ineligibility* at an earlier date commencing as early as the date of *Sample* collection or the date on which another anti-doping rule violation last occurred. All competitive results achieved during the period of *Ineligibility*, including retroactive *Ineligibility*, shall be *Disqualified*.⁵⁷

10.13.2 Credit for *Provisional Suspension* or Period of *Ineligibility* Served

- 10.13.2.1** If a *Provisional Suspension* is respected by the *Athlete* or other *Person*, then the *Athlete* or other *Person* shall receive a credit for such period of *Provisional Suspension* against any period of *Ineligibility* which may ultimately be imposed. If the *Athlete* or other *Person* does not respect a *Provisional Suspension*, then the *Athlete* or other *Person* shall receive no credit for any period of *Provisional Suspension* served. If a period of *Ineligibility* is served pursuant to a decision that is subsequently appealed, then the *Athlete* or other *Person* shall receive a credit for such period of *Ineligibility* served against any period of *Ineligibility* which may ultimately be imposed on appeal.
- 10.13.2.2** If an *Athlete* or other *Person* voluntarily accepts a *Provisional Suspension* in writing from the UIM and thereafter respects the *Provisional Suspension*, the *Athlete* or other *Person* shall receive a credit for such period of voluntary *Provisional Suspension* against any period of *Ineligibility* which may ultimately be imposed. A copy of the *Athlete* or other *Person*'s voluntary acceptance of a *Provisional Suspension* shall be provided promptly to each party entitled to receive notice of an asserted anti-doping rule violation under Article 14.1.⁵⁸
- 10.13.2.3** No credit against a period of *Ineligibility* shall be given for any time period before the effective date of the *Provisional Suspension* or voluntary

⁵⁷ [Comment to Article 10.13.1: In cases of anti-doping rule violations other than under Article 2.1, the time required for an Anti-Doping Organization to discover and develop facts sufficient to establish an anti-doping rule violation may be lengthy, particularly where the *Athlete* or other *Person* has taken affirmative action to avoid detection. In these circumstances, the flexibility provided in this Article to start the sanction at an earlier date should not be used.]

⁵⁸ [Comment to Article 10.13.2.2: An *Athlete*'s voluntary acceptance of a *Provisional Suspension* is not an admission by the *Athlete* and shall not be used in any way to draw an adverse inference against the *Athlete*.]

Provisional Suspension regardless of whether the *Athlete* elected not to compete or was suspended by a team.

- 10.13.2.4** In *Team Sports*, where a period of *Ineligibility* is imposed upon a team, unless fairness requires otherwise, the period of *Ineligibility* shall start on the date of the final hearing decision providing for *Ineligibility* or, if the hearing is waived, on the date *Ineligibility* is accepted or otherwise imposed. Any period of team *Provisional Suspension* (whether imposed or voluntarily accepted) shall be credited against the total period of *Ineligibility* to be served.]

10.14 Status During Ineligibility or Provisional Suspension

10.14.1 Prohibition Against Participation During *Ineligibility* or *Provisional Suspension*

No *Athlete* or other *Person* who has been declared *Ineligible* or is subject to a *Provisional Suspension* may, during a period of *Ineligibility* or *Provisional Suspension*, participate in any capacity in a *Competition* or activity (other than authorized anti-doping *Education* or rehabilitation programs) authorized or organized by any *Signatory*, *Signatory's* member organization, or a club or other member organization of a *Signatory's* member organization, or in *Competitions* authorized or organized by any professional league or any international- or national-level *Event* organization or any elite or national-level sporting activity funded by a governmental agency.

An *Athlete* or other *Person* subject to a period of *Ineligibility* longer than four (4) years may, after completing four (4) years of the period of *Ineligibility*, participate as an *Athlete* in local sport events not sanctioned or otherwise under the authority of a *Code Signatory* or member of a *Code Signatory*, but only so long as the local sport event is not at a level that could otherwise qualify such *Athlete* or other *Person* directly or indirectly to compete in (or accumulate points toward) a national championship or *International Event*, and does not involve the *Athlete* or other *Person* working in any capacity with *Protected Persons*.

An *Athlete* or other *Person* subject to a period of *Ineligibility* shall remain subject to *Testing* and any requirement by the UIM to provide whereabouts information.⁵⁹

10.14.2 Return to Training

As an exception to Article 10.14.1, an *Athlete* may return to train with a team or to use the facilities of a club or other member organization of the UIM's or other *Signatory's* member organization during the shorter of: (1) the last two months of the *Athlete's* period of *Ineligibility*, or (2) the last one-quarter of the period of *Ineligibility* imposed.⁶⁰

10.14.3 Violation of the Prohibition of Participation During *Ineligibility* or *Provisional Suspension*

Where an *Athlete* or other *Person* who has been declared *Ineligible* violates the prohibition against participation during *Ineligibility* described in Article 10.14.1, the results of such participation shall be *Disqualified* and a new period of *Ineligibility* equal in length to the original period of *Ineligibility* shall be added to the end of the original period of *Ineligibility*. The new period of *Ineligibility*, including a reprimand and no period of *Ineligibility*, may be adjusted based on the *Athlete* or other *Person's* degree of *Fault* and other circumstances of the case. The determination of whether an *Athlete* or other *Person* has violated the prohibition against participation, and whether an adjustment is appropriate, shall be made by the *Anti-Doping Organization* whose *Results Management* led to the imposition of the initial period of *Ineligibility*. This decision may be appealed under Article 13.

⁵⁹ [Comment to Article 10.14.1: For example, subject to Article 10.14.2 below, *Ineligible Athletes* cannot participate in a training camp, exhibition or practice organized by their National Authority or a club which is a member of that National Authority or which is funded by a governmental agency. Further, an *Ineligible Athlete* may not compete in a non-*Signatory* professional league (e.g., the National Hockey League, the National Basketball Association, etc.), Events organized by a non-*Signatory* International Event organization or a non-*Signatory* national-level Event organization without triggering the Consequences set forth in Article 10.14.3. The term "activity" also includes, for example, administrative activities, such as serving as an official, director, officer, employee, or volunteer of the organization described in this Article. *Ineligibility* imposed in one sport shall also be recognized by other sports (see Article 15.1, Automatic Binding Effect of Decisions). An *Athlete* or other *Person* serving a period of *Ineligibility* is prohibited from coaching or serving as an *Athlete Support Person* in any other capacity at any time during the period of *Ineligibility*, and doing so could also result in a violation of Article 2.10 by another *Athlete*. Any performance standard accomplished during a period of *Ineligibility* shall not be recognized by the UIM or its National Authorities for any purpose.]

⁶⁰ [Comment to Article 10.14.2: In many *Team Sports* and some individual sports (e.g., ski jumping and gymnastics), *Athletes* cannot effectively train on their own so as to be ready to compete at the end of the *Athlete's* period of *Ineligibility*. During the training period described in this Article, an *Ineligible Athlete* may not compete or engage in any activity described in Article 10.14.1 other than training.]

An *Athlete* or other *Person* who violates the prohibition against participation during a *Provisional Suspension* described in Article 10.14.1 shall receive no credit for any period of *Provisional Suspension* served and the results of such participation shall be *Disqualified*.

Where an *Athlete Support Person* or other *Person* assists a *Person* in violating the prohibition against participation during *Ineligibility* or a *Provisional Suspension*, the UIM shall impose sanctions for a violation of Article 2.9 for such assistance.

10.14.4 Withholding of Financial Support during *Ineligibility*

In addition, for any anti-doping rule violation not involving a reduced sanction as described in Article 10.5 or 10.6, some or all sport-related financial support or other sport-related benefits received by such *Person* will be withheld by the UIM and its *National Authorities*.

10.15 Automatic Publication of Sanction

A mandatory part of each sanction shall include automatic publication, as provided in Article 14.3.

ARTICLE 11 CONSEQUENCES TO TEAMS

11.1 Testing of Teams

Where one (1) member of a team (outside of *Team Sports*) has been notified of an anti-doping rule violation under Article 7 in connection with an *Event*, the ruling body for the *Event* shall conduct appropriate *Target Testing* of all members of the team during the *Event Period*.

11.2 Consequences for Teams

11.2.1 An anti-doping rule violation committed by a member of a team in connection with an *In-Competition* test automatically leads to *Disqualification* of the result obtained by the team in that *Competition*, with all resulting *Consequences* for the team and its members, including forfeiture of any medals, points and prizes.

11.2.2 An anti-doping rule violation committed by a member of a team occurring during or in connection with an *Event* may lead to *Disqualification* of all of the results obtained by the team in that *Event* with all *Consequences* for the team and its members, including forfeiture of all medals, points and prizes, except as provided in Article 11.2.3.

11.2.3 Where an *Athlete* who is a member of a team committed an anti-doping rule violation during or in connection with one (1) *Competition* in an *Event*, if the other member(s) of the team establish(es) that he or she/they bear(s) *No Fault* or *Negligence* for that violation, the results of the team in any other *Competition(s)* in that *Event* shall not be *Disqualified* unless the results of the team in the *Competition(s)* other than the *Competition* in which the anti-doping rule violation occurred were likely to have been affected by the *Athlete's* anti-doping rule violation.

ARTICLE 12 SANCTIONS BY the UIM AGAINST OTHER SPORTING BODIES

When the UIM becomes aware that a *National Authority* or any other sporting body over which it has authority has failed to comply with, implement, uphold, and enforce these Anti-Doping Rules within that organization's or body's area of competence, the UIM has the authority and may take the following additional disciplinary actions:

12.1 Exclude all, or some group of, members of that organization or body from specified future *Events* or all *Events* conducted within a specified period of time.

12.2 Take additional disciplinary actions with respect to that organization's or body's recognition, the eligibility of their members to participate in the UIM's activities, and/or fine that organization or body based on the following:

- 12.2.1** Four (4) or more violations of these Anti-Doping Rules (other than violations involving Article 2.4) are committed by *Athletes* or other *Persons* affiliated with that organization or body during a twelve (12) month period. In such event: (a) all or some group of members of that organization or body may be banned from participation in any the UIM activities for a period of up to two (2) years and/or (b) that organization or body may be fined in an amount up to 5'000 Euros.
- 12.2.2** Four (4) or more violations of these Anti-Doping Rules (other than violations involving Article 2.4) are committed in addition to the violations described in Article 12.2.1 by *Athletes* or other *Persons* affiliated with that organization or body during a twelve (12) month period. In such event, that organization or body may be suspended for a period of up to four (4) years.
- 12.2.3** More than one *Athlete* or other *Person* affiliated with that organization or body commits an anti-doping rule violation during an *International Event*. In such event, that organization or body may be fined in an amount up to 5'000 Euros.
- 12.2.4** That organization or body has failed to make diligent efforts to keep the UIM informed about an *Athlete's* whereabouts after receiving a request for that information from the UIM. In such event, that organization or body may be fined in an amount up to 1'000 Euros per *Athlete*, in addition to reimbursement of all of the UIM costs incurred in *Testing* that organization's or body's *Athletes*.

12.3 Withhold some or all funding or other financial and non-financial support to that organization or body.

12.4 Oblige that organization or body to reimburse the UIM for all costs (including but not limited to laboratory fees, hearing expenses and travel) related to a violation of these Anti-Doping Rules committed by an *Athlete* or other *Person* affiliated with that organization or body.

ARTICLE 13 RESULTS MANAGEMENT: APPEALS⁶¹

13.1 Decisions Subject to Appeal

Decisions made under the *Code* or these Anti-Doping Rules may be appealed as set forth below in Articles 13.2 through 13.7 or as otherwise provided in these Anti-Doping Rules, the *Code* or the *International Standards*. Such decisions shall remain in effect while under appeal unless the appellate body orders otherwise.

13.1.1 Scope of Review Not Limited

The scope of review on appeal includes all issues relevant to the matter and is expressly not limited to the issues or scope of review before the initial decision maker. Any party to the appeal may submit evidence, legal arguments and claims that were not raised in the first instance hearing so long as they arise from the same cause of action or same general facts or circumstances raised or addressed in the first instance hearing.⁶²

13.1.2 CAS Shall Not Defer to the Findings Being Appealed

In making its decision, CAS shall not give deference to the discretion exercised by the body whose decision is being appealed.⁶³

⁶¹ [Comment to Article 13: The object of the Code is to have anti-doping matters resolved through fair and transparent internal processes with a final appeal. Anti-doping decisions by Anti-Doping Organizations are made transparent in Article 14. Specified Persons and organizations, including WADA, are then given the opportunity to appeal those decisions. Note that the definition of interested Persons and organizations with a right to appeal under Article 13 does not include Athletes, or their federations, who might benefit from having another competitor Disqualified.]

⁶² [Comment to Article 13.1.1: The revised language is not intended to make a substantive change to the 2015 Code, but rather for clarification. For example, where an Athlete was charged in the first instance hearing only with Tampering but the same conduct could also constitute Complicity, an appealing party could pursue both Tampering and Complicity charges against the Athlete in the appeal.]

⁶³ [Comment to Article 13.1.2: CAS proceedings are de novo. Prior proceedings do not limit the evidence or carry weight in the hearing before

13.1.3 WADA Not Required to Exhaust Internal Remedies

Where WADA has a right to appeal under Article 13 and no other party has appealed a final decision within the UIM's process, WADA may appeal such decision directly to CAS without having to exhaust other remedies in the UIM's process.⁶⁴

13.2 Appeals from Decisions Regarding Anti-Doping Rule Violations, Consequences, Provisional Suspensions, Implementation of Decisions and Authority

A decision that an anti-doping rule violation was committed, a decision imposing *Consequences* or not imposing *Consequences* for an anti-doping rule violation, or a decision that no anti-doping rule violation was committed; a decision that an anti-doping rule violation proceeding cannot go forward for procedural reasons (including, for example, prescription); a decision by WADA not to grant an exception to the six (6) months notice requirement for a retired *Athlete* to return to competition under Article 5.6.1; a decision by WADA assigning *Results Management* under Article 7.1 of the *Code*; a decision by the UIM not to bring forward an *Adverse Analytical Finding* or an *Atypical Finding* as an anti-doping rule violation, or a decision not to go forward with an anti-doping rule violation after an investigation in accordance with the *International Standard for Results Management*; a decision to impose, or lift, a *Provisional Suspension* as a result of a *Provisional Hearing*; the UIM's failure to comply with Article 7.4; a decision that the UIM lacks authority to rule on an alleged anti-doping rule violation or its *Consequences*; a decision to suspend, or not suspend, *Consequences* or to reinstate, or not reinstate, *Consequences* under Article 10.7.1; failure to comply with Articles 7.1.4 and 7.1.5 of the *Code*; failure to comply with Article 10.8.1; a decision under Article 10.14.3; a decision by the UIM not to implement another *Anti-Doping Organization's* decision under Article 15; and a decision under Article 27.3 of the *Code* may be appealed exclusively as provided in this Article 13.2.

13.2.1 Appeals Involving *International-Level Athletes* or *International Events*

In cases arising from participation in an *International Event* or in cases involving *International-Level Athletes*, the decision may be appealed exclusively to CAS.⁶⁵

13.2.2 Appeals Involving Other *Athletes* or Other *Persons*

In cases where Article 13.2.1 is not applicable, the decision may be appealed to an appellate body, in accordance with rules adopted by the *National Anti-Doping Organization* having authority over the *Athlete* or other *Person*.

The rules for such appeal shall respect the following principles: a timely hearing; a fair, impartial, *Operationally Independent* and *Institutionally Independent* hearing panel; the right to be represented by counsel at the *Person's* own expense; and a timely, written, reasoned decision.

If no such body as described above is in place and available at the time of the appeal, the decision may be appealed to CAS in accordance with the applicable procedural rules.

13.2.3 *Persons* Entitled to Appeal

13.2.3.1 Appeals Involving *International-Level Athletes* or *International Events*

In cases under Article 13.2.1, the following parties shall have the right to appeal to CAS: (a) the *Athlete* or other *Person* who is the subject of the decision being appealed; (b) the other party to the case in which the decision was rendered; (c) the UIM; (d) the *National Anti-Doping Organization* of the *Person's* country of residence or countries where the *Person* is a national or license holder; (e) the International Olympic Committee or International Paralympic Committee, as applicable, where the decision may have an effect in relation to the Olympic Games or Paralympic Games, including decisions affecting eligibility for the Olympic Games or Paralympic Games; and (f) WADA.

CAS.]

⁶⁴ [Comment to Article 13.1.3: Where a decision has been rendered before the final stage of the UIM's process (for example, a first hearing) and no party elects to appeal that decision to the next level of the UIM's process (e.g., the Managing Board), then WADA may bypass the remaining steps in the UIM's internal process and appeal directly to CAS.]

⁶⁵ [Comment to Article 13.2.1: CAS decisions are final and binding except for any review required by law applicable to the annulment or enforcement of arbitral awards.]

13.2.3.2 Appeals Involving Other *Athletes* or Other *Persons*

In cases under Article 13.2.2, the parties having the right to appeal to the national-level appeal body shall be as provided in the *National Anti-Doping Organization's* rules but, at a minimum, shall include the following parties: (a) the *Athlete* or other *Person* who is the subject of the decision being appealed; (b) the other party to the case in which the decision was rendered; (c) the UIM; (d) the *National Anti-Doping Organization* of the *Person's* country of residence or countries where the *Person* is a national or license holder; (e) the International Olympic Committee or International Paralympic Committee, as applicable, where the decision may have an effect in relation to the Olympic Games or Paralympic Games, including decisions affecting eligibility for the Olympic Games or Paralympic Games; and (f) *WADA*.

For cases under Article 13.2.2, *WADA*, the International Olympic Committee, the International Paralympic Committee, and the UIM shall also have the right to appeal to CAS with respect to the decision of the national-level appeal body.

Any party filing an appeal shall be entitled to assistance from CAS to obtain all relevant information from the *Anti-Doping Organization* whose decision is being appealed and the information shall be provided if CAS so directs.

13.2.3.3 Duty to Notify

All parties to any CAS appeal must ensure that *WADA* and all other parties with a right to appeal have been given timely notice of the appeal.

13.2.3.4 Appeal from Imposition of *Provisional Suspension*

Notwithstanding any other provision herein, the only *Person* who may appeal from the imposition of a *Provisional Suspension* is the *Athlete* or other *Person* upon whom the *Provisional Suspension* is imposed.

13.2.3.5 Appeal from Decisions under Article 12

Decisions by the UIM pursuant to Article 12 may be appealed exclusively to CAS by the *National Authority* or other body.

13.2.4 Cross Appeals and other Subsequent Appeals Allowed

Cross appeals and other subsequent appeals by any respondent named in cases brought to CAS under the *Code* are specifically permitted. Any party with a right to appeal under this Article 13 must file a cross appeal or subsequent appeal at the latest with the party's answer.⁶⁶

13.3 Failure to Render a Timely Decision by the UIM

Where, in a particular case, the UIM fails to render a decision with respect to whether an anti-doping rule violation was committed within a reasonable deadline set by *WADA*, *WADA* may elect to appeal directly to CAS as if the UIM had rendered a decision finding no anti-doping rule violation. If the CAS hearing panel determines that an anti-doping rule violation was committed and that *WADA* acted reasonably in electing to appeal directly to CAS, then *WADA's* costs and attorney fees in prosecuting the appeal shall be reimbursed to *WADA* by the UIM.⁶⁷

⁶⁶ [Comment to Article 13.2.4: This provision is necessary because since 2011, CAS rules no longer permit an *Athlete* the right to cross appeal when an *Anti-Doping Organization* appeals a decision after the *Athlete's* time for appeal has expired. This provision permits a full hearing for all parties.]

⁶⁷ [Comment to Article 13.3: Given the different circumstances of each anti-doping rule violation investigation and Results Management process, it is not feasible to establish a fixed time period for the UIM to render a decision before *WADA* may intervene by appealing directly to CAS. Before taking such action, however, *WADA* will consult with the UIM and give the UIM an opportunity to explain why it has not yet rendered a decision.]

13.4 Appeals Relating to *TUEs*

TUE decisions may be appealed exclusively as provided in Article 4.4.

13.5 Notification of Appeal Decisions

The UIM shall promptly provide the appeal decision to the *Athlete* or other *Person* and to the other *Anti-Doping Organizations* that would have been entitled to appeal under Article 13.2.3 as provided under Article 14.2.

13.6 Time for Filing Appeals⁶⁸

13.6.1 Appeals to CAS

The time to file an appeal to CAS shall be twenty-one (21) days from the date of receipt of the decision by the appealing party. The above notwithstanding, the following shall apply in connection with appeals filed by a party entitled to appeal but which was not a party to the proceedings that led to the decision being appealed:

- (a) Within fifteen (15) days from the notice of the decision, such party/ies shall have the right to request a copy of the full case file pertaining to the decision from the *Anti-Doping Organization* that had *Results Management* authority;
- (b) If such a request is made within the fifteen (15) day period, then the party making such request shall have twenty-one (21) days from receipt of the file to file an appeal to CAS.

The above notwithstanding, the filing deadline for an appeal filed by WADA shall be the later of:

- (a) Twenty-one (21) days after the last day on which any other party having a right to appeal could have appealed, or
- (b) Twenty-one (21) days after WADA's receipt of the complete file relating to the decision.

13.6.2 Appeals Under Article 13.2.2

The time to file an appeal to an independent and impartial body in accordance with rules established by the *National Anti-Doping Organization* shall be indicated by the same rules of the *National Anti-Doping Organization*.

The above notwithstanding, the filing deadline for an appeal filed by WADA shall be the later of:

- (a) Twenty-one (21) days after the last day on which any other party having a right to appeal could have appealed, or
- (b) Twenty-one (21) days after WADA's receipt of the complete file relating to the decision.

ARTICLE 14 CONFIDENTIALITY AND REPORTING

14.1 Information Concerning *Adverse Analytical Findings*, *Atypical Findings*, and Other Asserted Anti-Doping Rule Violations

14.1.1 Notice of Anti-Doping Rule Violations to *Athletes* and other *Persons*

Notice to *Athletes* or other *Persons* of anti-doping rule violations asserted against them shall occur as provided under Articles 7 and 14.

⁶⁸ [Comment to Article 13.6: Whether governed by CAS rules or these Anti-Doping Rules, a party's deadline to appeal does not begin running until receipt of the decision. For that reason, there can be no expiration of a party's right to appeal if the party has not received the decision.]

If at any point during *Results Management* up until the anti-doping rule violation charge, the UIM decides not to move forward with a matter, it must notify the *Athlete* or other *Person*, (provided that the *Athlete* or other *Person* had been already informed of the ongoing *Results Management*).

Notice shall be delivered or emailed to *Athletes* or other *Persons*. If the notification takes place via the *Athlete* or other *Person's National Authority*, the *National Authority* shall confirm to the UIM that they have received the notification and that the notification has been provided to the *Athlete* or other *Person*.

14.1.2 Notice of Anti-Doping Rule Violations to *National Anti-Doping Organizations* and WADA

Notice of the assertion of an anti-doping rule violation to the *Athlete's* or other *Person's National Anti-Doping Organization* and WADA shall occur as provided under Articles 7 and 14, simultaneously with the notice to the *Athlete* or other *Person*.

If at any point during *Results Management* up until the anti-doping rule violation charge, the UIM decides not to move forward with a matter, it must give notice (with reasons) to the *Anti-Doping Organizations* with a right of appeal under Article 13.2.3.

Notice shall be delivered or emailed.

14.1.3 Content of an Anti-Doping Rule Violation Notice

Notification of an anti-doping rule violation shall include: the *Athlete's* or other *Person's* name, country, sport and discipline within the sport, the *Athlete's* competitive level, whether the test was *In-Competition* or *Out-of-Competition*, the date of *Sample* collection, the analytical result reported by the laboratory, and other information as required by the *International Standard for Testing and Investigations* and *International Standard for Results Management*.

Notification of anti-doping rule violations other than under Article 2.1 shall also include the rule violated and the basis of the asserted violation.

14.1.4 Status Reports

Except with respect to investigations which have not resulted in a notice of an anti-doping rule violation pursuant to Article 14.1.1, the *Athlete's* or other *Person's National Anti-Doping Organization* and WADA shall be regularly updated on the status and findings of any review or proceedings conducted pursuant to Article 7, 8 or 13 and shall be provided with a prompt written reasoned explanation or decision explaining the resolution of the matter.

14.1.5 Confidentiality

The recipient organizations shall not disclose this information beyond those *Persons* with a need to know (which would include the appropriate personnel at the applicable *National Olympic Committee, National Authority*, until the UIM has made *Public Disclosure* as permitted by Article 14.3.

14.1.6 Protection of Confidential Information by an Employee or Agent of the UIM

The UIM shall ensure that information concerning *Adverse Analytical Findings, Atypical Findings*, and other asserted anti-doping rule violations remains confidential until such information is *Publicly Disclosed* in accordance with Article 14.3. the UIM shall ensure that its employees (whether permanent or otherwise), contractors, agents, consultants, and *Delegated Third Parties* are subject to fully enforceable contractual duty of confidentiality and to fully enforceable procedures for the investigation and disciplining of improper and/or unauthorized disclosure of such confidential information.

14.2 Notice of Anti-Doping Rule Violation or Violations of *Ineligibility* or *Provisional Suspension* Decisions and Request for Files

14.2.1 Anti-doping rule violation decisions or decisions related to violations of *Ineligibility* or *Provisional Suspension* rendered pursuant to Article 7.6, 8.2, 10.5, 10.6, 10.7, 10.14.3 or 13.5 shall include the full reasons for the decision, including, if applicable, a justification

for why the maximum potential sanction was not imposed. Where the decision is not in English or French, the UIM shall provide an English or French summary of the decision and the supporting reasons.

- 14.2.2** An *Anti-Doping Organization* having a right to appeal a decision received pursuant to Article 14.2.1 may, within fifteen (15) days of receipt, request a copy of the full case file pertaining to the decision.

14.3 Public Disclosure

- 14.3.1** After notice has been provided to the *Athlete* or other *Person* in accordance with the *International Standard for Results Management*, and to the applicable *Anti-Doping Organizations* in accordance with Article 14.1.2, the identity of any *Athlete* or other *Person* who is notified of a potential anti-doping rule violation, the *Prohibited Substance* or *Prohibited Method* and the nature of the violation involved, and whether the *Athlete* or other *Person* is subject to a *Provisional Suspension* may be *Publicly Disclosed* by the UIM.
- 14.3.2** No later than twenty (20) days after it has been determined in an appellate decision under Article 13.2.1 or 13.2.2, or such appeal has been waived, or a hearing in accordance with Article 8 has been waived, or the assertion of an anti-doping rule violation has not otherwise been timely challenged, or the matter has been resolved under Article 10.8, or a new period of *Ineligibility*, or reprimand, has been imposed under Article 10.14.3, the UIM must *Publicly Disclose* the disposition of the anti-doping matter, including the sport, the anti-doping rule violated, the name of the *Athlete* or other *Person* committing the violation, the *Prohibited Substance* or *Prohibited Method* involved (if any) and the *Consequences* imposed. The UIM must also *Publicly Disclose* within twenty (20) days the results of appellate decisions concerning anti-doping rule violations, including the information described above.⁶⁹
- 14.3.3** After an anti-doping rule violation has been determined to have been committed in an appellate decision under Article 13.2.1 or 13.2.2 or such appeal has been waived, or in a hearing in accordance with Article 8 or where such hearing has been waived, or the assertion of an anti-doping rule violation has not otherwise been timely challenged, or the matter has been resolved under Article 10.8, the UIM may make public such determination or decision and may comment publicly on the matter.
- 14.3.4** In any case where it is determined, after a hearing or appeal, that the *Athlete* or other *Person* did not commit an anti-doping rule violation, the fact that the decision has been appealed may be *Publicly Disclosed*. However, the decision itself and the underlying facts may not be *Publicly Disclosed* except with the consent of the *Athlete* or other *Person* who is the subject of the decision. The UIM shall use reasonable efforts to obtain such consent, and if consent is obtained, shall *Publicly Disclose* the decision in its entirety or in such redacted form as the *Athlete* or other *Person* may approve.
- 14.3.5** Publication shall be accomplished at a minimum by placing the required information on the UIM's website and leaving the information up for the longer of one (1) month or the duration of any period of *Ineligibility*. It will be removed immediately after the expiry of the indicated time periods.
- 14.3.6** Except as provided in Articles 14.3.1 and 14.3.3, no *Anti-Doping Organization*, *National Authority*, or WADA-accredited laboratory, or any official of any such body, shall publicly comment on the specific facts of any pending case (as opposed to general description of process and science) except in response to public comments attributed to, or based on information provided by, the *Athlete*, other *Person* or their entourage or other representatives.
- 14.3.7** The mandatory *Public Disclosure* required in Article 14.3.2 shall not be required where the *Athlete* or other *Person* who has been found to have committed an anti-doping rule

⁶⁹ [Comment to Article 14.3.2: Where Public Disclosure as required by Article 14.3.2 would result in a breach of other applicable laws, the UIM's failure to make the Public Disclosure will not result in a determination of non-compliance with Code as set forth in Article 4.1 of the International Standard for the Protection of Privacy and Personal Information.]

violation is a *Minor, Protected Person* or *Recreational Athlete*. Any optional *Public Disclosure* in a case involving a *Minor, Protected Person* or *Recreational Athlete* shall be proportionate to the facts and circumstances of the case.

14.4 Statistical Reporting

The UIM shall, at least annually, publish publicly a general statistical report of its *Doping Control* activities, with a copy provided to *WADA*. The UIM may also publish reports showing the name of each *Athlete* tested and the date of each *Testing*.

14.5 Doping Control Information Database and Monitoring of Compliance

To enable *WADA* to perform its compliance monitoring role and to ensure the effective use of resources and sharing of applicable *Doping Control* information among *Anti-Doping Organizations*, the UIM shall report to *WADA* through *ADAMS Doping Control*-related information, including, in particular:

- (a) *Athlete Biological Passport* data for *International-Level Athletes* and *National-Level Athletes*,
- (b) Whereabouts information for *Athletes* including those in *Registered Testing Pools*,
- (c) *TUE* decisions, and
- (d) *Results Management* decisions,

as required under the applicable *International Standard(s)*.

- 14.5.1 To facilitate coordinated test distribution planning, avoid unnecessary duplication in *Testing* by various *Anti-Doping Organizations*, and to ensure that *Athlete Biological Passport* profiles are updated, the UIM shall report all *In-Competition* and *Out-of-Competition* tests to *WADA* by entering the *Doping Control* forms into *ADAMS* in accordance with the requirements and timelines contained in the *International Standard* for *Testing* and *Investigations*.
- 14.5.2 To facilitate *WADA's* oversight and appeal rights for *TUEs*, the UIM shall report all *TUE* applications, decisions and supporting documentation using *ADAMS* in accordance with the requirements and timelines contained in the *International Standard* for *Therapeutic Use Exemptions*.
- 14.5.3 To facilitate *WADA's* oversight and appeal rights for *Results Management*, the UIM shall report the following information into *ADAMS* in accordance with the requirements and timelines outlined in the *International Standard* for *Results Management*: (a) notifications of anti-doping rule violations and related decisions for *Adverse Analytical Findings*; (b) notifications and related decisions for other anti-doping rule violations that are not *Adverse Analytical Findings*; (c) whereabouts failures; and (d) any decision imposing, lifting or reinstating a *Provisional Suspension*.
- 14.5.4 The information described in this Article will be made accessible, where appropriate and in accordance with the applicable rules, to the *Athlete*, the *Athlete's National Anti-Doping Organization*, and any other *Anti-Doping Organizations* with *Testing* authority over the *Athlete*.

14.6 Data Privacy

- 14.6.1 The UIM may collect, store, process or disclose personal information relating to *Athletes* and other *Persons* where necessary and appropriate to conduct its *Anti-Doping Activities* under the *Code*, the *International Standards* (including specifically the *International Standard* for the Protection of Privacy and Personal Information), these *Anti-Doping Rules*, and in compliance with applicable law.
- 14.6.2 Without limiting the foregoing, the UIM shall:
 - (a) Only process personal information in accordance with a valid legal ground;
 - (b) Notify any *Participant* or *Person* subject to these *Anti-Doping Rules*, in a manner and form that complies with applicable laws and the *International Standard* for the Protection of Privacy and Personal Information, that their personal information may

be processed by the UIM and other *Persons* for the purpose of the implementation of these Anti-Doping Rules;

- (c) Ensure that any third-party agents (including any *Delegated Third Party*) with whom the UIM shares the personal information of any *Participant* or *Person* is subject to appropriate technical and contractual controls to protect the confidentiality and privacy of such information.

ARTICLE 15 IMPLEMENTATION OF DECISIONS

15.1 Automatic Binding Effect of Decisions by *Signatory Anti-Doping Organizations*

- 15.1.1** A decision of an anti-doping rule violation made by a *Signatory Anti-Doping Organization*, an appellate body (Article 13.2.2 of the *Code*) or CAS shall, after the parties to the proceeding are notified, automatically be binding beyond the parties to the proceeding upon the UIM and its *National Authorities*, as well as every *Signatory* in every sport with the effects described below:
- 15.1.1.1** A decision by any of the above-described bodies imposing a *Provisional Suspension* (after a *Provisional Hearing* has occurred or the *Athlete* or other *Person* has either accepted the *Provisional Suspension* or has waived the right to a *Provisional Hearing*, expedited hearing or expedited appeal offered in accordance with Article 7.4.3) automatically prohibits the *Athlete* or other *Person* from participation (as described in Article 10.14.1) in all sports within the authority of any *Signatory* during the *Provisional Suspension*.
- 15.1.1.2** A decision by any of the above-described bodies imposing a period of *Ineligibility* (after a hearing has occurred or been waived) automatically prohibits the *Athlete* or other *Person* from participation (as described in Article 10.14.1) in all sports within the authority of any *Signatory* for the period of *Ineligibility*.
- 15.1.1.3** A decision by any of the above-described bodies accepting an anti-doping rule violation automatically binds all *Signatories*.
- 15.1.1.4** A decision by any of the above-described bodies to *Disqualify* results under Article 10.10 for a specified period automatically *Disqualifies* all results obtained within the authority of any *Signatory* during the specified period.
- 15.1.2** The UIM and its *National Authorities* shall recognize and implement a decision and its effects as required by Article 15.1.1, without any further action required, on the earlier of the date the UIM receives actual notice of the decision or the date the decision is placed into ADAMS.
- 15.1.3** A decision by an *Anti-Doping Organization*, a national appellate body or CAS to suspend, or lift, *Consequences* shall be binding upon the UIM and its *National Authorities* without any further action required, on the earlier of the date the UIM receives actual notice of the decision or the date the decision is placed into ADAMS.
- 15.1.4** Notwithstanding any provision in Article 15.1.1, however, a decision of an anti-doping rule violation by a *Major Event Organization* made in an expedited process during an *Event* shall not be binding on the UIM or its *National Authorities* unless the rules of the *Major Event Organization* provide the *Athlete* or other *Person* with an opportunity to an appeal under non-expedited procedures.⁷⁰

15.2 Implementation of Other Decisions by *Anti-Doping Organizations*

⁷⁰ [Comment to Article 15.1.4: By way of example, where the rules of the *Major Event Organization* give the *Athlete* or other *Person* the option of choosing an expedited CAS appeal or a CAS appeal under normal CAS procedure, the final decision or adjudication by the *Major Event Organization* is binding on other *Signatories* regardless of whether the *Athlete* or other *Person* chooses the expedited appeal option.]

The UIM and its *National Authorities* may decide to implement other anti-doping decisions rendered by *Anti-Doping Organizations* not described in Article 15.1.1 above, such as a *Provisional Suspension* prior to a *Provisional Hearing* or acceptance by the *Athlete* or other *Person*.⁷¹

15.3 Implementation of Decisions by Body that is not a Signatory

An anti-doping decision by a body that is not a *Signatory* to the *Code* shall be implemented by the UIM and its *National Authorities*, if the UIM finds that the decision purports to be within the authority of that body and the anti-doping rules of that body are otherwise consistent with the *Code*.⁷²

ARTICLE 16 STATUTE OF LIMITATIONS

No anti-doping rule violation proceeding may be commenced against an *Athlete* or other *Person* unless he or she has been notified of the anti-doping rule violation as provided in Article 7, or notification has been reasonably attempted, within ten (10) years from the date the violation is asserted to have occurred.

ARTICLE 17 EDUCATION

The UIM shall plan, implement, evaluate and promote *Education* in line with the requirements of Article 18.2 of the *Code* and the *International Standard for Education*.

The UIM may decide to request that *Athletes* complete *Educational* activities before and/or during their participation in select *Events* (e.g.: Youth World Championships) as a condition of such participation. The list of *Events* for which *Athletes* will be required to complete *Educational* activities as a condition of participation will be published on the UIM's website.

Failure by the *Athlete* to complete *Educational* activities as requested by the UIM may result in the imposition of sanction under the UIM's disciplinary rules, unless the *Athlete* provides to the UIM a justification for such failure, which shall be assessed by the UIM on a case by case basis.

ARTICLE 18 ADDITIONAL ROLES AND RESPONSIBILITIES OF NATIONAL AUTHORITIES

18.1 All *National Authorities* and their members shall comply with the *Code*, *International Standards*, and these Anti-Doping Rules. All *National Authorities* and other members shall include in their policies, rules and programs the provisions necessary to ensure that the UIM may enforce these Anti-Doping Rules (including carrying out *Testing*) directly in respect of *Athletes* (including *National-Level Athletes*) and other *Persons* under their anti-doping authority as specified in the Introduction to these Anti-Doping Rules (Section "Scope of these Anti-Doping Rules").

18.2 Each *National Authority* shall incorporate these Anti-Doping Rules either directly or by reference into its governing documents, constitution and/or rules as part of the rules of sport that bind their

⁷¹ [Comment to Articles 15.1 and 15.2: Anti-Doping Organization decisions under Article 15.1 are implemented automatically by other Signatories without the requirement of any decision or further action on the Signatories' part. For example, when a National Anti-Doping Organization decides to Provisionally Suspend an Athlete, that decision is given automatic effect at the International Federation level. To be clear, the "decision" is the one made by the National Anti-Doping Organization, there is not a separate decision to be made by the International Federation. Thus, any claim by the Athlete that the Provisional Suspension was improperly imposed can only be asserted against the National Anti-Doping Organization. Implementation of Anti-Doping Organizations' decisions under Article 15.2 is subject to each Signatory's discretion. A Signatory's implementation of a decision under Article 15.1 or Article 15.2 is not appealable separately from any appeal of the underlying decision. The extent of recognition of TUE decisions of other Anti-Doping Organizations shall be determined by Article 4.4 and the International Standard for Therapeutic Use Exemptions.]

⁷² [Comment to Article 15.3: Where the decision of a body that has not accepted the Code is in some respects Code compliant and in other respects not Code compliant, the UIM, other Signatories and National Authorities should attempt to apply the decision in harmony with the principles of the Code. For example, if in a process consistent with the Code a non-Signatory has found an Athlete to have committed an anti-doping rule violation on account of the presence of a Prohibited Substance in the Athlete's body but the period of Ineligibility applied is shorter than the period provided for in the Code, then the UIM and all other Signatories should recognize the finding of an anti-doping rule violation and the Athlete's National Anti-Doping Organization should conduct a hearing consistent with Article 8 to determine whether the longer period of Ineligibility provided in the Code should be imposed. the UIM or other Signatory's implementation of a decision, or their decision not to implement a decision under Article 15.3, is appealable under Article 13.]

members so that the *National Authority* may enforce them itself directly in respect of *Athletes* (including *National-Level Athletes*) and other *Persons* under its anti-doping authority.

- 18.3** By adopting these Anti-Doping Rules, and incorporating them into their governing documents and rules of sport, *National Authorities* shall cooperate with and support the UIM in that function. They shall also recognize, abide by and implement the decisions made pursuant to these Anti-Doping Rules, including the decisions imposing sanctions on *Persons* under their authority.
- 18.4** All *National Authorities* shall take appropriate action to enforce compliance with the *Code*, *International Standards*, and these Anti-Doping Rules by *inter alia*:
- (i) conducting *Testing* only under the documented authority of the UIM and using their *National Anti-Doping Organization* or other *Sample* collection authority to collect *Samples* in compliance with the *International Standard for Testing and Investigations*;
 - (ii) recognizing the authority of the *National Anti-Doping Organization* in their country in accordance with Article 5.2.1 of the *Code* and assisting as appropriate with the *National Anti-Doping Organization's* implementation of the national *Testing* program for their sport;
 - (iii) analysing all *Samples* collected using a *WADA*-accredited or *WADA*-approved laboratory in accordance with Article 6.1; and
 - (iv) ensuring that any national level anti-doping rule violation cases discovered by *National Authorities* are adjudicated by an *Operationally Independent* hearing panel in accordance with Article 8.1 and the *International Standard for Results Management*.
- 18.5** All *National Authorities* shall establish rules requiring all *Athletes* preparing for or participating in a *Competition* or activity authorized or organized by a *National Authority* or one of its member organizations, and all *Athlete Support Personnel* associated with such *Athletes*, to agree to be bound by these Anti-Doping Rules and to submit to the *Results Management* authority of the *Anti-Doping Organization* in conformity with the *Code* as a condition of such participation.
- 18.6** All *National Authorities* shall report any information suggesting or relating to an anti-doping rule violation to the UIM and to their *National Anti-Doping Organizations* and shall cooperate with investigations conducted by any *Anti-Doping Organization* with authority to conduct the investigation.
- 18.7** All *National Authorities* shall have disciplinary rules in place to prevent *Athlete Support Personnel* who are *Using Prohibited Substances* or *Prohibited Methods* without valid justification from providing support to *Athletes* under the authority of the UIM or the *National Authority*.
- 18.8** All *National Authorities* shall conduct anti-doping *Education* in coordination with their *National Anti-Doping Organizations*.

ARTICLE 19 **ADDITIONAL Roles and responsibilities OF the UIM**

- 19.1** In addition to the roles and responsibilities described in Article 20.3 of the *Code* for International Federations the UIM shall report to *WADA* on the UIM's compliance with the *Code* and the *International Standards* in accordance with Article 24.1.2 of the *Code*.
- 19.2** Subject to applicable law, and in accordance with Article 20.3.4 of the *Code*, all the UIM board members, directors, officers, employees and those of appointed *Delegated Third Parties* who are involved in any aspect of *Doping Control*, must sign a form provided by the UIM, agreeing to be bound by these Anti-Doping Rules as *Persons* in conformity with the *Code* for direct and intentional misconduct.
- 19.3** Subject to applicable law, and in accordance with Article 20.3.5 of the *Code*, any the UIM employee who is involved in *Doping Control* (other than authorized anti-doping *Education* or rehabilitation programs) must sign a statement provided by the UIM confirming that they are not *Provisionally Suspended* or serving a period of *Ineligibility* and have not been directly or intentionally engaged in

conduct within the previous six (6) years which would have constituted a violation of anti-doping rules if *Code*-compliant rules had been applicable to them.

ARTICLE 20 ADDITIONAL ROLES AND RESPONSIBILITIES OF *ATHLETES*

- 20.1** To be knowledgeable of and comply with these Anti-Doping Rules.
- 20.2** To be available for *Sample* collection at all times.⁷³
- 20.3** To take responsibility, in the context of anti-doping, for what they ingest and *Use*.
- 20.4** To inform medical personnel of their obligation not to *Use Prohibited Substances* and *Prohibited Methods* and to take responsibility to make sure that any medical treatment received does not violate these Anti-Doping Rules.
- 20.5** To disclose to the UIM and their *National Anti-Doping Organization* any decision by a non-*Signatory* finding that the *Athlete* committed an anti-doping rule violation within the previous ten (10) years.
- 20.6** To cooperate with *Anti-Doping Organizations* investigating anti-doping rule violations.
Failure by any *Athlete* to cooperate in full with *Anti-Doping Organizations* investigating anti-doping rule violations may result in a charge of misconduct under the UIM's disciplinary rules.
- 20.7** To disclose the identity of their *Athlete Support Personnel* upon request by the UIM or a *National Authority*, or any other *Anti-Doping Organization* with authority over the *Athlete*.
- 20.8** Offensive conduct towards a *Doping Control* official or other *Person* involved in *Doping Control* by an *Athlete*, which does not otherwise constitute *Tampering*, may result in a charge of misconduct under the UIM's disciplinary rules.

ARTICLE 21 ADDITIONAL ROLES AND RESPONSIBILITIES OF *ATHLETE SUPPORT PERSONNEL*

- 21.1** To be knowledgeable of and comply with these Anti-Doping Rules.
- 21.2** To cooperate with the *Athlete Testing* program.
- 21.3** To use their influence on *Athlete* values and behavior to foster anti-doping attitudes.
- 21.4** To disclose to the UIM and their *National Anti-Doping Organization* any decision by a non-*Signatory* finding that they committed an anti-doping rule violation within the previous ten (10) years.
- 21.5** To cooperate with *Anti-Doping Organizations* investigating anti-doping rule violations.
Failure by any *Athlete Support Personnel* to cooperate in full with *Anti-Doping Organizations* investigating anti-doping rule violations may result in a charge of misconduct under the UIM's disciplinary rules.
- 21.6** *Athlete Support Personnel* shall not *Use* or *Possess* any *Prohibited Substance* or *Prohibited Method* without valid justification.
Any such *Use* or *Possession* may result in a charge of misconduct under the UIM's disciplinary rules.
- 21.7** Offensive conduct towards a *Doping Control* official or other *Person* involved in *Doping Control* by *Athlete Support Personnel*, which does not otherwise constitute *Tampering*, may result in a charge of misconduct under the UIM's disciplinary rules.

⁷³ [Comment to Article 20.2: With due regard to an *Athlete's* human rights and privacy, legitimate anti-doping considerations sometimes require *Sample* collection late at night or early in the morning. For example, it is known that some *Athletes* *Use* low doses of *EPO* during these hours so that it will be undetectable in the morning.]

ARTICLE 22 ADDITIONAL ROLES AND RESPONSIBILITIES OF OTHER PERSONS SUBJECT TO THESE ANTI-DOPING RULES

- 22.1** To be knowledgeable of and comply with these Anti-Doping Rules.
- 22.2** To disclose to the UIM and their *National Anti-Doping Organization* any decision by a non-*Signatory* finding that they committed an anti-doping rule violation within the previous ten (10) years.
- 22.3** To cooperate with *Anti-Doping Organizations* investigating anti-doping rule violations.
- Failure by any other *Person* subject to these Anti-Doping Rules to cooperate in full with *Anti-Doping Organizations* investigating anti-doping rule violations may result in a charge of misconduct under the UIM's disciplinary rules.
- 22.4** Not to *Use* or *Possess* any *Prohibited Substance* or *Prohibited Method* without valid justification.
- 22.5** Offensive conduct towards a *Doping Control* official or other *Person* involved in *Doping Control* by a *Person*, which does not otherwise constitute *Tampering*, may result in a charge of misconduct under the UIM's disciplinary rules.

ARTICLE 23 INTERPRETATION OF THE CODE

- 23.1** The official text of the *Code* shall be maintained by WADA and shall be published in English and French. In the event of any conflict between the English and French versions, the English version shall prevail.
- 23.2** The comments annotating various provisions of the *Code* shall be used to interpret the *Code*.
- 23.3** The *Code* shall be interpreted as an independent and autonomous text and not by reference to the existing law or statutes of the *Signatories* or governments.
- 23.4** The headings used for the various Parts and Articles of the *Code* are for convenience only and shall not be deemed part of the substance of the *Code* or to affect in any way the language of the provisions to which they refer.
- 23.5** Where the term "days" is used in the *Code* or an *International Standard*, it shall mean calendar days unless otherwise specified.
- 23.6** The *Code* shall not apply retroactively to matters pending before the date the *Code* is accepted by a *Signatory* and implemented in its rules. However, pre-*Code* anti-doping rule violations would continue to count as "First violations" or "Second violations" for purposes of determining sanctions under Article 10 for subsequent post-*Code* violations.
- 23.7** The Purpose, Scope and Organization of the World Anti-Doping Program and the *Code* and Appendix 1, Definitions, and Appendix 2, Examples of the Application of Article 10, shall be considered integral parts of the *Code*.

ARTICLE 24 FINAL PROVISIONS

- 24.1** Where the term "days" is used in these Anti-Doping Rules, it shall mean calendar days unless otherwise specified.
- 24.2** These Anti-Doping Rules shall be interpreted as an independent and autonomous text and not by reference to existing law or statutes.
- 24.3** These Anti-Doping Rules have been adopted pursuant to the applicable provisions of the *Code* and the *International Standards* and shall be interpreted in a manner that is consistent with applicable provisions of the *Code* and the *International Standards*. The *Code* and the *International Standards* shall be considered integral parts of these Anti-Doping Rules and shall prevail in case of conflict.
- 24.4** The Introduction and Appendix 1 shall be considered integral parts of these Anti-Doping Rules.

- 24.5** The comments annotating various provisions of these Anti-Doping Rules shall be used to interpret these Anti-Doping Rules.
- 24.6** These Anti-Doping Rules entered into force on 1 January 2024 (the “Effective Date”). They repeal previous versions of the UIM’s Anti-Doping Rules.
- 24.7** These Anti-Doping Rules shall not apply retroactively to matters pending before the Effective Date. However:
- 24.7.1** Anti-doping rule violations taking place prior to the Effective Date count as “first violations” or “second violations” for purposes of determining sanctions under Article 10 for violations taking place after the Effective Date.
- 24.7.2** Any anti-doping rule violation case which is pending as of the Effective Date and any anti-doping rule violation case brought after the Effective Date based on an anti-doping rule violation which occurred prior to the Effective Date, shall be governed by the substantive anti-doping rules in effect at the time the alleged anti-doping rule violation occurred, and not by the substantive anti-doping rules set out in these Anti-Doping Rules, unless the panel hearing the case determines the principle of “lex mitior” appropriately applies under the circumstances of the case. For these purposes, the retrospective periods in which prior violations can be considered for purposes of multiple violations under Article 10.9.4 and the statute of limitations set forth in Article 16 are procedural rules, not substantive rules, and should be applied retroactively along with all of the other procedural rules in these Anti-Doping Rules (provided, however, that Article 16 shall only be applied retroactively if the statute of limitation period has not already expired by the Effective Date).
- 24.7.3** Any Article 2.4 whereabouts failure (whether a filing failure or a missed test, as those terms are defined in the *International Standard for Results Management*) prior to the Effective Date shall be carried forward and may be relied upon, prior to expiry, in accordance with the *International Standard for Results Management*, but it shall be deemed to have expired twelve (12) months after it occurred.
- 24.7.4** With respect to cases where a final decision finding an anti-doping rule violation has been rendered prior to the Effective Date, but the *Athlete* or other *Person* is still serving the period of *Ineligibility* as of the Effective Date, the *Athlete* or other *Person* may apply to the UIM or other *Anti-Doping Organization* which had *Results Management* responsibility for the anti-doping rule violation to consider a reduction in the period of *Ineligibility* in light of these Anti-Doping Rules. Such application must be made before the period of *Ineligibility* has expired. The decision rendered may be appealed pursuant to Article 13.2. These Anti-Doping Rules shall have no application to any case where a final decision finding an anti-doping rule violation has been rendered and the period of *Ineligibility* has expired.
- 24.7.5** For purposes of assessing the period of *Ineligibility* for a second violation under Article 10.9.1, where the sanction for the first violation was determined based on rules in force prior to the Effective Date, the period of *Ineligibility* which would have been assessed for that first violation had these Anti-Doping Rules been applicable, shall be applied.⁷⁴
- 24.7.6** Changes to the *Prohibited List* and *Technical Documents* relating to substances or methods on the *Prohibited List* shall not, unless they specifically provide otherwise, be applied retroactively. As an exception, however, when a *Prohibited Substance* or *Prohibited Method* has been removed from the *Prohibited List*, an *Athlete* or other *Person* currently serving a period of *Ineligibility* on account of the formerly *Prohibited Substance* or *Prohibited Method* may apply to the UIM or other *Anti-Doping Organization* which had *Results Management* responsibility for the anti-doping rule violation to consider a reduction in the period of *Ineligibility* in light of the removal of the substance or method from the *Prohibited List*.

⁷⁴ [Comment to Article 24.7.5: Other than the situation described in Article 24.7.5, where a final decision finding an anti-doping rule violation has been rendered prior to the Effective Date and the period of *Ineligibility* imposed has been completely served, these Anti-Doping Rules may not be used to re-characterize the prior violation.]

APPENDIX 1 DEFINITIONS

ADAMS: The Anti-Doping Administration and Management System is a Web-based database management tool for data entry, storage, sharing, and reporting designed to assist stakeholders and WADA in their anti-doping operations in conjunction with data protection legislation.

Administration: Providing, supplying, supervising, facilitating, or otherwise participating in the *Use* or *Attempted Use* by another *Person* of a *Prohibited Substance* or *Prohibited Method*. However, this definition shall not include the actions of bona fide medical personnel involving a *Prohibited Substance* or *Prohibited Method* Used for genuine and legal therapeutic purposes or other acceptable justification and shall not include actions involving *Prohibited Substances* which are not prohibited in *Out-of-Competition Testing* unless the circumstances as a whole demonstrate that such *Prohibited Substances* are not intended for genuine and legal therapeutic purposes or are intended to enhance sport performance.

Adverse Analytical Finding: A report from a WADA-accredited laboratory or other WADA-approved laboratory that, consistent with the *International Standard* for Laboratories, establishes in a *Sample* the presence of a *Prohibited Substance* or its *Metabolites* or *Markers* or evidence of the *Use* of a *Prohibited Method*.

Adverse Passport Finding: A report identified as an *Adverse Passport Finding* as described in the applicable *International Standards*.

Aggravating Circumstances: Circumstances involving, or actions by, an *Athlete* or other *Person* which may justify the imposition of a period of *Ineligibility* greater than the standard sanction. Such circumstances and actions shall include, but are not limited to: the *Athlete* or other *Person* Used or Possessed multiple *Prohibited Substances* or *Prohibited Methods*, Used or Possessed a *Prohibited Substance* or *Prohibited Method* on multiple occasions or committed multiple other anti-doping rule violations; a normal individual would be likely to enjoy the performance-enhancing effects of the anti-doping rule violation(s) beyond the otherwise applicable period of *Ineligibility*; the *Athlete* or *Person* engaged in deceptive or obstructive conduct to avoid the detection or adjudication of an anti-doping rule violation; or the *Athlete* or other *Person* engaged in *Tampering* during *Results Management*. For the avoidance of doubt, the examples of circumstances and conduct described herein are not exclusive and other similar circumstances or conduct may also justify the imposition of a longer period of *Ineligibility*.

Anti-Doping Activities: Anti-doping *Education* and information, test distribution planning, maintenance of a *Registered Testing Pool*, managing *Athlete Biological Passports*, conducting *Testing*, organizing analysis of *Samples*, gathering of intelligence and conduct of investigations, processing of *TUE* applications, *Results Management*, monitoring and enforcing compliance with any *Consequences* imposed, and all other activities related to anti-doping to be carried out by or on behalf of an *Anti-Doping Organization*, as set out in the *Code* and/or the *International Standards*.

Anti-Doping Organization: WADA or a *Signatory* that is responsible for adopting rules for initiating, implementing or enforcing any part of the *Doping Control* process. This includes, for example, the International Olympic Committee, the International Paralympic Committee, other *Major Event Organizations* that conduct *Testing* at their *Events*, International Federations, and *National Anti-Doping Organizations*.

Athlete: Any *Person* who competes in sport at the international level (as defined by each International Federation) or the national level (as defined by each *National Anti-Doping Organization*). An *Anti-Doping Organization* has discretion to apply anti-doping rules to an *Athlete* who is neither an *International-Level Athlete* nor a *National-Level Athlete*, and thus to bring them within the definition of “*Athlete*”. In relation to *Athletes* who are neither *International-Level* nor *National-Level Athletes*, an *Anti-Doping Organization* may elect to: conduct limited *Testing* or no *Testing* at all; analyse *Samples* for less than the full menu of *Prohibited Substances*; require limited or no whereabouts information; or not require advance *TUE*s. However, if an Article 2.1, 2.3 or 2.5 anti-doping rule violation is committed by any *Athlete* over whom an *Anti-Doping Organization* has elected to exercise its authority to test and who competes below the international or national level, then the *Consequences* set forth in the *Code* must be applied. For purposes of Article 2.8 and Article 2.9 and for purposes of anti-doping information and *Education*, any *Person* who participates in sport under the authority of any *Signatory*, government, or other sports organization accepting the *Code* is an *Athlete*.⁷⁵

⁷⁵ [Comment to Athlete: Individuals who participate in sport may fall in one of five categories: 1) International-Level Athlete, 2) National-Level Athlete, 3) individuals who are not International- or National-Level Athletes but over whom the International Federation or National Anti-Doping Organization has chosen to exercise authority, 4) Recreational Athlete, and 5) individuals over whom no International Federation or National Anti-Doping Organization has, or has chosen to, exercise authority. All International- and National-Level Athletes are subject to the anti-doping rules of the Code, with the precise definitions of international and national level sport to be set forth in the anti-doping rules of the International Federations and National Anti-Doping Organizations.]

Athlete Biological Passport: The program and methods of gathering and collating data as described in the *International Standard for Testing and Investigations* and *International Standard for Laboratories*.

Athlete Support Personnel: Any coach, trainer, manager, agent, team staff, official, medical, paramedical personnel, parent or any other *Person* working with, treating or assisting an *Athlete* participating in or preparing for sports *Competition*.

Attempt: Purposely engaging in conduct that constitutes a substantial step in a course of conduct planned to culminate in the commission of an anti-doping rule violation. Provided, however, there shall be no anti-doping rule violation based solely on an *Attempt* to commit a violation if the *Person* renounces the *Attempt* prior to it being discovered by a third party not involved in the *Attempt*.

Atypical Finding: A report from a WADA-accredited laboratory or other WADA-approved laboratory which requires further investigation as provided by the *International Standard for Laboratories* or related *Technical Documents* prior to the determination of an *Adverse Analytical Finding*.

Atypical Passport Finding: A report described as an *Atypical Passport Finding* as described in the applicable *International Standards*.

CAS: The Court of Arbitration for Sport.

Code: The World Anti-Doping Code.

Competition: A single race, match, game or singular sport contest. For example, a basketball game or the finals of the Olympic 100-meter race in athletics. For stage races and other sport contests where prizes are awarded on a daily or other interim basis the distinction between a *Competition* and an *Event* will be as provided in the rules of the UIM.

Consequences of Anti-Doping Rule Violations (“*Consequences*”): An *Athlete's* or other *Person's* violation of an anti-doping rule may result in one or more of the following: (a) *Disqualification* means the *Athlete's* results in a particular *Competition* or *Event* are invalidated, with all resulting *Consequences* including forfeiture of any medals, points and prizes; (b) *Ineligibility* means the *Athlete* or other *Person* is barred on account of an anti-doping rule violation for a specified period of time from participating in any *Competition* or other activity or funding as provided in Article 10.14; (c) *Provisional Suspension* means the *Athlete* or other *Person* is barred temporarily from participating in any *Competition* or activity prior to the final decision at a hearing conducted under Article 8; (d) *Financial Consequences* means a financial sanction imposed for an anti-doping rule violation or to recover costs associated with an anti-doping rule violation; and (e) *Public Disclosure* means the dissemination or distribution of information to the general public or *Persons* beyond those *Persons* entitled to earlier notification in accordance with Article 14. .

Contaminated Product: A product that contains a *Prohibited Substance* that is not disclosed on the product label or in information available in a reasonable Internet search.

Decision Limit: The value of the result for a threshold substance in a *Sample*, above which an *Adverse Analytical Finding* shall be reported, as defined in the *International Standard for Laboratories*.

Delegated Third Party: Any *Person* to which the UIM delegates any aspect of *Doping Control* or anti-doping *Education* programs including, but not limited to, third parties or other *Anti-Doping Organizations* that conduct *Sample* collection or other *Doping Control* services or anti-doping *Educational* programs for the UIM, or individuals serving as independent contractors who perform *Doping Control* services for the UIM (e.g., non-employee *Doping Control* officers or chaperones). This definition does not include CAS.

Disqualification: See *Consequences of Anti-Doping Rule Violations* above.

Doping Control: All steps and processes from test distribution planning through to ultimate disposition of any appeal and the enforcement of *Consequences*, including all steps and processes in between, including but not limited to *Testing*, investigations, whereabouts, *TUEs*, *Sample* collection and handling, laboratory analysis, *Results Management*, and investigations or proceedings relating to violations of Article 10.14 (Status During *Ineligibility* or *Provisional Suspension*).

Education: The process of learning to instill values and develop behaviors that foster and protect the spirit of sport, and to prevent intentional and unintentional doping.

Event: A series of individual *Competitions* conducted together under one ruling body (e.g., the Olympic Games, World Championships of an International Federation, or Pan American Games).

Event Period: The time between the beginning and end of an *Event*, as established by the ruling body of the *Event* (e.g. also specified in the *Advance Programme*).

Event Venues: Those venues so designated by the ruling body for the *Event*.

Fault: *Fault* is any breach of duty or any lack of care appropriate to a particular situation. Factors to be taken into consideration in assessing an *Athlete's* or other *Person's* degree of *Fault* include, for example, the *Athlete's* or other *Person's* experience, whether the *Athlete* or other *Person* is a *Protected Person*, special considerations such as impairment, the degree of risk that should have been perceived by the *Athlete* and the level of care and investigation exercised by the *Athlete* in relation to what should have been the perceived level of risk. In assessing the *Athlete's* or other *Person's* degree of *Fault*, the circumstances considered must be specific and relevant to explain the *Athlete's* or other *Person's* departure from the expected standard of behavior. Thus, for example, the fact that an *Athlete* would lose the opportunity to earn large sums of money during a period of *Ineligibility*, or the fact that the *Athlete* only has a short time left in a career, or the timing of the sporting calendar, would not be relevant factors to be considered in reducing the period of *Ineligibility* under Article 10.6.1 or 10.6.2.⁷⁶

Financial Consequences: See *Consequences of Anti-Doping Rule Violations* above.

In-Competition: The period commencing at 11:59 p.m. on the day before a *Competition* in which the *Athlete* is scheduled to participate through the end of such *Competition* and the *Sample* collection process related to such *Competition*.

Independent Observer Program: A team of observers and/or auditors, under the supervision of WADA, who observe and provide guidance on the *Doping Control* process prior to or during certain *Events* and report on their observations as part of WADA's compliance monitoring program.

Individual Sport: Any sport that is not a *Team Sport*.

Ineligibility: See *Consequences of Anti-Doping Rule Violations* above.

Institutional Independence: Hearing panels on appeal shall be fully independent institutionally from the *Anti-Doping Organization* responsible for *Results Management*. They must therefore not in any way be administered by, connected or subject to the *Anti-Doping Organization* responsible for *Results Management*.

International Event: An *Event* or *Competition* where the International Olympic Committee, the International Paralympic Committee, an International Federation, a *Major Event Organization*, or another international sport organization is the ruling body for the *Event* or appoints the technical officials for the *Event*.

International-Level Athlete: *Athletes* who compete in sport at the international level, as defined by each International Federation, consistent with the *International Standard for Testing and Investigations*. For the sport of powerboating which includes Aquabike and Motosurfs disciplines, *International-Level Athletes* are defined as set out in the Scope section of the Introduction to these Anti-Doping Rules.⁷⁷

International Standard: A standard adopted by WADA in support of the *Code*. Compliance with an *International Standard* (as opposed to another alternative standard, practice or procedure) shall be sufficient to conclude that the procedures addressed by the *International Standard* were performed properly. *International Standards* shall include any *Technical Documents* issued pursuant to the *International Standard*.

Major Event Organizations: The continental associations of *National Olympic Committees* and other international multi-sport organizations that function as the ruling body for any continental, regional or other *International Event*.

⁷⁶ [Comment to *Fault*: The criteria for assessing an *Athlete's* degree of *Fault* is the same under all Articles where *Fault* is to be considered. However, under Article 10.6.2, no reduction of sanction is appropriate unless, when the degree of *Fault* is assessed, the conclusion is that No Significant *Fault* or Negligence on the part of the *Athlete* or other *Person* was involved.]

⁷⁷ [Comment to *International-Level Athlete*: Consistent with the *International Standard for Testing and Investigations*, the UIM is free to determine the criteria it will use to classify *Athletes* as *International-Level Athletes*, e.g., by ranking, by participation in particular *International Events*, by type of license, etc. However, it must publish those criteria in clear and concise form, so that *Athletes* are able to ascertain quickly and easily when they will become classified as *International-Level Athletes*. For example, if the criteria include participation in certain *International Events*, then the *International Federation* must publish a list of those *International Events*.]

Marker: A compound, group of compounds or biological variable(s) that indicates the *Use of a Prohibited Substance or Prohibited Method*.

Metabolite: Any substance produced by a biotransformation process.

Minimum Reporting Level: The estimated concentration of a *Prohibited Substance* or its *Metabolite(s)* or *Marker(s)* in a *Sample* below which WADA-accredited laboratories should not report that *Sample* as an *Adverse Analytical Finding*.

Minor: A natural *Person* who has not reached the age of eighteen (18) years.

National Anti-Doping Organization: The entity(ies) designated by each country as possessing the primary authority and responsibility to adopt and implement anti-doping rules, direct the collection of *Samples*, the management of test results, and the conduct of hearings at the national level. If this designation has not been made by the competent public authority(ies), the entity shall be the country's *National Olympic Committee* or its designee.

National Event: A sport *Event* or *Competition* involving *International-* or *National-Level Athletes* that is not an *International Event*.

National Authority: A national or regional entity which is a member of or is recognized by the UIM as the entity governing the UIM's sport in that nation or region.

National-Level Athlete: *Athletes* who compete in sport at the national level, as defined by each *National Anti-Doping Organization*, consistent with the *International Standard for Testing and Investigations*.

National Olympic Committee: The organization recognized by the International Olympic Committee. The term *National Olympic Committee* shall also include the National Sport Confederation in those countries where the National Sport Confederation assumes typical *National Olympic Committee* responsibilities in the anti-doping area.

No Fault or Negligence: The *Athlete* or other *Person's* establishing that he or she did not know or suspect, and could not reasonably have known or suspected even with the exercise of utmost caution, that he or she had *Used* or been administered the *Prohibited Substance* or *Prohibited Method* or otherwise violated an anti-doping rule. Except in the case of a *Protected Person* or *Recreational Athlete*, for any violation of Article 2.1, the *Athlete* must also establish how the *Prohibited Substance* entered the *Athlete's* system.

No Significant Fault or Negligence: The *Athlete* or other *Person's* establishing that any *Fault* or *Negligence*, when viewed in the totality of the circumstances and taking into account the criteria for *No Fault* or *Negligence*, was not significant in relationship to the anti-doping rule violation. Except in the case of a *Protected Person* or *Recreational Athlete*, for any violation of Article 2.1, the *Athlete* must also establish how the *Prohibited Substance* entered the *Athlete's* system.

Operational Independence: This means that (1) board members, staff members, commission members, consultants and officials of the *Anti-Doping Organization* with responsibility for *Results Management* or its affiliates (e.g., member federation or confederation), as well as any *Person* involved in the investigation and pre-adjudication of the matter cannot be appointed as members and/or clerks (to the extent that such clerk is involved in the deliberation process and/or drafting of any decision) of hearing panels of that *Anti-Doping Organization* with responsibility for *Results Management* and (2) hearing panels shall be in a position to conduct the hearing and decision-making process without interference from the *Anti-Doping Organization* or any third party. The objective is to ensure that members of the hearing panel or individuals otherwise involved in the decision of the hearing panel, are not involved in the investigation of, or decisions to proceed with, the case.

Out-of-Competition: Any period which is not *In-Competition*.

Participant: Any *Athlete* or *Athlete Support Person*.

Person: A natural *Person* or an organization or other entity.

Possession: The actual, physical *Possession*, or the constructive *Possession* (which shall be found only if the *Person* has exclusive control or intends to exercise control over the *Prohibited Substance* or *Prohibited Method* or the premises in which a *Prohibited Substance* or *Prohibited Method* exists); provided, however, that if the *Person* does not have exclusive control over the *Prohibited Substance* or *Prohibited Method* or the premises in which a *Prohibited Substance* or *Prohibited Method* exists, constructive *Possession* shall only be found if the *Person* knew about the presence of the *Prohibited Substance* or *Prohibited Method* and intended to exercise control over it.

Provided, however, there shall be no anti-doping rule violation based solely on *Possession* if, prior to receiving notification of any kind that the *Person* has committed an anti-doping rule violation, the *Person* has taken concrete action demonstrating that the *Person* never intended to have *Possession* and has renounced *Possession* by explicitly declaring it to an *Anti-Doping Organization*. Notwithstanding anything to the contrary in this definition, the purchase (including by any electronic or other means) of a *Prohibited Substance* or *Prohibited Method* constitutes *Possession* by the *Person* who makes the purchase.⁷⁸

Prohibited List: The List identifying the *Prohibited Substances* and *Prohibited Methods*.

Prohibited Method: Any method so described on the *Prohibited List*.

Prohibited Substance: Any substance, or class of substances, so described on the *Prohibited List*.

Protected Person: An *Athlete* or other natural *Person* who at the time of the anti-doping rule violation: (i) has not reached the age of sixteen (16) years; (ii) has not reached the age of eighteen (18) years and is not included in any *Registered Testing Pool* and has never competed in any *International Event* in an open category; or (iii) for reasons other than age has been determined to lack legal capacity under applicable national legislation.⁷⁹

Provisional Hearing: For purposes of Article 7.4.3, an expedited abbreviated hearing occurring prior to a hearing under Article 8 that provides the *Athlete* with notice and an opportunity to be heard in either written or oral form.⁸⁰

Provisional Suspension: See *Consequences of Anti-Doping Rule Violations* above.

Publicly Disclose: See *Consequences of Anti-Doping Rule Violations* above.

Recreational Athlete: A natural *Person* who is so defined by the relevant *National Anti-Doping Organization*; provided, however, the term shall not include any *Person* who, within the five (5) years prior to committing any anti-doping rule violation, has been an *International-Level Athlete* (as defined by each International Federation consistent with the *International Standard for Testing and Investigations*) or *National-Level Athlete* (as defined by each *National Anti-Doping Organization* consistent with the *International Standard for Testing and Investigations*), has represented any country in an *International Event* in an open category or has been included within any *Registered Testing Pool* or other whereabouts information pool maintained by any International Federation or *National Anti-Doping Organization*.⁸¹

Regional Anti-Doping Organization: A regional entity designated by member countries to coordinate and manage delegated areas of their national anti-doping programs, which may include the adoption and implementation of anti-doping rules, the planning and collection of *Samples*, the management of results, the review of *TUEs*, the conduct of hearings, and the conduct of *Educational* programs at a regional level.

Registered Testing Pool: The pool of highest-priority *Athletes* established separately at the international level by International Federations and at the national level by *National Anti-Doping Organizations*, who are subject to focused *In-Competition* and *Out-of-Competition Testing* as part of that International Federation's or *National Anti-Doping Organization's* test distribution plan and therefore are required to provide whereabouts information as provided in Article 5.5 and the *International Standard for Testing and Investigations*.

Results Management: The process encompassing the timeframe between notification as per Article 5 of the *International Standard for Results Management*, or in certain cases (e.g., *Atypical Finding*, *Athlete Biological*

⁷⁸ [Comment to *Possession*: Under this definition, anabolic steroids found in an *Athlete's* car would constitute a violation unless the *Athlete* establishes that someone else used the car; in that event, the *UIM* must establish that, even though the *Athlete* did not have exclusive control over the car, the *Athlete* knew about the anabolic steroids and intended to have control over them. Similarly, in the example of anabolic steroids found in a home medicine cabinet under the joint control of an *Athlete* and spouse, the *UIM* must establish that the *Athlete* knew the anabolic steroids were in the cabinet and that the *Athlete* intended to exercise control over them. The act of purchasing a *Prohibited Substance* alone constitutes *Possession*, even where, for example, the product does not arrive, is received by someone else, or is sent to a third party address.]

⁷⁹ [Comment to *Protected Person*: The Code treats *Protected Persons* differently than other *Athletes* or *Persons* in certain circumstances based on the understanding that, below a certain age or intellectual capacity, an *Athlete* or other *Person* may not possess the mental capacity to understand and appreciate the prohibitions against conduct contained in the Code. This would include, for example, a Paralympic *Athlete* with a documented lack of legal capacity due to an intellectual impairment. The term "open category" is meant to exclude competition that is limited to junior or age group categories.]

⁸⁰ [Comment to *Provisional Hearing*: A *Provisional Hearing* is only a preliminary proceeding which may not involve a full review of the facts of the case. Following a *Provisional Hearing*, the *Athlete* remains entitled to a subsequent full hearing on the merits of the case. By contrast, an "expedited hearing", as that term is used in Article 7.4.3, is a full hearing on the merits conducted on an expedited time schedule.]

⁸¹ [Comment to *Recreational Athlete*: The term "open category" is meant to exclude competition that is limited to junior or age group categories.]

Passport, whereabouts failure), such pre-notification steps expressly provided for in Article 5 of the *International Standard for Results Management*, through the charge until the final resolution of the matter, including the end of the hearing process at first instance or on appeal (if an appeal was lodged).

Sample or Specimen: Any biological material collected for the purposes of *Doping Control*.⁸²

Signatories: Those entities accepting the *Code* and agreeing to implement the *Code*, as provided in Article 23 of the *Code*.

Specified Method: See Article 4.2.2.

Specified Substance: See Article 4.2.2.

Strict Liability: The rule which provides that under Article 2.1 and Article 2.2, it is not necessary that intent, *Fault*, *Negligence*, or knowing *Use* on the *Athlete's* part be demonstrated by the *Anti-Doping Organization* in order to establish an anti-doping rule violation.

Substance of Abuse: See Article 4.2.3.

Substantial Assistance: For purposes of Article 10.7.1, a *Person* providing *Substantial Assistance* must: (1) fully disclose in a signed written statement or recorded interview all information he or she possesses in relation to anti-doping rule violations or other proceeding described in Article 10.7.1.1, and (2) fully cooperate with the investigation and adjudication of any case or matter related to that information, including, for example, presenting testimony at a hearing if requested to do so by an *Anti-Doping Organization* or hearing panel. Further, the information provided must be credible and must comprise an important part of any case or proceeding which is initiated or, if no case or proceeding is initiated, must have provided a sufficient basis on which a case or proceeding could have been brought.

Tampering: Intentional conduct which subverts the *Doping Control* process but which would not otherwise be included in the definition of *Prohibited Methods*. *Tampering* shall include, without limitation, offering or accepting a bribe to perform or fail to perform an act, preventing the collection of a *Sample*, affecting or making impossible the analysis of a *Sample*, falsifying documents submitted to an *Anti-Doping Organization* or *TUE* committee or hearing panel, procuring false testimony from witnesses, committing any other fraudulent act upon the *Anti-Doping Organization* or hearing body to affect *Results Management* or the imposition of *Consequences*, and any other similar intentional interference or *Attempted* interference with any aspect of *Doping Control*.⁸³

Target Testing: Selection of specific *Athletes* for *Testing* based on criteria set forth in the *International Standard for Testing and Investigations*.

Team Sport: A sport in which the substitution of players is permitted during a *Competition*.

Technical Document: A document adopted and published by *WADA* from time to time containing mandatory technical requirements on specific anti-doping topics as set forth in an *International Standard*.

Testing: The parts of the *Doping Control* process involving test distribution planning, *Sample* collection, *Sample* handling, and *Sample* transport to the laboratory.

Testing Pool: The tier below the *Registered Testing Pool* which includes *Athletes* from whom some whereabouts information is required in order to locate and *Test* the *Athlete Out-of-Competition*.

Therapeutic Use Exemption (TUE): A *Therapeutic Use Exemption* allows an *Athlete* with a medical condition to *Use* a *Prohibited Substance* or *Prohibited Method*, but only if the conditions set out in Article 4.4 and the *International Standard for Therapeutic Use Exemptions* are met.

⁸² [Comment to *Sample or Specimen*: It has sometimes been claimed that the collection of blood *Samples* violates the tenets of certain religious or cultural groups. It has been determined that there is no basis for any such claim.]

⁸³ [Comment to *Tampering*: For example, this Article would prohibit altering identification numbers on a *Doping Control* form during *Testing*, breaking the *B* bottle at the time of *B* *Sample* analysis, altering a *Sample* by the addition of a foreign substance, or intimidating or attempting to intimidate a potential witness or a witness who has provided testimony or information in the *Doping Control* process. *Tampering* includes misconduct which occurs during the *Results Management* and hearing process. See Article 10.9.3.3. However, actions taken as part of a *Person's* legitimate defense to an anti-doping rule violation charge shall not be considered *Tampering*. Offensive conduct towards a *Doping Control* official or other *Person* involved in *Doping Control* which does not otherwise constitute *Tampering* shall be addressed in the disciplinary rules of sport organizations.]

Trafficking: Selling, giving, transporting, sending, delivering or distributing (or *Possessing* for any such purpose) a *Prohibited Substance* or *Prohibited Method* (either physically or by any electronic or other means) by an *Athlete*, *Athlete Support Person* or any other *Person* subject to the authority of an *Anti-Doping Organization* to any third party; provided, however, this definition shall not include the actions of bona fide medical personnel involving a *Prohibited Substance* Used for genuine and legal therapeutic purposes or other acceptable justification, and shall not include actions involving *Prohibited Substances* which are not prohibited in *Out-of-Competition Testing* unless the circumstances as a whole demonstrate such *Prohibited Substances* are not intended for genuine and legal therapeutic purposes or are intended to enhance sport performance.

UNESCO Convention: The International Convention against Doping in Sport adopted by the 33rd session of the UNESCO General Conference on 19 October 2005 including any and all amendments adopted by the States Parties to the Convention and the Conference of Parties to the International Convention against Doping in Sport.

Use: The utilization, application, ingestion, injection or consumption by any means whatsoever of any *Prohibited Substance* or *Prohibited Method*.

WADA: The World Anti-Doping Agency.

Without Prejudice Agreement. For purposes of Articles 10.7.1.1 and 10.8.2, a written agreement between an *Anti-Doping Organization* and an *Athlete* or other *Person* that allows the *Athlete* or other *Person* to provide information to the *Anti-Doping Organization* in a defined time-limited setting with the understanding that, if an agreement for *Substantial Assistance* or a case resolution agreement is not finalized, the information provided by the *Athlete* or other *Person* in this particular setting may not be used by the *Anti-Doping Organization* against the *Athlete* or other *Person* in any *Results Management* proceeding under the *Code*, and that the information provided by the *Anti-Doping Organization* in this particular setting may not be used by the *Athlete* or other *Person* against the *Anti-Doping Organization* in any *Results Management* proceeding under the *Code*. Such an agreement shall not preclude the *Anti-Doping Organization*, *Athlete* or other *Person* from using any information or evidence gathered from any source other than during the specific time-limited setting described in the agreement.



ENVIRONMENTAL CODE 2024



The UIM Environmental Code
has been acknowledged by RINA and allowed the UIM to be nominated
“2011 Green association”

TABLE OF CONTENTS

ENVIRONMENTAL CODE	246
TABLE OF CONTENTS	247
2. UIM ENVIRONMENTAL WORKING GROUP (EWG)	249
3. ENVIRONMENTAL STEWARD	250
4. UIM ENVIRONMENTAL DELEGATE	250
5. Noise	251
6. FUEL	252
7. PROTECTION OF GROUND AND WATER	252
8. CLEANING OF POWERBOATS	252
9. ACTION TO BE TAKEN BY DRIVERS / PARTICIPANTS	252
10. REQUIREMENTS TO ENCOURAGE ENVIRONMENTAL BEHAVIOUR BY THE SPECTATORS 253	
11. ACTION TO BE TAKEN BY INTERNATIONAL ORGANIZERS.....	253
12. RECOMMENDATIONS TO ALL SEA/LAKE/RIVER USERS	256
13. UIM ENVIRONMENTAL AWARD	256
14. UIM TRIANNUAL WORLD CIRCUMNAVIGATION RACE.....	256
15. GREEN LOGO	256

1. GENERAL PRINCIPLES

1. DEFINITION

Powerboat activities fall into three main categories: competition, recreation and transport. This code includes competitive activities for members running the UIM racing classes included the UIM rulebooks for offshore, circuit, pleasure navigation and aqua bike. The code is a working document until fully adopted by the UIM General Assembly.

1.2

Competitive powerboat racing events are a major constituent of the international and national sporting calendars, attracting an increasing audience and producing significant economic effects. It is a sport which, like most other sports, and human activities in general, creates an impact on the environment.

1.3

Power boating activities in general, as a means of transport or for recreation, continues to increase, and therefore must also be looked at from an environmental point of view. The UIM will do its best to transfer best practices from competitive power boating to these other areas.

1.4

The UIM considers it to be of major importance to develop a coherent environmental policy, taking into account the legislative and regulatory requirements of each country.

1.5

The UIM will seek to establish at all times the highest environmental standards during the organization of powerboat events at all levels and will promote environmental consciousness among all powerboat racers. The UIM will do so in close co-operation with the National Authorities and all involved stakeholders.

1.6

The UIM environment policy, as defined in this Code, is based on mutual respect of the needs of the environment and of reasonable practices of powerboat sports and powerboat driving in general.

1.7

The UIM seeks close co-operation with international authorities and organizations in order to ensure that there are sufficient facilities for powerboat activities in environmentally acceptable conditions and encourages its member nations to do so at national, regional and local level.

1.8

All national federations affiliated to the UIM shall do their best efforts in order to give proper prominence to environmental matters and to the principles of the UIM Environmental Code.

1.9

According to the above general principles, this Code prescribes regulations and recommendations to improve the relationship between Power boating competitions and the environment.

These regulations and recommendations refer in particular to:

- a) Climate emissions in cooperation with guidelines given from the UNEP and minimize to reach zero emissions in the future.
- b) Noise, fuel and protection of the water
- c) Behaviour of the spectators, organizers, officers and race participants in order to maintain the highest possible standards worldwide

1.10

The UIM encourage all national authorities to issue guidelines in line with the above and taking into considerations o regional and national legislations.

1.11

The non respect of a requirement of the UIM Environmental Code by an organizer or a racer or the person responsible for his/her racing team is liable to a fine, a disqualification from the event or a suspension. Moreover, the participant/driver/pilot may be liable for the damages caused by his/her non-respect of the environmental provisions.

2 UIM ENVIRONMENTAL WORKING GROUP (EWG)

2.1 ROLE AND RESPONSIBILITIES

Role

The Environmental Group role is to advise the UIM on what policy should be adopted in terms of environmental protection, alternative energies and support for sustainable development and, through its members, support the UIM programs and activities in this field.

Responsibilities

- Raise awareness on environment, alternative energies and sustainable development among UIM National Authorities and UIM stakeholders
- Disseminate knowledge and ensure know-how transfer in the above areas
- Promote environmental responsibility in the planning and staging of UIM events
- Ensure compliance of UIM affiliated members with the Environmental Code
- Promote the creation of an Environmental Working Group within National Federations
- Organize environmental seminars and establish a high profile network of correspondents
- Prepare an annual environmental report
- Presentation of the EWG work and findings at the UIM Council and General Assembly
- Advise the national environmental working groups on how to tackle environmental issues

- Liaise with external institutions such as public authorities, environmental organizations and other sporting bodies

3. ENVIRONMENTAL STEWARD

3.1 ROLE AND RESPONSIBILITIES

Role

At the UIM titled events there should be an official called the Environmental Steward who shall deal only with environmental aspects and who must have successfully completed a seminar organized by the UIM Environmental Working Group (hereafter EWG).

Responsibilities

- Ensure that the UIM Environmental Code is respected.
- Have access to all information concerning the event, and must be able to give prior, during and after the event, recommendations to the OOD on all aspects of the event which may have potential environmental consequences.
- Draw up in an appropriate manner a report on the basis of a checklist and send it to the UIM Secretariat. A copy should also be handed to the OOD and the UIM Environmental Delegate if present at the event. In case of a first non-respect of this point, the Environmental Steward will receive a warning from the UIM or its national federation. In case of a second offence, the UIM may pronounce against the Environmental Steward a suspension of up to 12 months.
- Instruct officials during national seminars for the various disciplines, as well as for racers and organizers.
- In case of non-respect or violation of the provisions mentioned in the present Code, he/she must immediately first inform the OOD.

4. UIM ENVIRONMENTAL DELEGATE

4.1 ROLE AND RESPONSIBILITIES

Role

The UIM Environmental Delegate is a member of and is nominated by the EWG. There is a need to find the premises for the Environmental Delegate to be able to operate. The UIM Commissioner will handle the environmental observations on title championships and include the observations in their report.

Responsibilities

- Observe and verify the application of the Environmental Code.
- Inform the OOD of any violation of the Environmental Code in order to pronounce sanctions relative to the infraction.
- Identify areas of “good practice” and make recommendations or proposals of modifications of the Environmental Code.
- Perform inspections of the racecourse and its facilities at any time before, during or after the event.
- Prepare a report summing up all important aspects of the event that relate to the environment.
- Any serious failure of the Environmental Steward towards the obligations and due diligence mentioned in article 2 of the present Code noticed by the UIM Environmental Delegate will be examined and, in case of need, sanctioned by the EWG with withdrawal of the Environmental Steward’s license for a period of up to 12 months.

An educational program is mandatory for the UIM environmental delegates.

5. NOISE

5.1 INTRODUCTION

Concerns regarding noise at powerboat events are not limited to the machines themselves. In addition to the expected engine noise, organizers and environmental stewards must be aware of the magnitude of sound from public address systems, crowds and other sources associated with an event. Minimizing excessive noise associated with powerboat activity and taking public reaction to noise in consideration is the responsibility of all concerned: drivers, clubs, organizers and officials.

5.2 NOISE OF POWERBOATS

Sound is a measurable phenomenon created when a source, such as a powerboat engine, causes the air to vibrate. In contrast, noise is an individual interpretation of the impact of that sound. A sound enjoyed by one may be annoying or even harmful to another. Powerboats with high sound levels are almost always considered noisy. The Environmental Steward must understand the difference between the two and how sound is quantified. The decibel (dB) is the unit used to express sound pressure levels and they are measured on several scales. Powerboat sound is tested on the "A" weighted scale and is expressed as dB (A). Sound pressure levels increase at a logarithmic rate (very quickly) while the human ear interprets that increase more slowly. As a consequence, each time the number of identical sound sources is doubled (as with many powerboats at the starting line), the sound pressure level measurement is increased by only 3 dB(A). Sound levels decrease as the distance from the source increases. A doubling of the distance from the source to the ear causes a loss of 6 dB (A). Temperature, geography, elevation, humidity and the frequency of the sound waves also contribute to the rate of energy loss. Such things as foliage, uneven ground and sea and large obstacles, such as walls, cars or embankments will reflect sound and affect sound levels in the immediate area.

The UIM recommends:

- a) To avoid all unnecessary running of engines.
- b) To reduce as much as possible the sound levels in all disciplines and ensure that all applicable regulations are strictly respected.
- c) The UIM shall always promote research on the question of sound level in relation to powerboat sports.
- d) The UIM will aim to set regulations stipulating the maximum permitted noise levels for each class. Noise levels should be set for the different classes in cooperation with the different commissions. When the limit has been set the regulations shall be monitored and sanctioned strictly.

5.3 SOUND LEVEL MEASUREMENTS

Environmental Stewards and event organizers should be familiar with local ordinances governing both event and powerboat sound levels. For details of specific sound levels for each discipline refer to the relevant rules. The UIM noise control method and sound levels are also recommended for national or club events.

5.4 PUBLIC ADDRESS SYSTEM

- a) Separate public-address systems for drivers' paddock and the public areas/enclosures are preferable and should never produce a higher sound than the hearing damage threshold level 83 dB(A) when measured in a public area and should also not exceed 3 dB(A) above the background and sea sound levels when measured at the nearest dwelling house.
- b) Position of loud speakers: slanted towards the ground and directed towards the centre of the course.
- c) Maintain sound level as low as possible. The whole system must be ready and tested 30 minutes before the start of the practice. The sound system often causes more annoyance outside the track area than the actual event. Make arrangements with the people in charge of the sound system to reduce the sound volume

between races/practice sessions.

6. FUEL

It is recommended that regular unleaded fuel, available at the service stations, or other cleaner fuels provided by the organizers, without additives, except oil for two stroke engines, is used.

The use of alternative energies such as bio fuels, hydrogen or electricity, as long as they are not more noxious for the environment, must be encouraged for all disciplines in conformity with the relevant technical regulations. For the purposes of protecting the environment, provisions regarding fuel storage mentioned in the relevant rules must be respected.

Transition implementation – When a Class has more than 50% of the entries using EPA engines at a World Championship then the non EPA engines are phased out.

For details, refer to the technical rules of the various sporting disciplines.

7. PROTECTION OF GROUND AND WATER

- a) Measures must be taken to prevent leaks of fuel, oil, cleaning, degreasing, cooling and brake fluids, etc. into the ground and water or vapour into the air.
- b) Containers/facilities to recover rubbish, oils, chemicals, detergents, etc. must be provided.
- c) The use of an environmental mat, (or other effective device) protecting the ground and water, is compulsory to be used where servicing of machines is permitted by the organizer, amongst others in the paddock and repair areas. Any infraction of this rule will be reported to the OOD who will fine the driver/pilot responsible a maximum of USD 1000 or any other amount mentioned in the regulation or appendix of the discipline.
- d) Provision must be made for the treatment of spillage and the disposal of contaminated material by the organizers.
- e) It is strictly forbidden to empty onto the ground and water waste fluids from vehicles or boats located in the drivers' paddock and the campsite. Waste water may only be disposed of at the circuit a proper facility to this effect. Any infraction to this rule will be reported to the OOD who will fine the driver/pilot responsible a maximum of USD 500. Other sanctions may be pronounced by the OOD or the UIM Commissioner.
- f) Do not leave on the spot sustainable evidence of any event, club or boating activity.

7.1 ENVIRONMENTAL MAT

The Environmental Mat is compulsory for all disciplines. It must be composed of an absorbent part and an impermeable part. Its use will be compulsory everywhere where work on powerboats is allowed by the organizers.

8. CLEANING OF POWERBOATS

- a) Cleaning of engine and motor parts, where permitted by the regulations, must only be carried out at places with cleaning facilities.
- b) Only certified non toxic solvent, without the addition of chemical products (for example detergent), is permitted when cleaning the boats.
- c) The cleaning area must be built with a non-porous surface and a proper drain with an oil-divider to prevent pollution of the ground and water. Any infraction of this rule will be reported to the Officer of the Day (OOD) who will fine the driver/pilot responsible a maximum of USD 500. – or any other amount mentioned in the regulation or appendix of the discipline.

9. ACTION TO BE TAKEN BY DRIVERS / PARTICIPANTS

- a) Each driver is responsible for the waste generated by his/her team during the event.
- b) Where organizers provide the necessary containers for waste they must be used as directed.
- c) Waste must be retained by the team until the approved facilities provided by organizers can be used.

- d) Where refuelling or servicing of a powerboat is being undertaken at events, driver/participants must provide and use an environment mat to protect the ground and water. This environmental mat must also be compulsory when an electrical generator or any other device with a thermal engine is used by the driver/pilot or the team. These mats must be removed by the driver/pilots/competitors after use.
- e) Any infringement by the participant or driver/pilot (who is responsible for his/her team) of the UIM regulations can result in a fine, disqualification from the event or suspension, and may also result in the participant or driver/pilot being liable for any costs of rectification.

10. REQUIREMENTS TO ENCOURAGE ENVIRONMENTAL BEHAVIOUR BY THE SPECTATORS

Visitors to a powerboat circuit, track, event or gathering can play an important role in keeping the environment clean and undamaged. Here are some suggestions:

- a) In co-operation with the local authorities, select the routes to and from circuits, tracks, etc., which will cause as little annoyance as possible for the surrounding areas.
- b) Provide clear signs to circuits, tracks and venues.
- c) Avoid parking on vulnerable places (verges, green lanes).
- d) Avoid parking in long grass.
- e) Promote the use of public transportation in publications and promotional releases i.e. web or other forums.
- f) Avoid too high concentrations of people in order to preserve vulnerable places i.e. wildlife and bird reservation.
- g) Provide sufficient sanitary facilities and safe cleaning and deposit systems.
- h) Inform the spectators about responsible behaviour on the site.
- i) Specify in contracts with catering firms a requirement to sell drinks and food packaged in recyclable, reusable or biodegradable material, and to provide and maintain sufficient waste containers. Promote cooperation with caterers that have high standards on ethical and ecological food.
- j) Manage the events in such a way that only footsteps remain on the soil.

11. ACTION TO BE TAKEN BY INTERNATIONAL ORGANIZERS

Promote environmental behaviour among all persons involved within the organization and promote environmentally friendly work within the secretariat and the administration to save paper and energy.

Venues creating participants more than 50 and/or spectators more 20 000, shall make a more comprehensive written environmental plan including the following points:

1. Use of resources (energy, chemicals and materials)
2. Impact on environment and climate emissions
3. Carbon offsetting all activities related to events from
4. Recycling and reduction of waste
5. Travelling and accommodation for spectators and guests
6. Birds, animals and wildlife
7. Visual environment

Any organizer of an event under the authority of the UIM is subject to its regulation and jurisdiction. Any clearly established infraction or inobservance of the prescriptions and obligations for the organizers are subject to the penalties laid down in the present Environmental Code or in other UIM disciplinary procedures.

Infringement of Article 11 will be reported to the UIM ExCO who can fine the organizer a minimum of USD 1000 or

any other amount mentioned in the regulation or appendix of the specific discipline.

11.1 ENVIRONMENTAL PROVISIONS

Make arrangements to prevent pollution of the ground and water in the drivers' dry/wet pits and surrounding areas. Look after the protection of verges along the access roads, parking, and fencing off (tape) vulnerable areas. The facilities for practice, racing, gatherings and the surroundings must be protected as much as possible from pollution and annoyance. Having regard to the expected number of spectators, provide and maintain sufficient and clean sanitation, with proper provisions for waste and water.

Measures must also be taken to prevent:

- a) Leakage of fuel, oil, cleaning, degreasing, cooling and brake fluids, etc. into the ground and water or vapour into the air.
- b) Waste from participants, their teams, spectators and selling points not being collected in waste-bins or containers and being left on the ground and water at the site.
- c) Sanitary facilities being connected improperly to the sewerage.
- d) Waste collected and removed in an illegal way.
- e) UIM sound levels for powerboats during practice or event being exceeded.
- f) Inordinate sound levels at tourist gatherings.
- g) The maximum number of events and/or practicing time being exceeded.

11.2 LOGBOOK / CHECK-LIST

It is important for every motor sport event organizer to maintain a "logbook" in which is written all activities and measures that have been taken, what meetings have taken place and with whom, what permissions have been sought and those that have been granted relative to the use and maintenance of the facilities for powerboat sport or other event. If permission is only given for use of the facilities for a certain period of time, the exact time when it is in use must also be noted. Together with the logbook it is useful to use a checklist for the management of the facilities, to stimulate an environment friendly behaviour by the spectators and an environment friendly use of the facilities during events. This checklist must include at least the following points:

- a) An assessment of the environmental impact of the event on the circuit and its surroundings, having regard to the number of competitors and the expected number of spectators.
- b) Cleaning area with high-pressure cleaners for powerboats.
- c) Distribution of waste bags to participants and their teams.
- d) Containers for used oil, cooling fluid or any other liquid.
- e) Containers for spectators' general litter.
- f) Sanitary facilities.
- g) Judicious positioning of loud speakers.
- h) Provision of adequate and appropriate direction signs to the event.
- i) Provision of containers or waste bags in the pits of the mechanics' area and collection of the contents during and after the event.

11.3 PUBLICITY/ADVERTISING

- a) The UIM suggest aggressive use of the Web and media instead of prints/posters on paper.
- b) Do not attach posters to trees, in country areas and/or protected urban sites nor in places and areas which are not appropriate.
- c) Place billboards only after having obtained permission from the owner of the property.
- d) Take local and governmental regulations into account when placing billboards.
- e) Do not distribute leaflets/pamphlets under windscreen wipers of cars, on powerboats, nor to spectators (do not allow others to do so during your event).

11.4 DRIVER PADDOCK / SERVICE AREAS / TIME CONTROL AREAS

- a) Present every participant on arrival with a rubbish bag and instructions.
- b) Provide sufficient containers for the rubbish bags and set recycling stations accessible to the public and participating teams.
- c) Ensure that there are enough containers with fixed funnels to collect used oil.
- d) Provide recognizable containers for oil filters and cleaning rags; collect separately.
- e) Provide and maintain sufficient and clean sanitation, with proper provisions for waste and water, for both men and women.
- f) If cleaning of powerboats is allowed, a special wash area designed to ensure the ground and water is not polluted must be provided in accordance with the rules of the discipline concerned.
- g) The use of an environmental mat is compulsory when a generator or any other device with a thermal engine is used.

11.5 AFTER THE EVENT

- a) Signposts, billboards and posters must be removed after the event.
- b) Waste left behind on the site and the surroundings must be cleaned up and removed as soon as possible.
- c) Clear away and dispose of any broken branches or shrubs.
- d) Clear away tape, buoys and rope/weights around the track.
- e) Arrange for separate removal of oil-containers, cleaning rags, oil filters and waste-containers.
- f) The infraction or inobservance by the organizer of obligations mentioned in the present Environmental Code are subject to sanctions laid down in this Code and can result in a fine or suspension of approval to organize UIM events. The organizer will also be liable for any costs of rectification.

11.6 GENERAL REGULATIONS FOR THE MANAGEMENT OF VENUES

- a) Keep up the maintenance of the venue and take care that it is kept clean and tidy at all times.
- b) Cordon off sensitive areas.
- c) Appoint a member of the Organizing Board to be in charge of all environmental aspects and maintain the environment logbook.
- d) Ensure proper disposal of waste from sanitary facilities.
- e) Take all necessary care when making changes/adjustments to the site and consult the appropriate authorities.
- f) When locating the starting areas, take acoustic impacts into account.
- g) Never use building waste, rubble, etc. for the construction of noise barriers, etc.
- h) In case of the use of materials from outside, have them checked by the appropriate authorities to ensure that they are not polluted.
- i) Following every event and at regular intervals, make an evaluation of the impact of the event on the environment; make a report of it in the logbook; and make recommendations to correct any shortcomings and errors.

12. RECOMMENDATIONS TO ALL SEA/LAKE/RIVER USERS

12.1 INTRODUCTION

We must voluntarily moderate and add a greater degree of responsibility to our natural desire for individual mobility. We should try to achieve results on the basis of freedom of thought and movement and exploit every opportunity to combine the pleasure of Powerboating more effectively with ecological and economic needs.

12.2 DRIVER CONDUCT

- a) Individual power boaters should develop driving habits to ensure full integration with other types of sea, lake and river users.
- b) Ride safely and avoid aggressive driving.
- c) Save petrol and reduce pollution by avoiding unnecessary idling of engines.
- d) Limit noise pollution
- e) Noise annoyance. Use exhaust system (towards/into water) which minimize noise and keep audio systems at a low level.
- f) Protect wildlife and its natural habitat
- g) Ensure that your used oil, batteries and other recyclable items are properly recycled or collected.
- h) Remember that our seas/lakes/ivers belong to the overall community.

13. UIM ENVIRONMENTAL AWARD

In order to encourage a greater awareness of environmental concerns, the UIM has created an Environmental Award to reward a significant contribution to the protection of the environment. This Award may be given each year according to the following rules:

- a) By "year", the EWG understands that the year taken into consideration to award the prize starts on 1 January and ends on 30 September. The candidatures must arrive at the UIM Secretariat by the 5 October at the latest.
- b) This distinction is granted for rewarding individuals, clubs, organizers, manufacturers or other organizations that have made a significant contribution or done something important to enhance environmental awareness in the field of Power boating
- c) Candidatures for the Environmental Award will be submitted to the UIM by October 5th at the latest. The EWG may also propose a candidate.
- d) The candidatures received will be examined by the UIM Environment Group prior to submitting them to the ExCo. The recipient can be invited to the UIM GA to receive his/her (their) distinction.
- e) These nominations should be submitted, along with a description of the occurrence qualifying for the Award, to the UIM Secretariat within the set deadline

14. UIM TRIANNUAL WORLD CIRCUMNAVIGATION RACE

Every three years the UIM may organize a world circumnavigation race. The race shall be performed on alternative energy and sustainability principles.

15. GREEN LOGO

The UIM have approved this Green Logo



The Rules and/or regulations set forth herein are designed to provide for the orderly conduct of competitive events and to establish minimum acceptable requirements for such events. These rules shall govern the condition of all UIM events. By participating in the events, all UIM members are deemed to have complied with these rules. No express or implied warranty of safety shall result from publications of, or compliance with these rules and/or regulations. They are intended as a guide for the conduct of the sport and are in no way a guarantee against injury or death to participants, spectators, or others.

The rules are published on the UIM Website: www.uim.sport

© (2024) Copyright by UIM - Union Internationale Motonautique. All rights reserved. No part of this document/publication may be reproduced, distributed, or transmitted in any form or by any means without the prior written consent of the UIM, except for the non-commercial use within the scope of authority of the UIM and its affiliated members.



UIM

uim@uim.sport